

Why Not Wye? (or, “Successful Monoing Of Your Low End”)

- **Splitting Signals**
- **Subwoofing in Mono**
- **Unbalanced Summing**
- **Balanced Summing**
- **Output Impedances**

Dennis Bohn
Rane Corporation

RaneNote 109
© 1991 Rane Corporation

Introduction

Wye-connectors (or “Y”-connectors, if you prefer) should never have been created.

Anything that can be hooked-up wrong, will be. You-know-who said that, and she was right. A wye-connector used to *split* a signal into two lines is being used properly; a wye-connector used to *mix* two signals into one is being abused and may even damage the equipment involved.

Here is the rule: Outputs are low impedance and must *only* be connected to high impedance *inputs*—never, never tie two outputs directly together—never. If you do, then each output tries to drive the very low impedance of the other, forcing both outputs into current-limit and possible damage. As a minimum, severe signal loss results.

Monoing Your Low End

One of the most common examples of tying two outputs together is in “monoing” the low end of multiway active crossover systems. This combined signal is then used to drive a sub-woofer system.

Since low frequencies below about 100 Hz have such long wavelengths (several feet), it is very difficult to tell where they are coming from (like some of your friends). They are just there—everywhere. Due to this phenomenon, a single sub-woofer system is a popular cost-effective way to add low frequency energy to small systems.

So the question arises as how best to do the monoing, or summing, of the two signals? It is done very easily by tying the two low frequency outputs of your crossovers together using the resistive networks described below. You do *not* do it with a wye-cord.

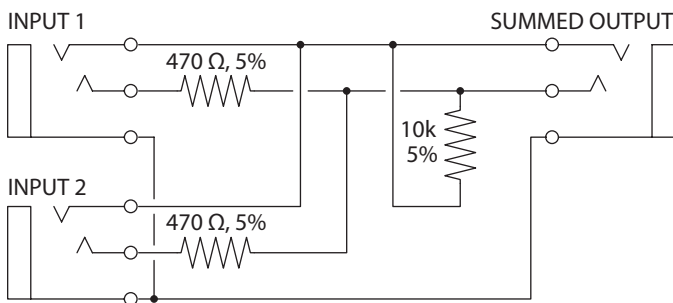

Figure 1. Unbalanced Summing Box

Summing Boxes Unbalanced Summing Box

Figure 1 shows the required network for sources with unbalanced outputs. Two resistors tie each input together to the junction of a third resistor, which connects to signal common. This is routed to the single output jack. The resistor values can vary about those shown over a wide range and not change things much. As designed, the input impedance is about 1 k Ω and the line driving output impedance is around 250 Ω . The output impedance is small enough that long lines may still be driven, even though this is a passive box. The input impedance is really quite low and requires 600 Ω line-driving capability from the crossover, but this should not create problems for modern active crossover units.

The rings are tied to each other, as are the sleeves; however, the rings and sleeves are not tied together. Floating the output in this manner makes the box compatible with either balanced or unbalanced systems. It also makes the box ambidextrous: It is now compatible with either unbalanced (mono, 1-wire) or balanced (stereo, 2-wire) ¼" cables. Using mono cables shorts the ring to the sleeve and the box acts as a normal unbalanced system; while using stereo cables takes full advantage of the floating benefits.

Stereo-to-Mono Summing Box

Figure 2 shows a network for combining a stereo input to a mono output. The connectors are either ¼" or 3.5mm jacks. The comments regarding values for Figure 1 apply equally here.

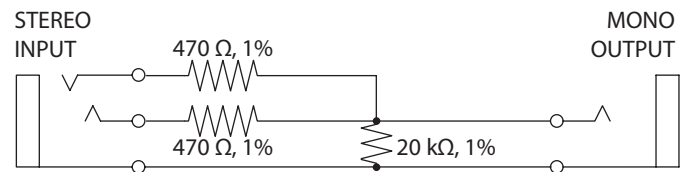

Figure 2. Stereo-to-Mono Box

Balanced Summing Boxes

Figures 3 and 4 show wiring and parts for creating a balanced summing box. The design is a natural extension of that appearing in Figure 1. Here both the tip (pin 2, positive) and the ring (pin 3, negative) tie together through the resistive networks shown. Use at least 1% matched resistors. Any mismatch between like-valued resistors degrades the common-mode rejection capability of the system.

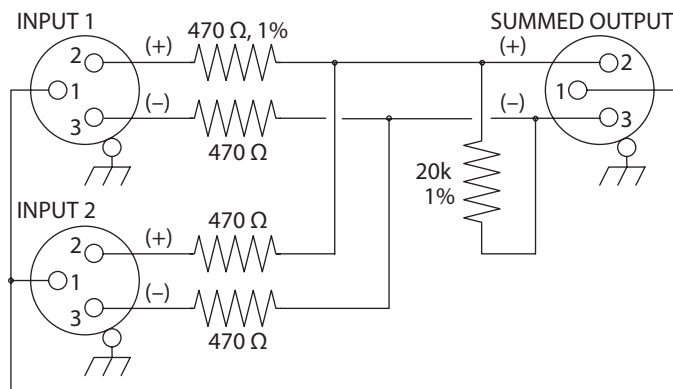

Figure 3. Balanced summing box using XLR connectors

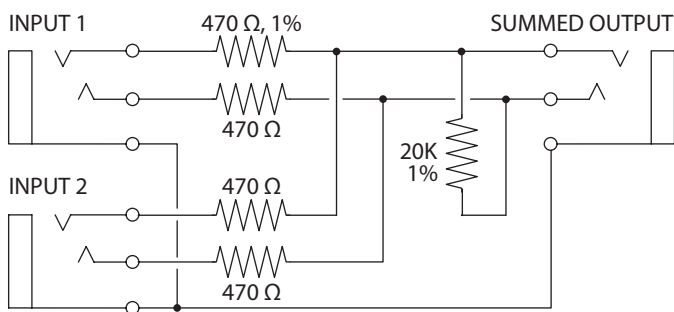

Figure 4. Balanced summing box using 1/4" TRS connectors

Termites in the Woodpile

Life is wonderful and then you stub your toe. The corner of the dresser lurking in the night of this Note has to do with applications where you want to sum two outputs together *and* you want to continue to use each of these outputs separately. If all you want to do is sum two outputs together and use *only* the summed results (the usual application), skip this section.

The problem arising from using all three outputs (the two original and the new summed output) is one of channel separation, or crosstalk. If the driving unit truly has zero output impedance, than channel separation is not degraded by using this summing box. However, when dealing with real-world units you deal with finite output impedances (ranging from a low of 47 Ω to a high of 600 Ω). Even a low output impedance of 47 Ω produces a startling channel separation spec of only 27 dB, i.e., the unwanted channel is only 27 dB below the desired signal. (Technical details: the unwanted channel, driving through the summing network, looks like 1011.3 Ω driving the 47 Ω output impedance of the desired channel, producing 27 dB of crosstalk.)

Now 27 dB isn't as bad as first imagined. To put this into perspective, remember that even the best phono cartridges have channel separation specs of about this same magnitude. So, stereo separation is maintained at about the same level as a home system.

For professional systems this may not be enough. If a trade-off is acceptable, things can be improved. If you scale all the resistors up by a factor of 10, then channel separation improves from 27 dB to 46 dB. As always though, this improvement is not free. The price is paid in reduced line driving capability. The box now has high output impedance, which prevents driving long lines. Driving a maximum of 3000 pF capacitance is the realistic limit. This amounts to only 60 feet of 50 pF/foot cable, a reasonable figure. So, if your system can stand a limitation of driving less than 60 feet (18 meters), scaling the resistors is an option for increased channel separation.

