

Interfacing AES3 & S/PDIF

- Initials, Acronyms & Standards
- AES3 (AES/EBU) & S/PDIF Differences
- AES-3id Variation
- Conversion Cautions
- Converting AES3, AES-3id & S/PDIF

Dennis Bohn
Rane Corporation

RaneNote 149
© 2001, 2014 Rane Corporation

Overview

Mainstream digital audio dates from the introduction of the compact disc in the early '80s, making it about twenty years old. Today two serial interfaces coexist: **AES3** (aka **AES/EBU**) for professional use and **S/PDIF** for consumer products. Simple low-cost passive conversion between them is possible – even easy – but it is also filled with cautions. The old rule that direct connection between AES/EBU and S/PDIF equipment is bad practice is relaxed today with new receiver chips tolerant to either interface. With that said, let's explore this tangled nest.

Initials, Acronyms & Standards

The professional digital audio interface known as AES/EBU is initialism for *Audio Engineering Society/European Broadcasting Union*, the two organizations that created the first two-channel digital audio serial interface standard in 1985. Issued as AES3-1985, it was subsequently revised & reissued, with the latest version (as of 2001) being **AES3-1992 (r1997) AES Recommended Practice for Digital Audio Engineering – Serial transmission format for two-channel linearly represented digital audio data**. It was also made an American National Standard, issued as **ANSI S4.40-1992**, and an international standard, issued as **IEC 60958-4**. The importance is that *all* of these documents cover the same serial interface, which is now correctly called the **AES3** interface. Ray A. Rayburn adds "*AES3 allows the use of transformer or transformerless interfaces, while the corresponding EBU standard requires the use of transformers. Therefore it has become a common shorthand to say AES/EBU when the interface is transformer coupled, and AES3 when it is not or if the interface type is unknown.*"

In the consumer universe we find the acronym **S/PDIF** (also seen without the slash as **SPDIF**) created from *Sony/Philips digital interface format*. This was also made an international standard and issued as **IEC 60958-3** (same number, different dash as the professional version), and it conforms with the EIAJ (*Electronic Industry Association Japan*) standard **CP-1201** (renumbered **CP-340**).

AES-3id-1995 AES information document for digital audio engineering – Transmission of AES3 formatted data by unbalanced coaxial cable is the same format as AES3 but instead of 110 Ω balanced line, it is a 75 Ω unbalanced line using BNC connectors and carried over the same coaxial interface as consumer S/PDIF. AES3id (*the hyphen is dropped for simplicity*) is a special AES3 subset for broadcast applications and long distance runs. (*For long distance high-frequency transmission, unbalanced coax is superior to balanced lines due to the high capacitance of shielded twisted-pair cable.*) Conversion between AES3 and AES3id is very similar to S/PDIF.

[**Note** AES3 is a professional (only) audio standard and S/PDIF is a consumer (only) audio standard, while IEC 60958 and EIAJ CO-1201 cover both consumer and professional definitions.]

[**Caution** Do not confuse S/PDIF with **SDIF** (no P); they are very different. SDIF, developed and used exclusively by Sony on early professional machines, is mono and not self-clocking, consequently requiring three cables for interconnection: two for the stereo channels and one for the synchronization clock.]

Differences Between AES3 and S/PDIF

This table summarizes the differences in the electrical characteristics of AES3 and S/PDIF interfaces:

	AES3 ¹	AES3 ⁶	AES3id ²	S/PDIF ³
Interface	Balanced	Balanced	Unbal	Unbal
Connector	XLR-3	CAT 5	BNC	RCA
Impedance	110 Ω	110 Ω	75 Ω	75 Ω
Output Level	2-7 V _{p-p}	2-7 V _{p-p}	1.0 V _{p-p}	0.5 V _{p-p}
Max Output	7 V _{p-p}	7 V _{p-p}	1.2 V _{p-p}	0.6 V _{p-p}
Max Current	64 mA	64 mA	1.6 mA	8 mA
Min Input ⁵	0.2 V	0.2 V	0.32 V	0.2 V
Cable	STP ⁴	CAT 5	Coax	Coax
Max Distance	100 m	400 m	1000 m	10 m

The table indicates a large difference between the minimum output level and the minimum input level (2 V vs. 0.2 V for AES3 for instance). The difference is accounted for by two factors: 1) Half the signal is lost due to the impedance matching required for high-speed transmission lines (*output impedance equals input impedance creating a 6 dB pad*); and 2) Signal loss driving long cables.

¹AES3-2003; ²AES-3id-2001; ³IEC 60958-3; ⁴Shielded twisted-pair; ⁵V_{min} for eye pattern T_{min} of 50% of T_{nom} (*eye pattern* is a measurement method for determining transmission quality.) ⁶ AES3-2003 (Annex D)

Conversion Caution

You can convert one electrical interface to another with just a few parts, but the protocol used in AES3 and S/PDIF is not exactly the same and that can cause problems. The basic data formats are identical, but there is a bit in the channel status frame that tells which is which, and assigns certain bits different meanings.

This sets the stage for incompatibilities. Many older units are sticklers about what's what in each bit, and even though a given signal faithfully complies with the standard, some equipment will still reject it. Fortunately, many units are flexible and tolerant so simple resistor or transformer converters work. But be warned that a converter that works fine with one unit is no guarantee it will work fine with all units.

Remember that even though the *audio data* is the same between AES3 and S/PDIF, they have different *subcode* formats. AES3 converted to 75 Ω coax is *not* S/PDIF, and S/PDIF converted to XLR balanced is *not* AES3. Nor is AES3id 75 Ω BNC the same as 75 Ω RCA S/PDIF – it may work, but it is not the same. They are still in their native format; just the transmission medium has changed. Going from S/PDIF to AES3 has a higher degree of success than the other way around. AES3 signals often are not recognized as valid by S/PDIF inputs. Whether they will work in your application depends on the equipment chosen.

Therefore the following passive circuits convert only the signal level and impedance, and not other protocol details (e.g., sample rate, consumer/professional status, nor correct any block errors in the data stream).

Examining the table reveals the difference in levels as the most troubling. The minor impedance mismatch is easily taken care of, but the levels and drive currents are another matter entirely for a passive converter. (*If you add power supplies to the converter then it becomes straightforward, but that is the subject of another Note and another day.*)

AES3 to AES3id or S/PDIF

IF (BIG if) you know that either the transmitter or the receiver is transformer coupled and the interconnect distance is short then a simple resistor divider will match the impedances and change the level as shown in Figure 1. This is the AES3id recommended network for creating a 12-dB pad (4:1 voltage divider) and converting the AES3 110 Ω balanced output impedance into 75 Ω for driving the AES3id input. Therefore an average output level of 4 volts will be reduced to 1 volt. Since this exceeds the max allowed for S/PDIF, use the values shown in parenthesis to create an 18-dB pad (8:1 voltage divider) producing 0.5 volt output for the same 4 volts input. (*Other average AES3 output voltages require different resistors – consult AES3id for value graph.*)

Transformers make the best passive impedance matchers, plus provide the benefits of ground isolation, high-frequency rejection, DC blocking and short-circuit protection. Impedance matching is easily handled by selection of the appro-

priate turns ratio (1.21:1 for 110 Ω to 75 Ω – *it's the square of the turns ratio for impedance*) and careful attention to winding details allow wideband high-frequency transformers (you need ~12.5 MHz). The best and safest converter includes the transformer.

If you are not sure about the transformer isolation of the equipment interfacing, use a store-bought impedance matching transformer that comes complete with connectors and a separate resistor voltage divider network as shown in Figure 2. This T-network is a 75 Ω :75 Ω bi-directional attenuator. The attenuation is a little less than that of Figure 1 for the same (*assumed*) 4-volt AES3 input because the transformer reduces the voltage level by a factor of 1.21:1 (down to 3.3 volts) as well as matching the impedances.

AES3id or S/PDIF to AES3

This conversion only requires impedance matching since the levels are smaller than AES3, but compatible. No satisfactory resistor-only network exists to convert between AES3id or S/PDIF and AES3 even though one appears in the AES3id document. While the network given matches the impedance, it does so with an attenuation of the input signal, running the risk of making it too small for the AES3 receiver, and it does not create the balanced 110 Ω lines that an AES3 receiver needs. Therefore it is recommended to use a transformer for this conversion as shown in Figure 4. Note that this adapter is identical to that shown in Figure 3, only driven backwards. Using the store-bought converter with a male-to-female adapter allows it to be fully bi-directional – or build your own using the recommended transformers. *BUT DO NOT FORGET that the levels coming out of an AES3 transmitter are too large for the typical AES3id or S/PDIF input so you must add the attenuator. Going the other way you do not need the attenuator since all AES3 receivers can handle the smallest in-spec AES3id or S/PDIF output signal as long as a minimum of 200 mV arrives.*

AES3id to S/PDIF & Vice-Versa

Since both formats use 75 Ω coaxial cable, connecting an AES3id output to an S/PDIF input is simple. All that is needed is to provide compatible hardware hook-up and a 6-dB pad (2:1 attenuator). As long as connecting distances are short, the simple T-network shown in Figure 5 does the job.

S/PDIF outputs may be connected directly to AES3id inputs – no adapter is required (but don't forget the formatting caveats mentioned above).

NOTE that even though the network is symmetrical and functions normally in either direction, it is to be used only to interface between an AES3id output and an S/PDIF input. If this adapter is used the other way around, to connect an S/PDIF output to an AES3id input, the attenuation may make the S/PDIF signal too small for the AES3id receiver to acquire.

Off-the-Shelf Sources

Retail Sources:

- Neutrik AES/EBU Impedance Transformers
<http://www.neutrik.us/en-us/accessories/aes-ebu-impedance-transformers/>
- C4 Audio Systems SA XM BF series
<http://www.proaudio.uk.com/dip/c4home.htm>
- RDL HR-UDC1 Universal Digital Audio Converter
<http://www.rdlnet.com/product.php?page=448>
- Henry Engineering Digimatch
<http://www.henryeng.com/hedigimatch.html>
- Hosa CDL-313 Digital Audio Interface
<http://hosatech.com/product/cdl-313/>
- Canare BCJ Adaptor
<http://www.canare.com/ProductItemDisplay.aspx?productItemID=15>

Alternatively, build the impedance matching transformer into the resistor network, as shown in Figure 3.

Component Sources:

- Scientific Conversion SC961-04 (SMT) (evaluation PCB available [good tech notes])
<http://www.scientificconversion.com/>
- Or Schott P/N 22523 (thru-hole)
<http://www.schottcorp.com/>

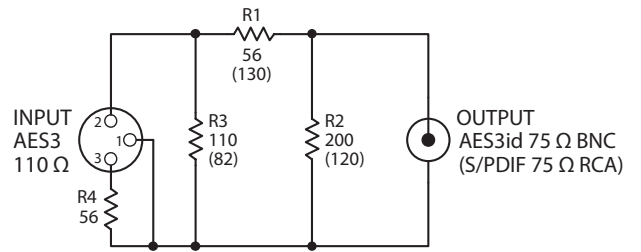
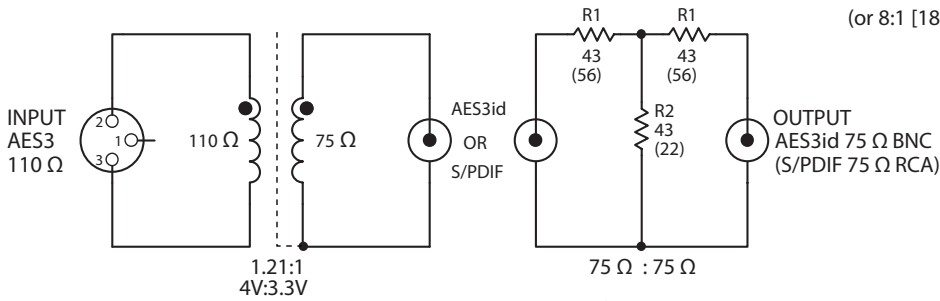

Fig. 1

AES3 to AES3id & S/PDIF Converter
 Resistor Impedance Matching Voltage Divider
 110 Ω to 75 Ω; 4:1 (12 dB) PAD
 AES3 4V out = AES3id 1V in
 (or 8:1 [18 dB] PAD; AES3 4Vout = S/PDIF 0.5V in)



a) Store-Bought Impedance Matching Transformer
 Attenuator
 11dB Pad for AES 3id 3.3Vin = 1Vout
 (17dB Pad for S/PDIF) (3.3Vin = 0.5Vout)

Fig. 2

AES3 to AES3id & S/PDIF Converter
 using separate transformer and voltage dividing network.

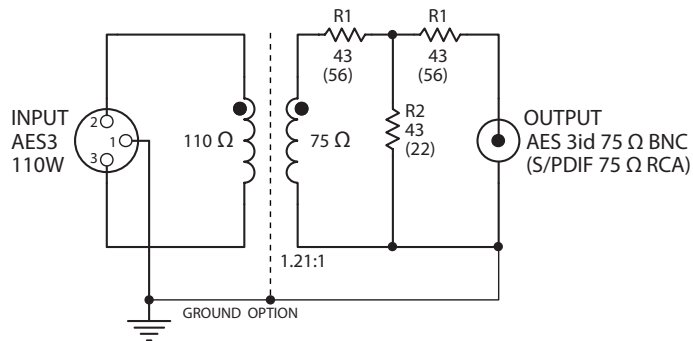

Fig. 3

AES3 to AES 3id & S/PDIF Converter
 Transformer Impedance Matching & Resistor Voltage Divider
 110 Ω to 75 Ω; 4:1 (12 dB) PAD
 AES3 4Vout = AES3id 1V in
 (AES3 4Vout = S/PDIF 0.5Vin)

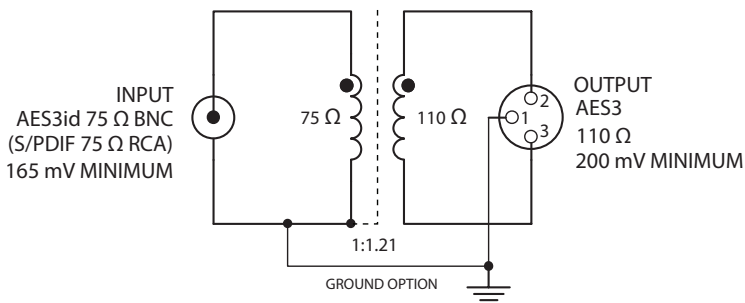

Fig. 4

AES3id or S/PDIF to AES3 Converter

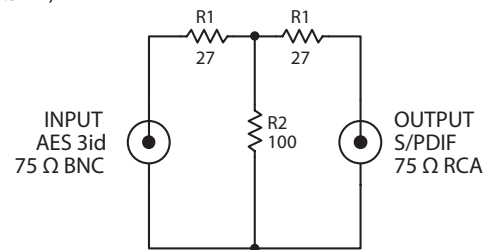

Fig. 5

AES3id to S/PDIF Converter
 75 Ω to 75 Ω 6 dB attenuator