



### Description

The TTM 52i Performance Mixer is a precision instrument designed for the serious DJ. Like the TTM 54i, “this ain’t no toy!” The TTM 52i features the same high quality components, reliability and performance as the Rane TTM 54i mixer with a reduced feature set (see the comparison chart on the last page of this Data Sheet.) The TTM 52i offers a more cost effective solution for DJs who demand the same quality and performance as the TTM 54i, but do not require the additional features.

The Rane Mojo Series maintains sonic and construction quality not found (until now) in this price range. Designed for the working musician...simple operation...reduced features...without compromise in audio quality or dependability.

### New “i” Features

- *Lexan® face plate insures sharp appearance for years to come*
- *Improved Transform (Phono/Line) switches*

### Unique Features

- A precision *Active Crossfader™* with continuously adjustable Contour and “Hamster” reversal controls, provides the lowest feed-through, lowest noise, and most responsive control in the industry, all with unprecedented reliability (see Fig. 1).
- Front panel “Hamster” reversal switch and *Active Program Faders*.
- Independent 18 dB / octave Rumble filters for *each* phono input.

### Other Features

- Two Phono and two Line inputs with high quality, long-life *clickless* transform selector switches.
- Balanced Mic input with Bass and Treble tone controls and independent Effects Loop.
- Balanced ¼" TRS and Unbalanced RCA Master outputs.
- Dual mono 10-segment level meters with peak hold, indicate level for Programs 1 and 2.
- Headphone monitor for Master program allows performance rehearsal with Master level turned down.
- Stereo Headphone Cue pans between Program 1 and Program 2.

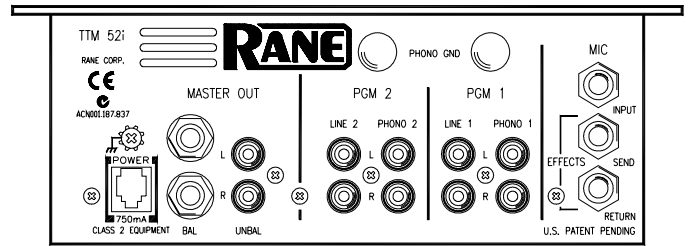

Rear View

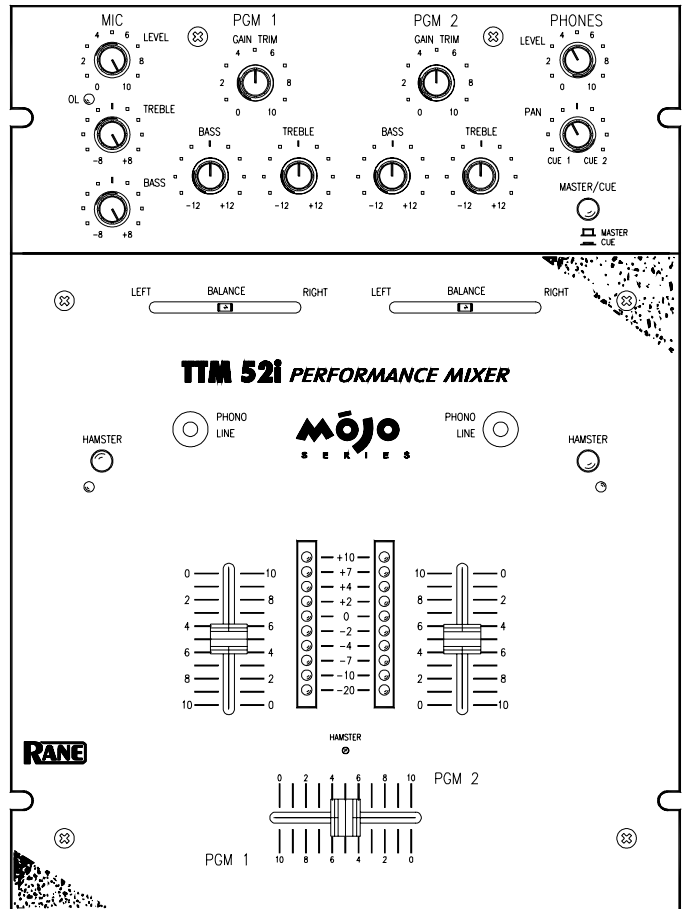

Top View

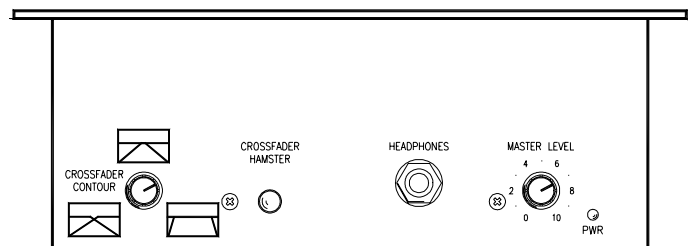

Front View



**TTM 52i**  
PERFORMANCE MIXER

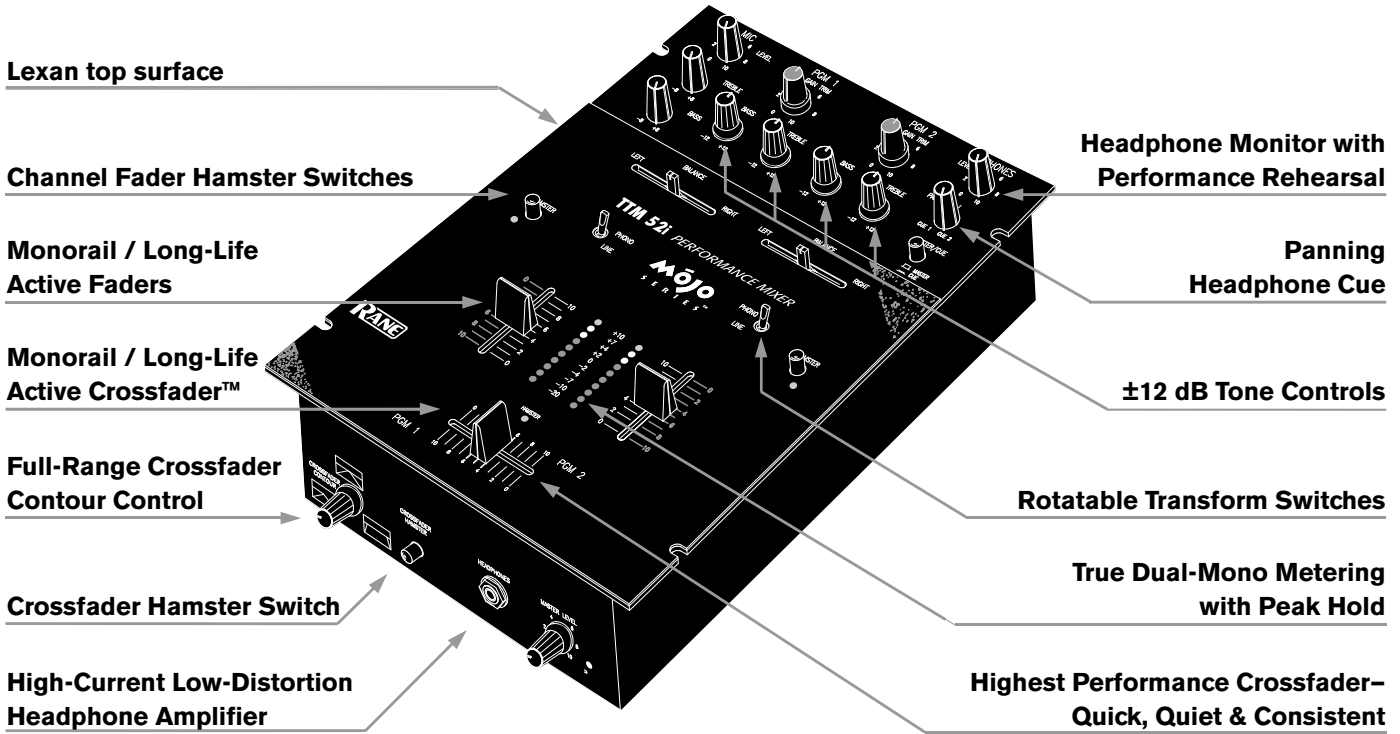

**The origin of Hamster—**

A few years back, there was a crew of turntablists who called themselves *The BulletProof Scratch Hamsters*. They approached several mixer manufacturers with an idea for “reversing” the crossfader program material. In other words, they wanted to have Program A appear where Program B was, and vice versa. This idea was intriguing enough to make one manufacturer comply and they began offering this feature on a popular model (internally). In turntablist circles the reversal feature is referred to as *Hamster* in homage to the idea originators. This capability has evolved to a point where the performer wants (maybe needs) to *Hamster* on the fly instead of opening the mixer up and selecting one way or the other. Rane has obliged this growing request by allowing the artist to reverse on the fly with the crossfader and, uniquely, with the up and down faders as well.

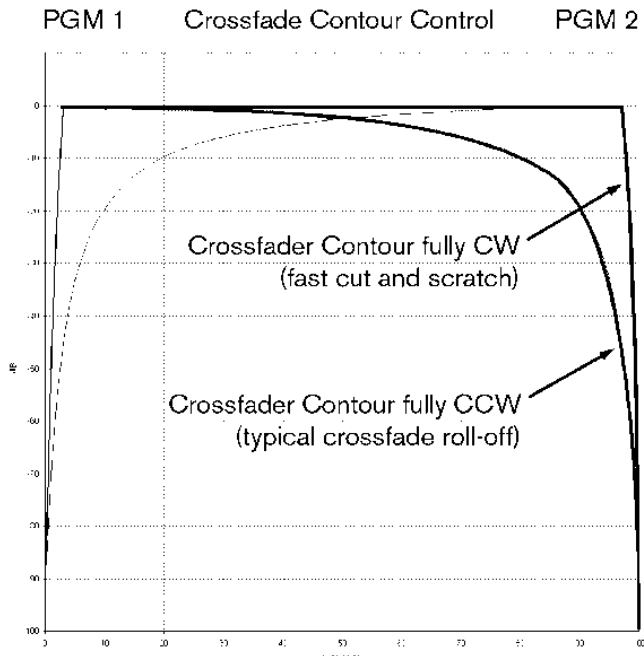
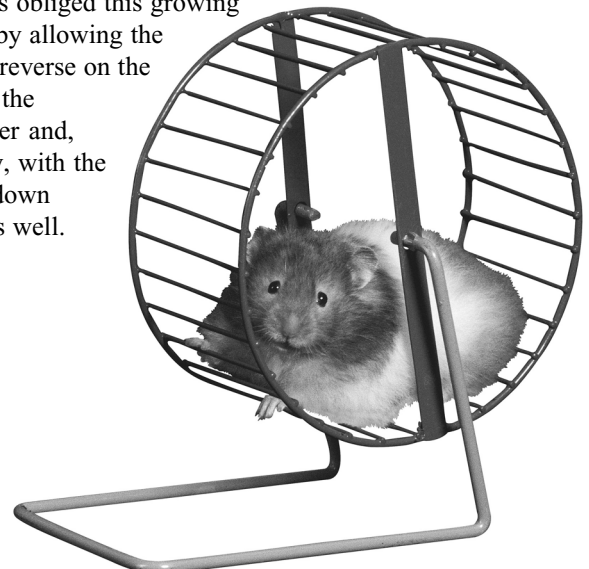

Figure 1. Crossfader Contour control



*Lexan is a registered trademark of GE*

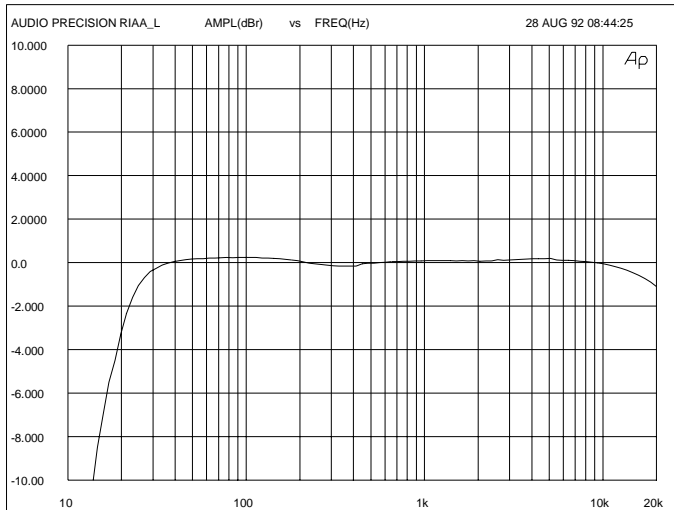

Fig. 3: Phono Response (using inverse RIAA)

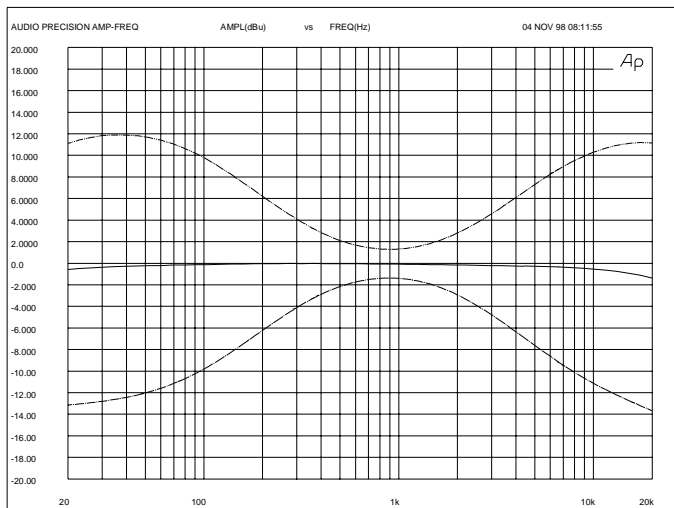

Fig. 4: Program Tone Controls

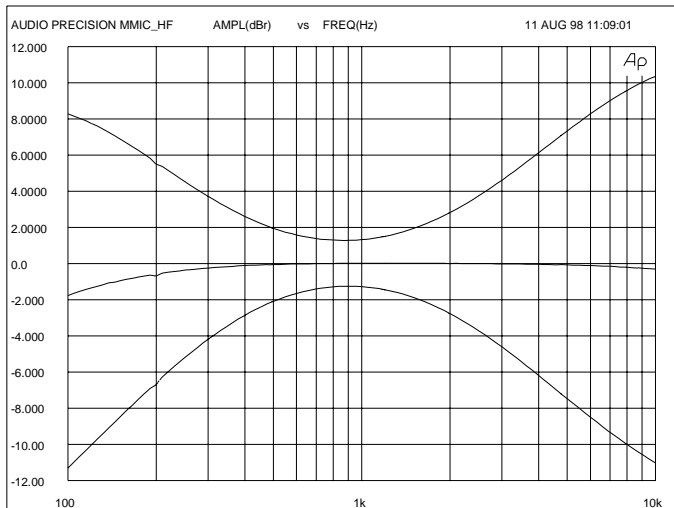

Fig. 5: Mic Tone Controls and Overall Response

Parameter	Specification	Conditions
<b>Phono Inputs:</b>	RIAA	See Fig. 3
...Number	2 Stereo	
...Gain	40 dB	1 kHz
...Rumble Filter	20 Hz	18 dB/oct. Butterworth, See Fig. 3
<b>Line Inputs:</b>	2 Stereo	
...Gain	12 dB	unbalanced out
...Gain	18 dB	balanced out
...Frequency Resp.	10 Hz-30 kHz	+0,-3 dB
...Noise	-98 dB	re +4 dBu, 20 kHz BW, unity gain
	-87 dB	re +4 dBu, 20 kHz BW, Max. gain
...THD+N	<0.1%	re 0 dBu, 20-20 kHz, 80 kHz BW
...Control Feed-through	<-80 dB	re +4 dBu, all controls
...Crosstalk	<-70 dB	re +4 dBu, 1 kHz
<b>Mic:</b>	Balanced	1/4" TRS
...Gain	60 dB	balanced output maximum gain
...Response & EQ	See Fig. 5	
...Noise	-70 dB	re +4 dBu, 20 kHz BW, Max. gain
...CMRR	>40 dB	re +4 dBu, 1 kHz
...Effects Loop	Independent, Non-Switched	
<b>PGM Tone Controls:</b>	±12 dB	
...Response	See Fig. 4	
<b>Metering:</b>	Dual Mono, 10 Segment	
	Post Program Fader; 1 sec. peak hold	
	Indicator Turn-on Blanking	
<b>Max. Current:</b>	750 mA RMS from remote supply	
<b>Unit: Agency List</b>		
...120 VAC model	Class 2 Equipment UL CSA	National Electrical Exempt Class 2 Exempt Class 2
...230 VAC model	CE-EMC CE-Safety exempt art. 1 LV 73/23/EEC	EMC 89/336/EEC
<b>Power Supply: Agency List</b>		
...120 VAC model	UL CSA	File E88261 File LR58948
...230 VAC model	CE-EMC CE-Safety	EMC 89/336/EEC LV 73/23/EEC
<b>Unit: Size</b>	3"H x9"W x11.75"D (7.6 x23 x30 cm)	
<b>Shipping: Size</b>	7.5" x 20" x 10.5"	(19 x 51 x 27 cm)
...Weight	11 lb	(5 kg)

Note: All specifications are typical unless otherwise stated.



# TTM 52i

## PERFORMANCE MIXER



### Block Diagram

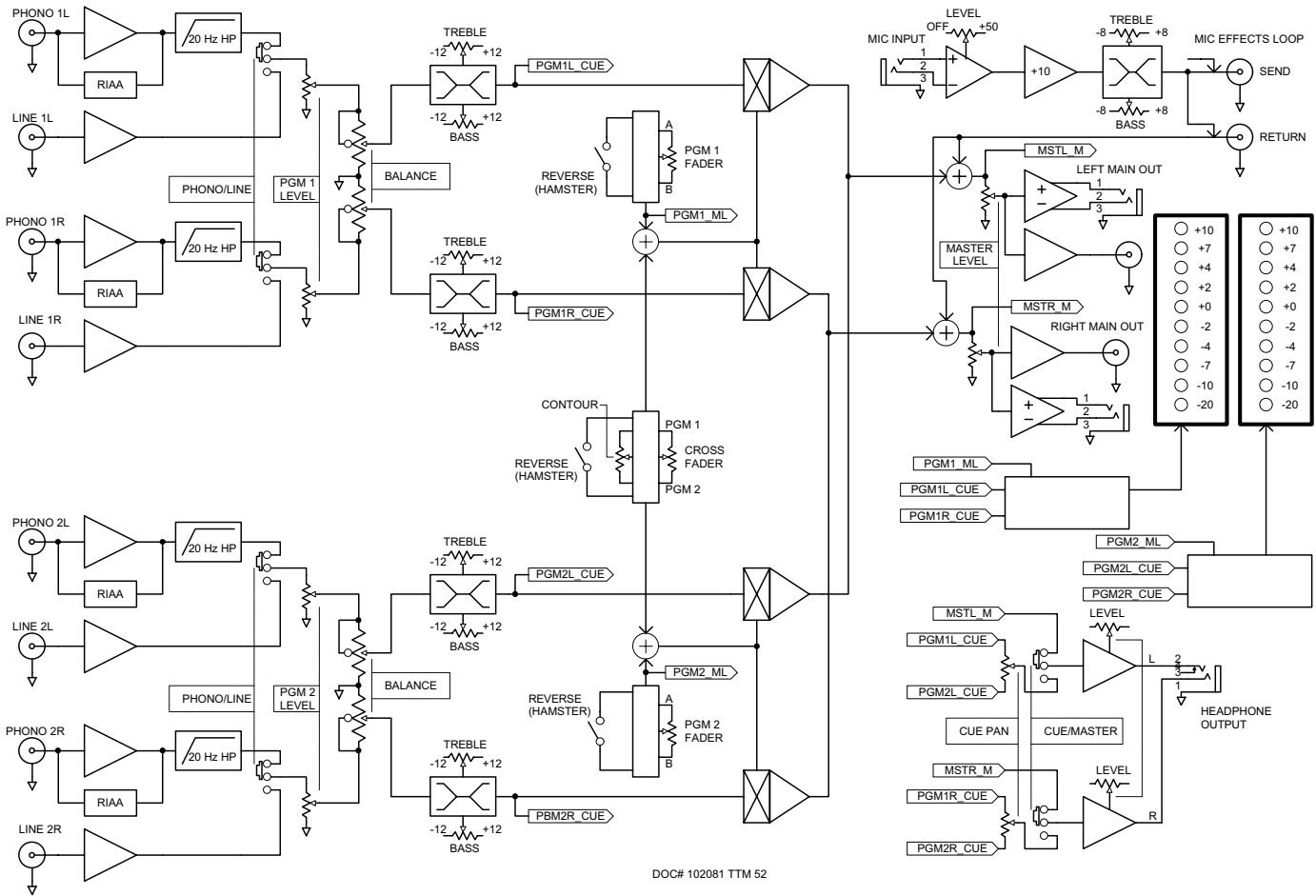

DOC# 102081 TTM 52

#### FEATURE

FEATURE	RANE TTM 54i PERFORMANCE MIXER	RANE TTM 52i PERFORMANCE MIXER	BRAND X PERFORMANCE MIXER
Accelerated-Slope™ 40 dB Cut Tone Controls	YES (+10, -40)	NO (±12 dB)	NO (±15 dB)
Assignable Effects Loop	YES (PGM 1, PGM 2 or Master)	NONE	NONE
Highpass Rumble Filters	YES (18 dB/Oct., each phono input)	YES (18 dB/Oct., each phono input)	NONE
Long-Life, Low-Noise Active Input Faders	YES	YES	NO (passive)
Front Panel Input Fader Contour Control	YES	NO	NO (internal 3-position)
Input Fader Hamster Reversal Switch	YES	YES	NO
Long-Life, Low-Noise Crossfader	YES (VCA)	YES (VCA)	YES (light-driven resistor)
Crossfader Contour Control	YES (high accuracy, active)	YES (high accuracy, active)	YES
Crossfader Hamster Reversal Switch	YES	YES	NO
High Output, Low Distortion Headphone Amp	YES (200 mW @ .1% THD+N, 150 Ω)	YES (200 mW @ .1% THD+N, 150 Ω)	NO (25 mW @ 1.2% THD+N, 150 Ω)
True L+R Dual Mono Metering With Peak Hold	YES	YES	NO (left channel only/no peak hold)
High Resolution Meter Display	YES (10 segment)	YES (10 segment)	NO (7 segment)
Mic Effects Loop	YES	YES	NO
Greater Than 110 dB Dynamic Range	YES	YES	NO (<100 dB)
High-Quality, Glass Epoxy PCBs	YES (double-sided)	YES (single-sided)	NO (single-sided phenolic)
Made In the USA	YES	YES	NO