

General Description

The SRM 66 provides a cost effective solution for systems requiring any combination of zone distribution, room combining, and remote level control. Split, route, and mix functions are implemented with a six input, six output matrix mixer. The SRM 66 allows independent routing and mix-level adjustment of any Input to any Output.

Control consists of a backlit LCD, five buttons and a Data wheel. All programming is accomplished using eleven easily accessible edit pages. Six pages control Output programming, four for Group programming and one for Memory functions.

Inputs and Outputs are line-level balanced and equipped with Euroblock connectors. Rear panel Gain switches on each Input and Output allow -10 dBV or +4 dBu sensitivity. Front panel Mix Input Headroom LEDs indicate the remaining headroom for each of the six inputs at 4 dB and 16 dB.

Programmable Output Limiters prevent mixer overload. If Output level exceeds the Limit Threshold, all six mix levels for the given Output are reduced, maintaining the proper mix.

Each Output features an internally switchable 2nd-order 80 Hz Highpass filter. These filters are useful in conjunction with constant-voltage line transformers or small sound-reinforcement speakers.

The SRM 66 uses Output Groups to “link” attenuation levels and Limiter gain reduction of one or more Outputs. Outputs may be assigned to one of six Output Groups. For example, a stereo Output pair would typically be assigned to the same Output Group. This ensures that they limit together and are controlled by a common Output Group attenuation or Remote. Output Group Levels are the only parameters *not* affected by Memory changes.

Outputs are assigned to any one of the six possible Output Groups or none. Remotes are then assigned to any one of the six possible Output Groups or to the Master Group. The Master Group is configured by assigning any number of the six possible Groups to the Master Remote. For example, you have a six zone system and have a Remote assigned to control the level in each

zone. You can then assign any number of the Output Groups to the Master Remote, allowing all zones to be controlled by one Remote.

Mix configurations are saved in up to 24 non-volatile Memories stored in EEPROM, requiring no batteries. Memories may be recalled via the front panel LCD screen or the rear panel Memory Recall Port (MRP). The MRP allows remote contact closures to recall any of the 24 Memories. Advanced MRP users can completely program the MRP closure-to-memory-mapping functions via *SRM Exchange* software and the Rane DSC 1 accessory. The optional Rane MRS 4, RCP 3 and RCP 4 connect to the MRP for easy room combining and memory recall.

The SRM 66 provides a Remote Interface Port (RIP) which supports up to seven optional SR 1L “Smart” digital Remote controls. Each Remote may be assigned to any one of the six possible Output Groups or to the Master Group. The Remotes control the level of a Output Group, not Output level. Each of the Memories stored in the SRM 66 may have unique Output Group assignments for Outputs and SR 1L Remotes. This allows flexible room combining and system reconfiguration. All Remotes assigned to an Output Group display the level of the Output Group. The Remote Interface Port is a powered, half duplex, (RS-485) party line system using 5 wires, allowing any combination of “star” and/or “chained” wiring. The SR 1L also supports encoder lockout and Master/Slave functionality where one remote controls Output Groups across multiple SRM 66s.

The FP Lock function locks out all front panel SRM 66 control except for Output Group Levels and Memory Recall. The SR 1L Remotes can still control Output Group Levels with the FP Lock rear panel switch engaged. With FP Lock, all edit pages are viewable but not changeable.

The SRM 66 and SR 1Ls can be controlled via AMX or Crestron room controllers using the SRM 66’s (RS-485) Remote Interface Port (see RaneNotes “Using a Control System with and SRM 66” and “Using SR 1Ls with other Rane Products”). All RaneNotes are available at www.rane.com.

Features

- 6 Inputs Split, Route and/or Mix to 6 Outputs
- Programmable Input Mix & Output Level Controls & Limiters
- Programmable Output & Remote Output Group Assignments
- Master Group Level Capability (remote optional)
- Up to Seven SR 1L Digital Remotes (optional)
- 24 Non-Volatile EEPROM Memories with Remote Recall
- Balanced Euroblock Input and Output Connectors

Applications

- Programmable Split, Route, Mix and/or Level control
 - Via front panel, wired remote or RS-485 room controllers
- Room Combining; Stand alone or with room controllers
- Remote Level Control for multi-zone applications
 - One to six remotes can control many fluctuating zones
- Pro & Consumer Voltage Friendly



Parameter	Specification	Limit	Units	Conditions/Comments
Inputs: Type	Active Balanced			
.....Connectors	Euroblock			
.....Impedance	20k	1%	Ω	
.....Maximum Level	+14	1	dBu	-10 dBV gain
	+26	1	dBu	+4 dBu gain
.....Mix Range	+6 to -25 and Off		dB	1 dB steps
Outputs: Type	Active Balanced			
.....Connectors	Euroblock			
.....Impedance	200	1%	Ω	
.....Maximum Level	+8	1	dBu	2k Ω load, -10 dBV gain
	+20	1	dBu	2k Ω load, +4 dBu gain
.....Master Level Range	+0 to -59 and Off		dB	1 dB steps
Control Group Attenuation	+0 to -29 and Off		dB	1 dB steps
Limiter: Threshold Range	0 (Max) to -28		dB	relative to max. sig. level, 1 dB steps
.....Attack Time	150		ms	10 dB step
.....Release Time	500		ms	10 dB step
High Pass Filter (switchable)	80	3%	Hz	2nd order, 12 dB/octave, Butterworth
RFI Filters	Yes			
Mix Input Headroom Meter	+4 & +16	2	dB	Headroom remaining before clip
Frequency Response	10-25 kHz	typ.	dB	-10 dBV gain
	10-40 kHz	typ.	dB	+4 dBu gain
THD+Noise	<0.1%	.05	%	+4 dBu, 20-20 kHz (80 kHz BW)
Signal-to-Noise Ratio	20 kHz noise BW, unity gain, one Channel, re: +4 dBu			
	90	2	dB	-10 dBV gain input & output
	80	2	dB	+4 dBu gain input & output
Off Isolation	>80	min.	dB	@ 1 kHz, re: +4 dBu
Unit: Agency Listing				
.....120 VAC model	Class 2 equipment U.L. 813 CSA			National Electrical Code Exempt Class 2 equipment
.....230 VAC model	CE (EMC) CE (safety) Exempt			Exempt Class 2 equipment EMC directive 89/336/EEC Exempt per article 1, LVD 73/23/EEC
Power Supply: Agency Listing				
.....120 VAC model	UL CSA			File no. E88261 File no. LR58948
.....230 VAC model	CE-EMC CE-Safety			EMC directive 89/336/EEC LV directive 73/23/EEC
Power Supply Requirement	18 VAC w/center tap	10%	Vrms	
Maximum Current	300		mA	RMS Current from Remote Supply
Unit: Construction	All Steel			"19"" 1U Rackmount"
.....Size	1.75" H x 19" W x 8.5" D (1U)			(4.4 cm x 48.3 cm x 21.6 cm)
.....Weight	5 lb (w/o power supply)			(2.3 kg)
Shipping: Size	4.25" x 20.3" x 13.75"			(11 cm x 52 cm x 35 cm)
.....Weight	9 lb			(4.1 kg)
<i>Note: 0 dBu=0.775 Vrms</i>				

SRM 66 Block Diagram

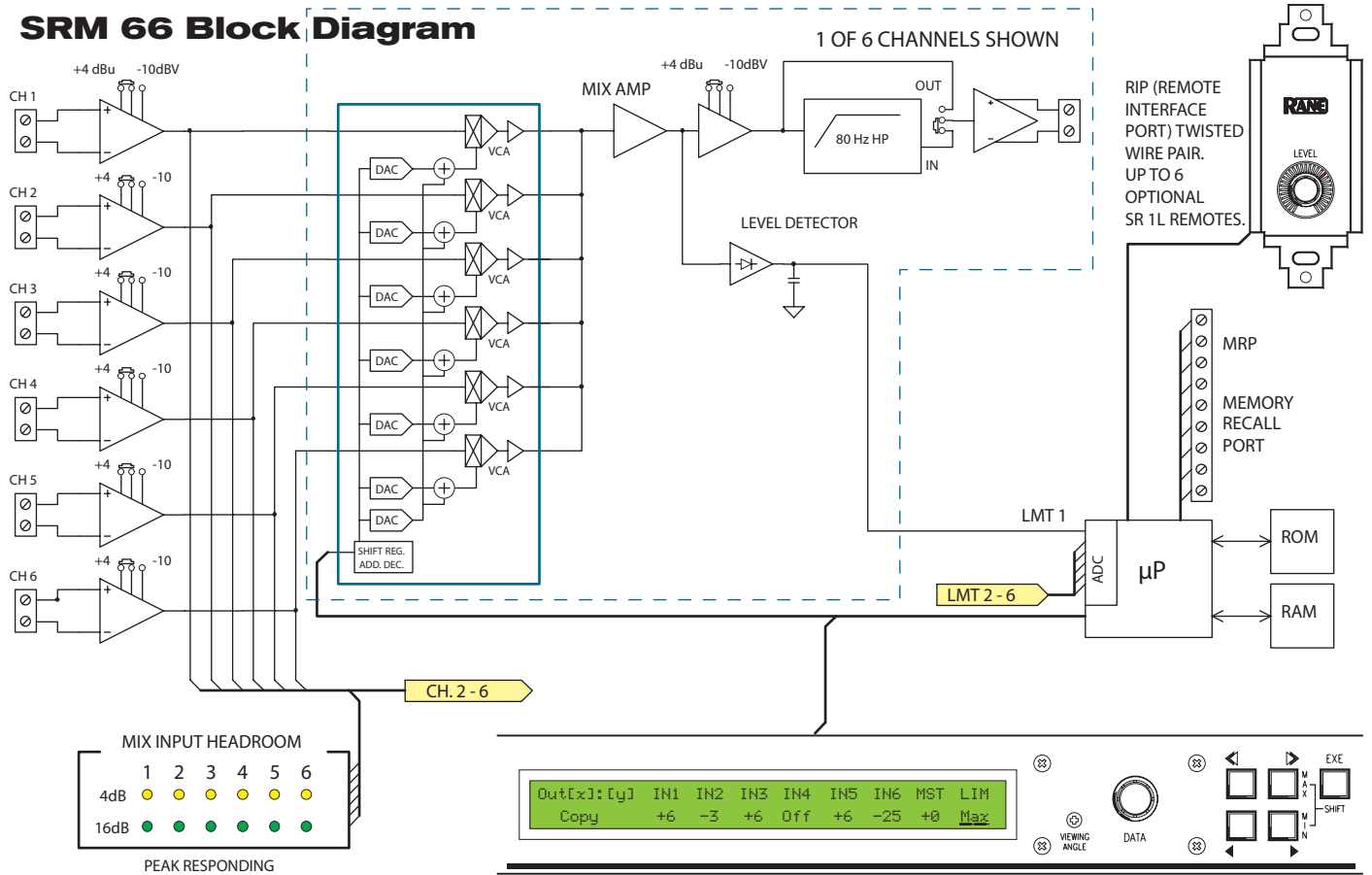

SRM 66 Output Page

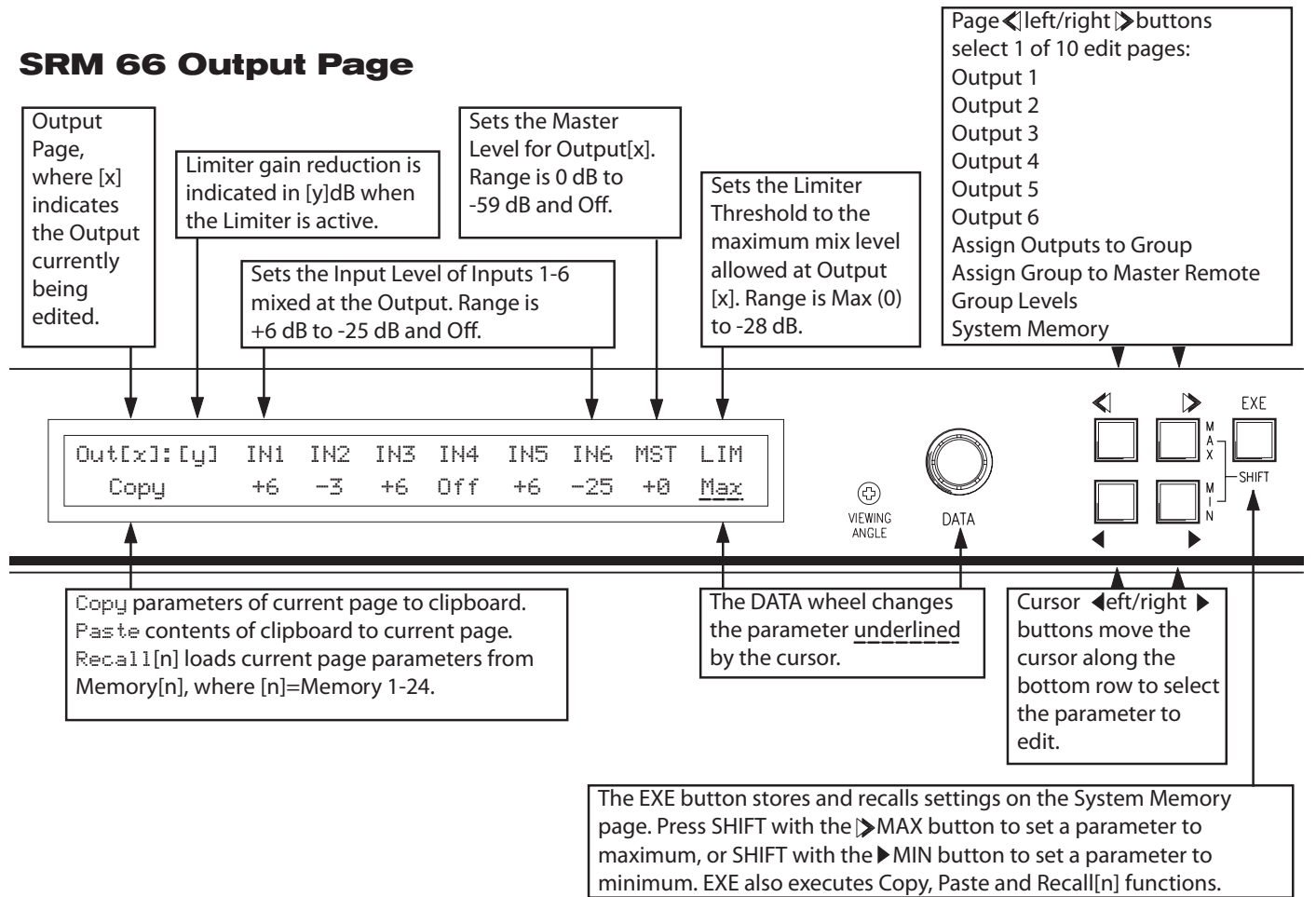

Rear Panel

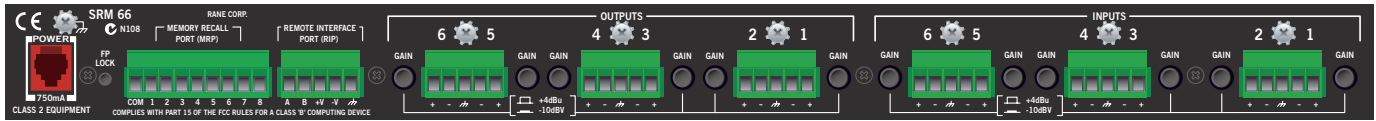

Architectural Specifications

The unit shall have six (6) mono inputs and six (6) mono outputs. The unit shall be capable of simultaneously splitting, routing and/or mixing any input to any output. Each output shall have six input mix level controls with a range of +6 dB to -25 dB, in 1 dB steps, or off. A master output mix level control shall have a range of +0 dB to -59 dB, in 1 dB steps, or off.

Input headroom meters shall be provided for each of the six inputs by means of front panel LEDs.

Programming shall be accomplished via the front panel backlit LCD display and five (5) momentary buttons with a data wheel. An adjustment for LCD viewing angle shall be provided.

Limiters shall be provided on each output. The limit threshold shall be adjustable in 1 dB steps from 0 dB (Max) to -28 dB re: clip.

An 80 Hz high-pass filter shall be provided on each output. This filter shall be bypassable with an internal switch.

Provisions to link attenuation level and limiter gain reduction of output combinations shall be provided in the form of Output Groups.

A Remote Interface Port shall be provided permitting the use of up to seven (7) SR 1L Smart digital Remote controls for the purpose of adjusting Output Groups from a remote location. Each SR 1L remote shall install into a standard US electrical box at least 2¼ inches deep.

A memory recall port shall be provided to recall any memory via contact closure.

The inputs and outputs shall be line-level, active balanced designs terminated with Euroblock connectors. RFI filters shall be provided.

The unit shall be exempt from agency safety requirements and powered from a UL listed / cUL certified remote power supply (120 VAC), or meeting CE requirements (230 VAC).

The unit chassis shall be constructed entirely from cold-rolled steel, and mount into a standard 1U EIA rack.

The unit shall be a Rane Corporation SRM 66 Splitter Router Mixer.

Additional Reading

1. RaneNote, "Using a Control System with an SRM 66"
 2. RaneNote, "Using SR 1L's with other Rane Products"
 3. RaneNote, "Advanced Applications of the Ingenious SRM 66 and SR 1L"
- RaneNotes are at www.rane.com.



Accessories

SR 1L Smart Digital Remote

The Rane SR 1L provides remote level control for one Output Group of an SRM 66. The SR 1L's 31 LEDs indicate the Output Group's current setting of 0 to 29 dB of attenuation (in 1 dB steps) and OFF. It fits in a standard U.S. electrical box, and can be covered with a standard Decora™ plate cover. Up to seven SR 1Ls can be connected to a single SRM 66. See the SR 1L Data Sheet.

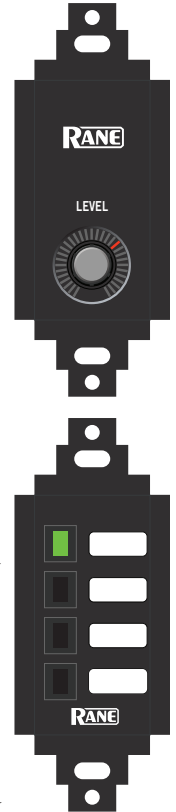

MRS 4 Memory Recall Switch

The MRS 4 provides a simple solution to recalling SRM 66 Memories from a remote location via the Memory Recall Port. It fits in a standard U.S. electrical box, and can be covered with a standard Decora™ plate cover. If connected in normal mode, up to 4 Memories can be recalled. See the MRS 4 Data Sheet.

DSC 1 Digital Serial Converter

The DSC 1 provides a bridge to connect a PC's RS-232 port and the Remote Interface Port of the SRM 66. Coupled with the included SRM Exchange™ software, the DSC 1 allows an exchange of settings between an SRM 66 and the PC. Once the settings are obtained by the PC they can be manipulated, stored in a file, printed for future reference or sent to another SRM 66. See the DSC 1 Data Sheet.

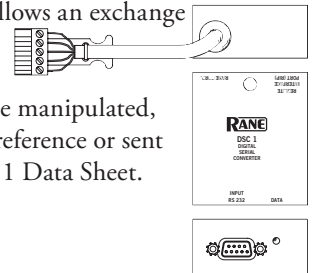

RCP 3 Room Combining Panel

RCP 4 Room Combining Panel

The RCP 3 (three-room combining panel) and RCP 4 (four-room combining panel) connect to the SRM 66's Memory Recall Port to create a "room combining system" using preset Memories in updated SRM 66's.

The RCP 3 and RCP 4 panels mount in a standard 19" rack and utilize a single rack space. See the RCP Data Sheet.