

CONTENTS

Quick Start	2
Front Panel Description	3
Rear Panel Description	4
Working with Smart Remotes	5
SR 2 Wiring Guidelines	10
SR 2 Communication Protocol	18
Smart Remote Specifications	28
Factory Authorized Service	30
Limited Domestic Warranty	30
Warranty Procedure in USA	32
Declaration of Conformity	34

**FCC Statement**

NOTE: This equipment has been tested and found to comply with the limits for a Class B digital device, pursuant to part 15 of the FCC Rules. These limits are designed to provide reasonable protection against harmful interference in a residential installation. This equipment generates, uses and can radiate radio frequency energy and, if not installed and used in accordance with the instructions, may cause harmful interference to radio communications. However, there is no guarantee that interference will not occur in a particular installation. If this equipment does cause harmful interference to radio or television reception, which can be determined by turning the equipment off and on, the user is encouraged to try to correct the interference by one or more of the following measures:

- Reorient or relocate the receiving antenna.
- Increase the separation between the equipment and receiver.
- Connect the equipment into an outlet on a circuit different from that to which the receiver is connected.
- Consult the dealer or an experienced radio/TV technician for help.

CAUTION: Changes or modifications not expressly approved by Rane Corporation could void the user's authority to operate the equipment.

This Class B digital apparatus complies with Canadian ICES-003.

Cet appareil numérique de la classe B est conforme à la norme NMB-003 du Canada.



SR 2

SMART REMOTE OPERATORS MANUAL

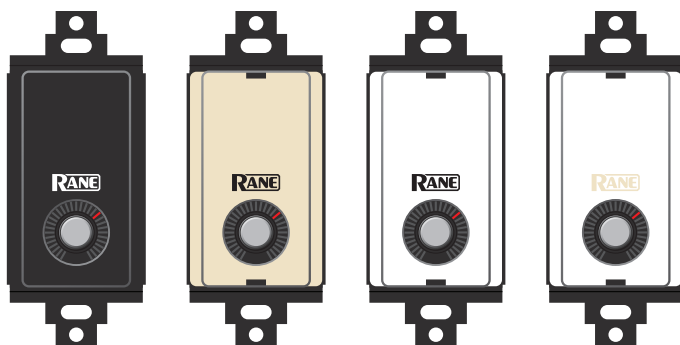

Quick Start

Who would guess that a little box with one knob could have such a thick manual? At least read this section for the basics.

Architectural look. Since Decora plates come in different colors, each SR 2 is shipped with 4 different color inserts for installation behind the lens (we ship them without an insert installed). Colors included are white (w/ black logo), white (w/ almond logo), almond (w/ black logo) and black (w/ white logo) which accommodate most applications. If the architect or interior decorator requires a custom color, a template is available on the SR 2 page at www.rane.com/sr2.html allowing a custom insert to be printed and cut to the proper size. (No, you cannot return the unused inserts for credit. Please recycle them, keep them as backups or build a house of cards with them).

Address. Set the Device Address rotary switch on the side of the SR 2; addresses from 0 through 7 are valid. Each device connected to the same RS-485 bus must have a unique address.

Wiring. Use CAT 5 cable with a minimum of 2 twisted pairs to connect to the SR 2. The use of DOG 4 cable may cause random barking in high traffic areas. Connect one twisted pair of wires to the “-V” and “+V” terminals – “-V” must connect to the power supply ground and “+V” must connect to +8 to +15 volts. Connect the second twisted pair of wires to the “A” and “B” terminals; “A” connects to the RS-485 “data +” connection and “B” connects to the RS-485 “data -” connection.

Setup software. The SR 2 is configured using Drag Net software included in the box or available at www.rane.com/dragnet. See “Working with Smart Remotes” on page 5.

WEAR PARTS: This product contains no wear parts.

Manual-2

Front Panel Description

- ① **Colored insert** (4 colors included).
- ② **Clear lens** helps support different color templates which mount behind the lens.
- ③ **LED indicators.** Indicate the current “level” of the linked parameter(s).
- ④ **Encoder Knob with momentary push switch** is the user input to the SR 2.

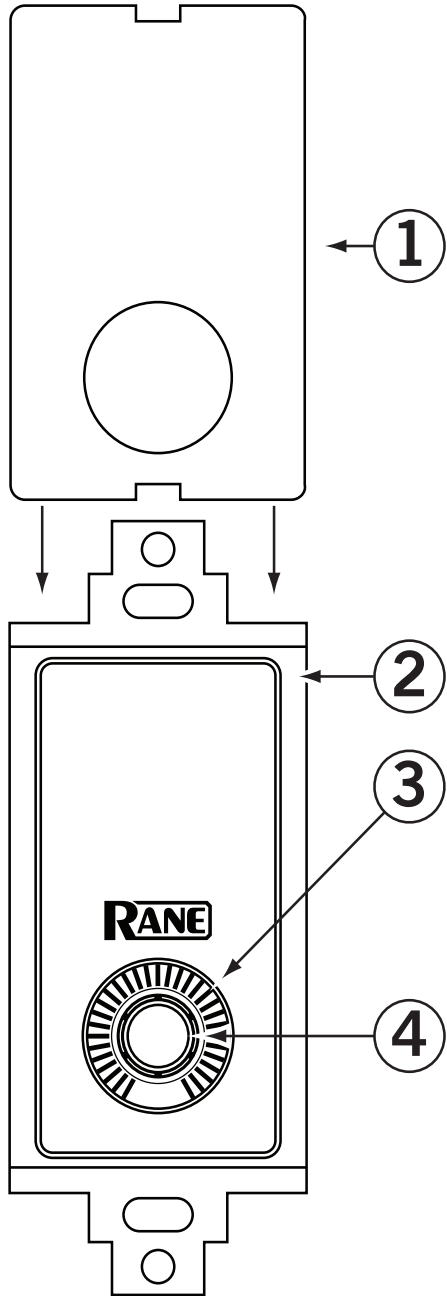

Rear Panel Description

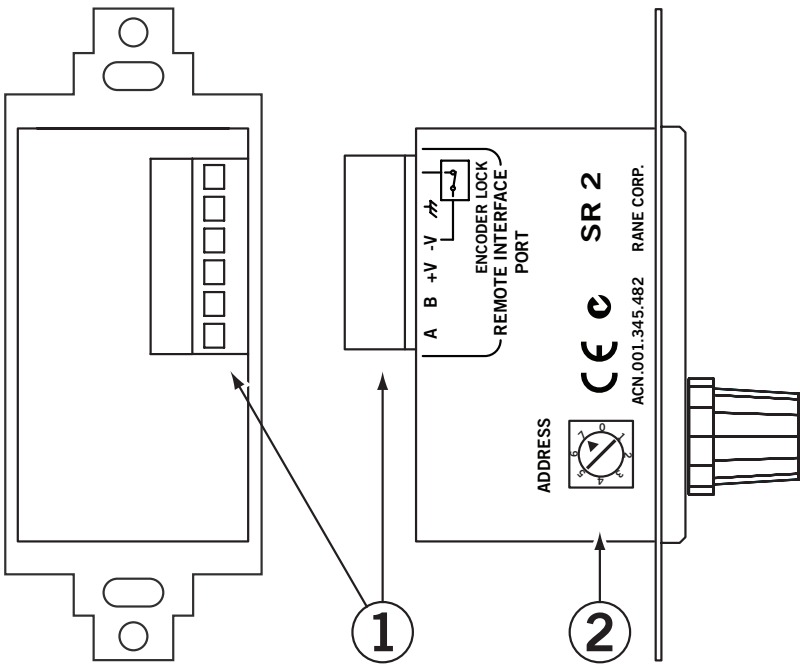

- ① **6-wire Euroblock connector.** Connects the SR 2 to a controller. **A** connects to RS-485 data +, **B** connects to RS-485 data -. **+V** is the positive side of the power supply rail. **-V** is the negative/ground side of the power supply rail. Ground is the connection point for the shield when shielded cable is used. When the Encoder Lock pin is grounded and Auto Lock is enabled, encoder input is ignored by the SR 2. This, for example, allows a keyed switch to be installed next to the SR 2 that allows the device to be “locked” so only keyholders can change system volume.
- ② **Device Address switch** to assign the device its RW 485 address. Addresses 0 through 7 are valid.

Working with Smart Remotes

Smart Remote Overview

Smart Remotes are configured within Drag Net 4 and higher. The following sections describe configuring the various parameters and modes for the remotes themselves. Details on assigning remotes to control parameters and functions with an RPM are found in Drag Net's included Help file (Help > Help Topics).

Creating a new Configuration

Smart Remote configurations can be created as offline Storage files, for subsequent transfer to a Live remote. To create a new Smart Remote Configuration:

1. Click the **File** menu, choose **New**, then select **Configuration** (CTRL + N).

- or -

Click the **New Configuration** button in the standard toolbar.



- or -

Right-click within the Project window and select **New**, then **Configuration** (CTRL + N).

2. Select the configuration source, either from an empty configuration, or from an existing Rane- or User-defined template. Select a device type from the **Configuration Type** list to filter the list of file options (to only show SR 3 files in the User Template directory, for example). Selecting the **Copy Settings** check box copies all parameters to the new configuration. This is a particularly useful feature when creating new configurations based on existing User Templates.

3. Select a configuration type (SR 2, SR 3, SR 4) from the list of choices.

4. Click **Next**

5. Enter a Name, storage location on your hard drive, and brief description of the configuration.

6. Click **Finish** and start configuring the remote!

File extensions for Smart Remote configurations follow the remote type – SR 2 configurations are stored as .sr2 files, for example.

Each remote has a number of configuration parameters which determine basic functions and user operation modes. These parameters are stored locally on each remote in non-volatile memory.

SR 2 Configuration Parameters

The SR 2 features a 31-position LED indicator and rotary data encoder with integrated push switch. The push switch permits control of two independent parameters: Level 1 when the encoder is rotated normally, and Level 2 when the encoder is pushed and held while rotating. Each SR 2 ships with four face-plate inserts: white (w/black logo), white (w/almond logo), almond (w/black logo) and black (w/white logo).

Auto Lock

Auto Lock is used in conjunction with the SR's Encoder Lock pin to disable the SR encoder. When the Encoder Lock pin is grounded and Auto Lock is enabled, changes in position of the encoder are ignored by the SR. For example, a keyed switch installed next to the SR allows the device to be locked temporarily so the system volume can not be adjusted.

Knob Turn

When **Auto Level** is enabled and the encoder is turned normally (without pushing it in) the LED moves clockwise or counterclockwise one position in the direction the knob was turned.

Always enable **Auto Level** when using a Smart Remote with a Rane RPM device.

Knob Push & Turn

When **Auto Second Level** is enabled and the encoder is held in, the LED begins flashing and displays the second level until the encoder is released. The second level is adjusted by turning the encoder knob while continuing to hold it in.

Polling for Remotes

Ethernet versus Serial Communication

If Smart Remotes are connected to an RPM device, the RPM acts as a data bridge, allowing communication with the remote through the Ethernet connection to the RPM. Smart Remotes appear beneath the RPM device in the Live folder of the Project window.

Serial communication takes place through the PC's COM port, which is usually RS-232 and therefore must be connected to the SR using an RS-232 (unbalanced data) to RS-485 (balanced data) converter capable of supporting the desired baud rate. Select the COM port connected to the SR from the list of available ports when polling for Live devices.

Baud Rate

The Baud Rate can only be set when Serial Mode is selected during polling. When configuring Remotes used with Rane controllers (i.e., RPM 88/44/22), the RW 485 baud rate of 38400 bps is automatically set. Should you encounter communication problems, settings can be restored to 38400 baud, 10 ms delay by holding the encoder in while powering the remote. Release the encoder when its LED lights.

Transferring Configurations to and from a Live Remote

Remotes can be configured offline in Storage mode, then transferred to a Live remote when you get to the job site. Alternately, you can transfer the contents of a Live remote to an offline Storage configuration as a backup, or for editing when you're back in the comfy chair at the office.

Storage to Live

Live remotes are initialized by transferring a Storage configuration to a Live remote. This action replaces all settings on the remote. Once the transfer is complete you can continue to work directly with the Live remote, adjusting mode parameters, inserting bitmaps (SR 3), and so on. Hint: You'll need to **Poll for Live devices** before transferring configurations. To transfer a Storage remote configuration to a Live device:

1. Toggle the Project Window on if it's not already visible (**View > Project**).
- 2a. Drag and drop the Storage configuration listed under the Storage folder onto a destination remote listed under the Live folder.
 - or -
- 2b. Select the Storage configuration, click the **Transfer Config To** button, and then select a destination remote from the list.
 - or -
- 2c. Right-click the Storage configuration and choose **Transfer To**, then select a destination remote from the list.

Live to Storage

Important: Transferring from a Live remote to an existing Storage configuration overwrites the Storage configuration. To transfer from a Live remote to a Storage configuration:

1. Toggle the Project Window on if it's not already visible (View > Project).
- 2a. Drag and drop the Live remote onto an existing destination Storage configuration.
- or -
- 2b. Select the **Live remote**, click the **Transfer Config To** button, and then select a destination Storage configuration from the list, or choose to create a new configuration.
- or -
- 2c. Right-click the **Live remote** and choose **Transfer To**, then select the destination Storage configuration from the list, or choose to create a new configuration.

Editing a Live Remote

It is possible to edit any parameter on a Live remote directly, without first having to transfer a Storage configuration to it.

To view the current contents of a Live remote simply double-click the remote listed under the Live folder of the Project Window. Alternately, right-click the **Live remote** and choose **Open item**. The contents of the Live remote are then loaded into the Device Configuration window for viewing and/or editing.

Renaming a Remote

To rename a Smart Remote:

1. Right-click the **Live remote** in the Project window and choose Properties.
2. Enter a new name for the remote in the Name field.

Updating Smart Remote Firmware

It may be necessary to update a Smart Remote's firmware in order to add features or address one of those pesky glitches that only seem to appear after the product's been released.

Remotes with the following firmware versions can be upgraded as new firmware becomes available:

Remote	With Firmware Version
SR 2	2.0 and higher
SR 3	4.0 and higher
SR 4	1.0 and higher

Older remotes may not be updateable, or updateable only by Rane. Contact Rane Tech Support 425-355-6000 or visit www.rane.com for more information.

Firmware files for all remotes are installed as part of Drag Net and are located in the Program Files\Rane Corporation\Drag Net\Firmware\Smart Remotes directory.

To update firmware in a Smart Remote:

1. Ensure remotes are properly connected to the RPM device. Remotes must be connected before powering the RPM on.
2. Connect directly to the RPM device, using an Ethernet crossover cable.
3. Poll to find the Live device. Remotes are listed beneath the RPM device in the Project window.
4. Select the Remote to be updated.
5. Launch the **Update Device Firmware Wizard** (Tools > Update Device Firmware).
6. Follow the wizard's on-screen instructions to complete the operation. The device automatically resets itself once the update is complete.

Firmware updates performed using a COM Port (Serial) follow the exact same steps, beginning with Step 3.

SR 2 Wiring Guidelines

Restrictions

24 AWG CAT 5 cable resistance = 26 ohms per 1,000 feet. There are two wiring restrictions. First, RW 485 has a maximum of 1,000 feet. The total length may not exceed this limit in any combination of series or parallel runs.

Second, the voltage of the power supply also affects the maximum distance of each length between, and the number of Remotes. Refer to the tables on the following pages depending on which wire, voltage, number of Remotes, and if you are using single or multiple runs.

External Power Supply

The RPM 88's RW 485 port does not offer enough current to power more than seven SR 2 remotes — an external DC supply must be used. Rane recommends using a 12 to 15 volt DC regulated power supply capable of delivering a minimum of 1 amp of current. The combined current draw on the RPM 88's RW 485 port and VOP cannot exceed 375 milliamps. [The RPM 44 and RPM 22, however, can power up to eight SR 2 remotes.]

Most installations will have a mix of SR 2, SR 3, and SR 4 remotes each with their own current requirements. To make calculation easy as to whether or not an external supply is necessary, a Microsoft Excel™ spreadsheet is available named SRXCABLELENGTHS.XLS. This file is on the Drag Net CD-ROM, or downloadable from www.rane.com/smart.html.

If you have a Radio Shack nearby, they offer a 15 volt 1 amp supply, catalog number: 273-1691. To ease installation, use a 6 foot Adaptaplug extension cable, Radio Shack catalog number 273-1641.

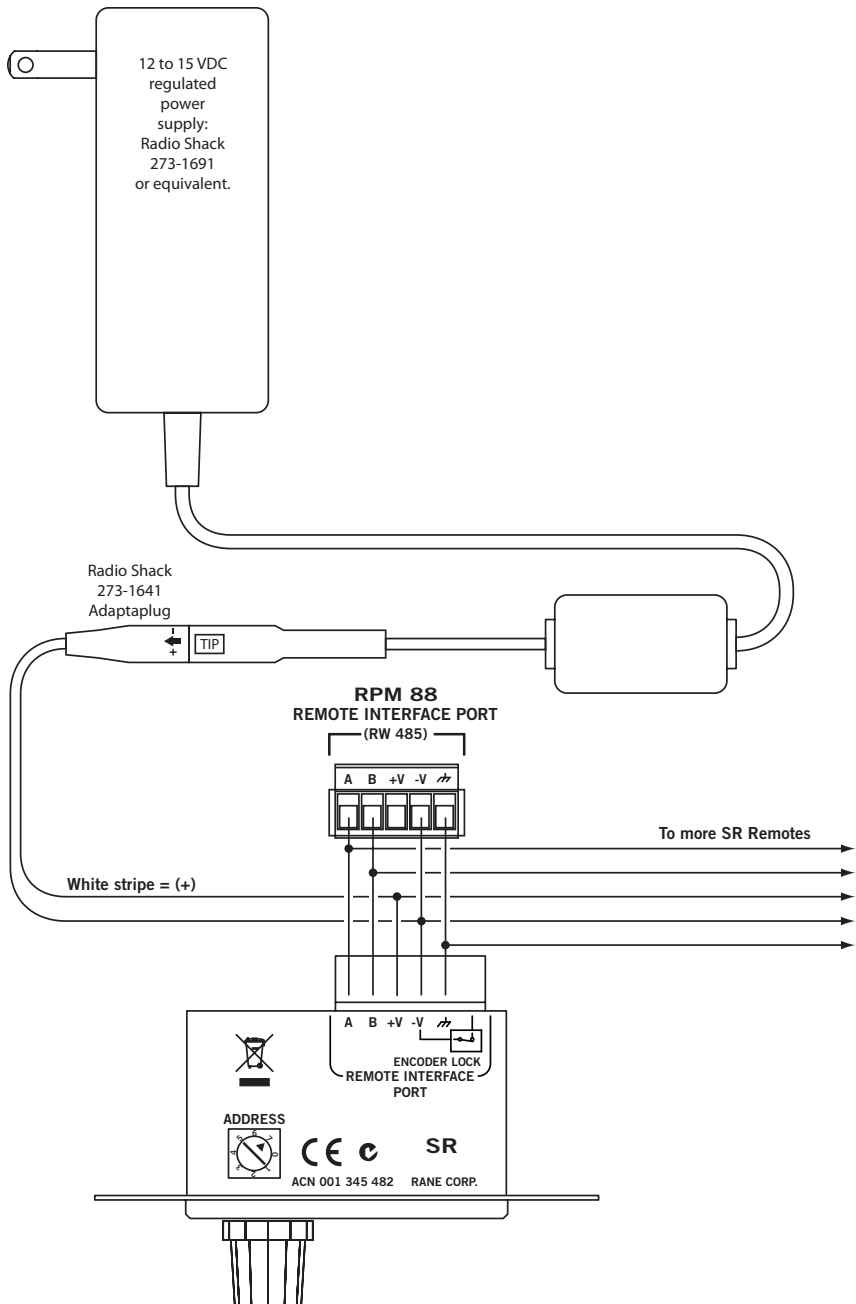

Cable Type 1

2 twisted pair unshielded CAT 5, Belden #1588(A,R)

2 twisted pair unshielded CAT 5, Belden #1590A

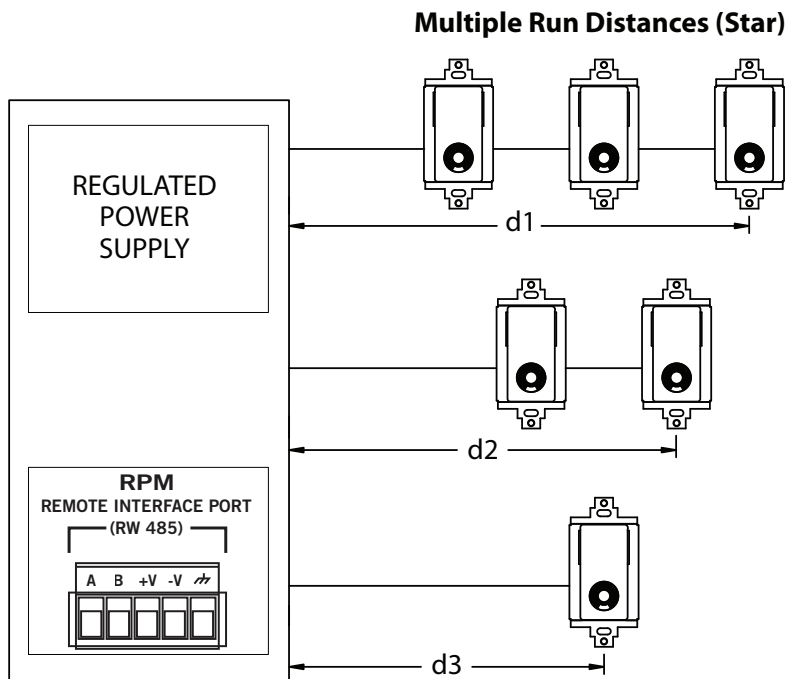
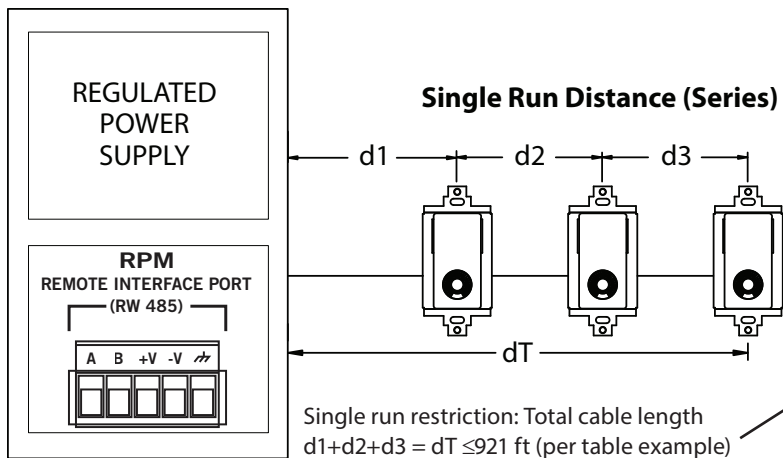

Cable Type 1

2 twisted pair unshielded CAT 5, Belden #1588(A,R)

2 twisted pair unshielded CAT 5, Belden #1590A

	Max Distance for Cable (feet)	Max Distance for Cable (meters)	Number of SR 2 Remotes
Vs = 15V RPM 44 RPM 22	1000	305	1
	1000	305	2
	921	281	3
	722	220	4
	594	181	5
	504	154	6
	438	134	7
	388	118	8

Vs = 12V RPM 88 Requires external supply	1000	305	1
	795	242	2
	576	176	3
	451	138	4
	371	113	5
	315	96	6
	274	84	7
	242	74	8

Vs = 8V	256	78	1
	159	48	2
	115	35	3
	90	28	4
	74	23	5
	63	19	6
	55	17	7
	48	15	8

Note: This table is *only* for systems using SR 2 remotes (all remotes on 485 bus are the same). For mix and match calculation of SR 2, SR 3 and SR 4 Remotes, use the SRCABLELENGTH.XLS Microsoft Excel™ spreadsheet on the Drag Net CD-ROM or at www.rane.com/sr2.html.

Cable Type 1

Multiple run restriction (per table entries): $d1 \leq 921$ ft, $d2 \leq 1,000$ ft, $d3 \leq 1,000$ ft
 Total cable length must be under 1,000 ft: $d1 + d2 + d3 = dT \leq 1,000$ ft

RPM REMOTE INTERFACE PORT



BELDEN #1588 (A/R)
 BELDEN #1590 (A)

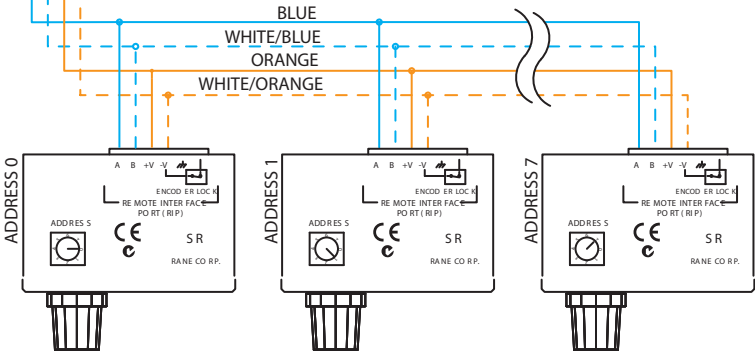

Examples:

So if

$d1=400$ ft (<921 ft, OK)

$d2=300$ ft ($<1,000$ ft, OK)

$d3=200$ ft ($<1,000$ ft, OK)

$d1+d2+d3=900$ ft, then it's all OK!

but if

$d1=400$ ft (<921 ft, OK)

$d2=500$ ft ($<1,000$ ft, OK)

$d3=300$ ft ($<1,000$ ft, OK)

$d1+d2+d3=1,200$ ft, then it's NOT OK!

Cable Type 2

4 twisted pair unshielded CAT 5, Belden #1583(A, B, E, ENH, R)

4 twisted pair shielded CAT 5, Belden #1624 (P, R)

4 twisted pair unshielded CAT 5, Belden #1700 (A, R)

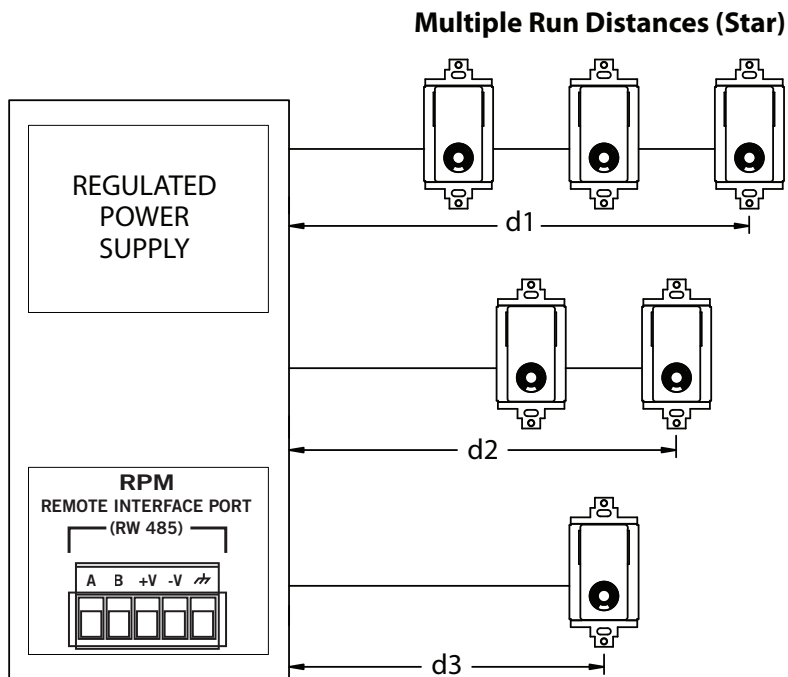
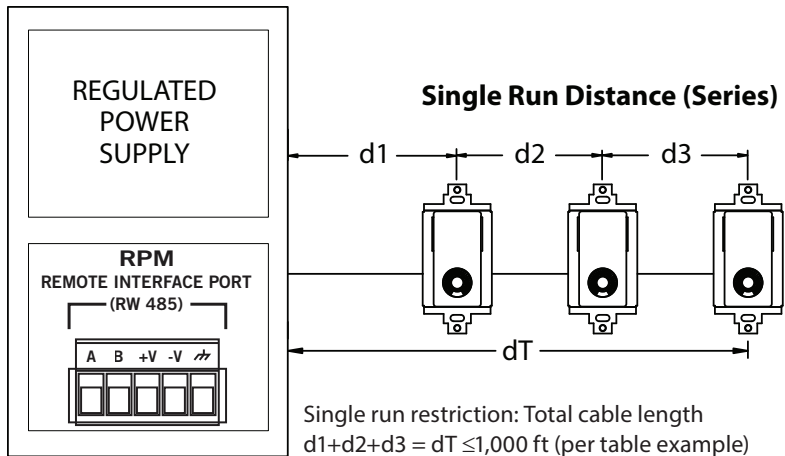

Cable Type 2

4 twisted pair unshielded CAT 5, Belden #1583(A, B, E, ENH, R)

4 twisted pair shielded CAT 5, Belden #1624 (P, R)

4 twisted pair unshielded CAT 5, Belden #1700 (A, R)

	Max Distance for Cable (feet)	Max Distance for Cable (meters)	Number of SR 2 Remotes
Vs = 12V RPM 44 RPM 22	1000	305	1
	1000	305	2
	1000	305	3
	1000	305	4
	1000	305	5
	1000	305	6
	1000	305	7
	1000	305	8

Vs = 12V RPM 88 Requires external supply	1000	305	1
	1000	305	2
	1000	305	3
	1000	305	4
	1000	305	5
	946	288	6
	822	251	7
	727	222	8

Vs = 8V	769	235	1
	477	145	2
	345	105	3
	271	83	4
	223	68	5
	189	58	6
	164	50	7
	145	44	8

Note: This table is **only** for systems using SR 2 remotes (all remotes on 485 bus are the same). For mix and match calculation of SR 2, SR 3 and SR 4 Remotes, use the SRCABLELENGTH.XLS Microsoft Excel™ spreadsheet on the Drag Net CD-ROM or at www.rane.com/sr2.html.

Cable Type 2

More conductors mean greater operating distance.

Multiple run restriction (per table entries): $d_1 \leq 1,000$ ft, $d_2 \leq 1,000$ ft, $d_3 \leq 1,000$ ft

Total cable length must be under 1,000 ft: $d_1 + d_2 + d_3 = d_T \leq 1,000$ ft

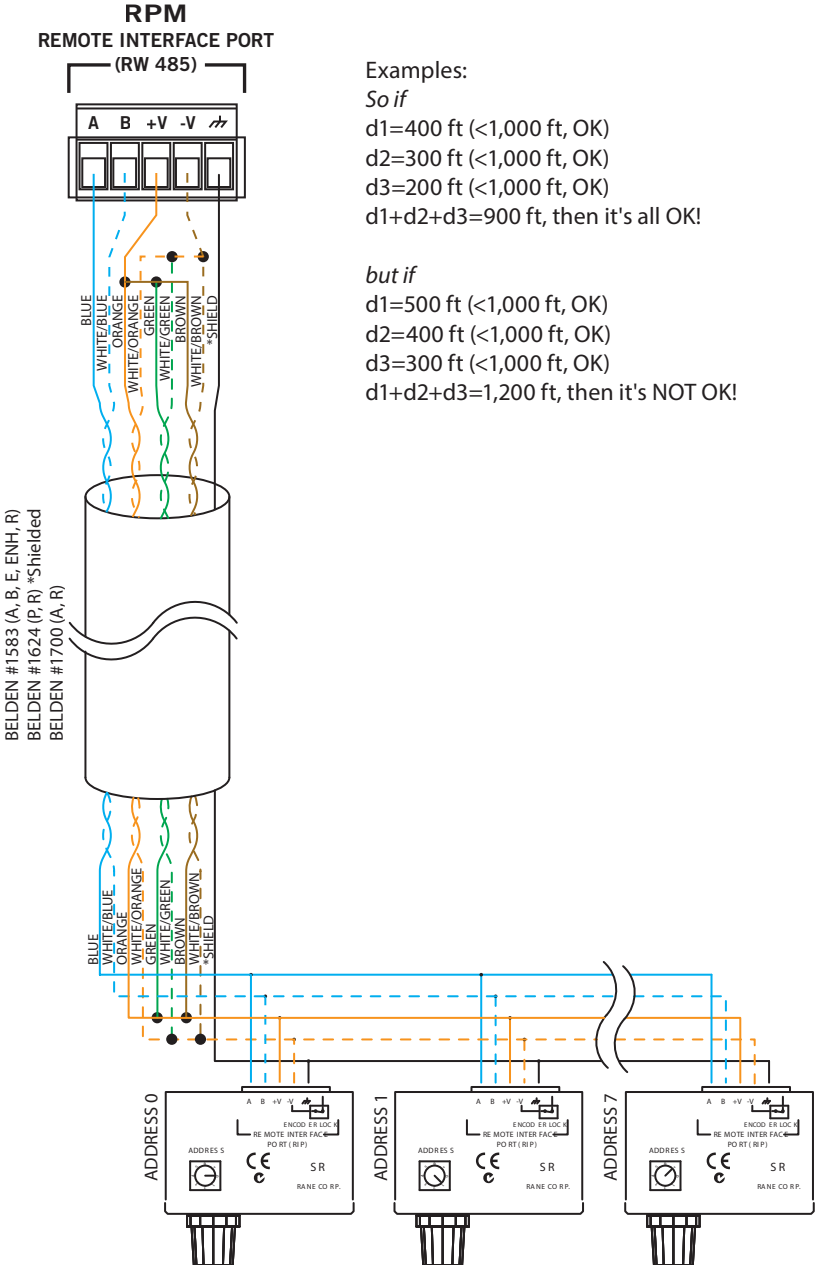

SR 2 Communication Protocol

The SR 2 communication protocol follows Rane's RW 485 specification. The following describes the SR 2 implementation.

Physical

The baud rate is 38,400 bps with No parity, 8 Data Bits, 1 Stop Bit (N81) format. The SR 2 also supports 9600, 19200, 57600, and 115200 bps. When configuring Remotes used with Rane controllers (RPM 22, 44, 88), the RW 485 baud rate of 38400 bps is required. At the end of a command message, the Master must release the bus within 10 ms. The SR 2 waits this length of time before transmitting its response. To restore the SR 2 communication settings to 38400 baud 10 ms delay, apply power while pushing the encoder *in* for several seconds until the encoder LED illuminates.

Master/Slave

RW 485 is a master/slave bus network, with only one master in charge, which we define as the Protocol Master (controller). When the Protocol Master expects a response from a slave, it relinquishes control of the bus, allowing the slave to drive the RS-485 bus. The slave must then release the bus back to the Protocol Master, and we start again. The SR 2 is always a slave.

Value Encoding

All numeric values are represented in ASCII decimal format separated by commas. Values with the MSB set (\$80 or larger) are interpreted as potential device addresses.

Syntax

Command messages are sent from the Protocol Master to the SR 2. Response messages are returned to the Protocol Master from the SR 2.

The SR 2 always responds to the Protocol Master upon receiving a complete command message at the correct baud rate.

Command and response messages have the same format:

message = <addr> <msgtype> <devtype> <checksum> <command/data> <CR>

<addr> Each device has a unique address in the range [0, 7]. The encoding is one byte with the MSB set.

For example, if the SR 2's address switch is set to 5, the controller would send 10000101. (\$5 + \$80)

The SR 2 always returns its address switch setting plus \$80. (\$addr + \$80)

The address switch must be set in the range [0, 7].

<msgtype> The msgtype is a one byte set of flags indicating options, bit 7=MSB:

- bit 0) set = checksum is valid
- bit 1) set = there has been an error (response only)
- bit 2-5) reserved, cleared to 0
- bit 6) always 1
- bit 7) always 0

If the controller wants the SR 2 to verify the checksum, it would send a value of \$41, or an ASCII 'A'. If the controller wants the SR 2 to ignore the checksum, it would send a value of \$40, or an ASCII '@'.

The SR 2 echoes back the **<msgtype>** it was sent. In the case of an error, the SR 2 sets bit 1.

<devtype> The SR 2 device type value is \$32, or an ASCII '2'. The SR 2 also accepts a value of \$30, or an ASCII '0', the universal device type used for polling.

The SR 2 always returns its device type of \$32.

<checksum> The checksum is defined as the sum of the ASCII encoded values of the **<command/data>** section. The sum is then masked with \$007F to produce one byte with the MSB set to zero.

The controller would send a valid checksum as defined above if it sent a value of \$41 for the **<msgtype>**. The SR 2 then verifies the sent checksum by calculating the checksum from the data it received in the **<command/data>** section of the sent message. On the other hand, if the controller sent a value of \$40 for the **<msgtype>** the SR 2 ignores the sent checksum. The controller must always send a checksum less than or equal to \$7F, even if it intends for the SR 2 to ignore it.

The SR 2 **<checksum>** response is based on the **<msgtype>** it was sent. If the SR 2 received a **<msgtype>** of \$41, it returns a valid checksum (as defined) calculated from its response data. If the SR 2 received a **<msgtype>** of \$40, it returns zero.

<command/data> The general format is <cmd1,arg1,arg2,...,cmd2,arg1,...>. The commas are part of the **<command/data>** structure and act as delimiters between the ASCII encoded commands and data. Concatenation of commands is limited to four commands. Text string arguments are delimited with quotes ("String"). If the string argument contains quotes, an accent character (') placed in the string argument will be interpreted by the SR 2 as a double quote character ("). The ASCII value for the accent character is \$60, not to be confused with a single quote character ('), ASCII value \$27. For example: string argument: "A string that contains 'quotes' " is interpreted as: A string that contains "quotes".

The controller sends commands/arguments for the SR 2 to process. This section of the message is limited to 40 characters for the SR 2. See the SR 2 Command Set section for details of valid commands.

The SR 2 responds with response data based on the commands/arguments it was sent. The SR 2 limits its response data to 40 characters. In the case of an error, the response data is: n,"ERROR" where n is an error code defined below:

Hex	ASCII	Error Code Meaning
\$31	'1'	Sent <devtype> invalid.
\$32	'2'	Sent <checksum> did not verify.
\$33	'3'	Sent <command/data> parse error.
\$34	'4'	Sent <command/data> greater than 40 characters, or the number of concatenated commands >4.
\$35	'5'	Response <command/data> greater than 40 characters.

See the **SR 2 Command Set** section below for details of valid SR 2 responses.

<CR> A carriage return (\$0D) terminates every message.

SR 2 Command Set

This section details the <command/data> portion of a complete RW 485 message. The SR 2 supports 10 commands. Below is a table of commands and associated responses, followed by descriptions.

Configuration Commands

Cmd	Arg(s)*	Description	Response**
V		Get Firmware, Hardware Version	n1,n2,"OK"
N	["ccc..."]	Read/Write Device's Name	"ccc...","OK"
SPL	n1[,n2]	Read/Write Stored Parameter	n,"OK"

Input Commands

ILD	[n1]	Read/Write LED Enable	n1,"OK"
ILK	[n1]	Read/Write Input Lock	n1,"OK"
IQ		Input Query	n1,n2,"OK"
IR		Input Raw	n1,n2,n3,n4,"OK"
IS	n1,n2	Input Suggest	n1,n2,"OK"
ISR	n1,n2	Input Suggest Raw	n1,n2,n3,n4,"OK"
IF	n1,n2	Input Force	"OK"

* [] denotes optional Command Argument

** Responses from concatenated commands produce only one "OK"

Configuration Commands

V

Get Firmware, Hardware Version

Send: V

Response: n1,n2,"OK"

Where: n1 is a two digit ASCII encoded decimal value representation of the firmware version. The first digit is the major firmware version and the second digit is the minor firmware version.
n2 is a one digit ASCII encoded decimal value representation of the hardware version.

Example: 13,2,"OK" means firmware version 1.3, hardware version 2.

N

Read/Write Device's Name

The device's name is limited to 32 characters and is stored in non-volatile memory. The default name is SR 2.

To read the device's name:

Send: N

Response: "ccc","OK"

Where: ccc is the device's name.

Example: "SR 2","OK" means the device's name is SR 2.

To write a new name to the device:

Send: N,"ccc"

Where: ccc is the new name.

Example: N,"Conference Room 101" will rename the device to Conference Room 101

Response: "OK"

SPL

Read/Write Stored Parameter

Various configuration parameters are stored in non-volatile memory. This command reads and writes these parameters. For details of each parameter, see the **Stored Parameter List** section following the **Command Set** section.

To read a stored parameter value:

Send: SPL,n1

Where: n1 is the stored parameter index.

Example: SPL, 1 indexes the first parameter in the list which is the Auto Level parameter.

Response: n1,"OK"

Where: n1 is the value of the indexed parameter.

Example: 1,"OK" means that Auto Level is enabled.

To write a stored parameter value:

Send: SPL,n1,n2

Where: n1 is the stored parameter index.

n2 is the value to be stored.

Example: SPL,1,0 sets Auto Level parameter to 0, disabling the Auto Level function.

Response: "OK"

Encoder Input Commands

ILD

Read/Write LED Enable byte

Reads or writes the LED Enable byte. The format of the LED Enable byte is as follows: bit 0 set enables LED indication of the main level, bit 1 set enables the LED indication of the second level (only applicable when Auto Second Level is enabled and the encoder is pushed in). This LED Enable is volatile, meaning upon power-up of the device the LED Enable byte is always set to 3 enabling both main and second level LED indication.

To read the LED Enable byte:

Send: ILD

Response: n1,"OK"

Where: n1 is the LED Enable byte. The range is [0, 3].

Example: 1,"OK" means that the main level LED indication is enabled and the second level LED indication is disabled.

To write the LED Enable byte:

Send: ILD,n1

Where: n1 is the LED Enable byte. The range is [0, 3].

Example: ILD,0 disables both main and second level LED indication.

Response: "OK"

ILK

Read/Write Software Input Lock

Reads or writes the input encoder software lock byte. The format of the lock byte is as follows: bit 0 set locks the main level (no action when encoder is turned), bit 1 set locks the second level (no action when the encoder is pushed in and turned), bit 2 set locks the enter state (no enter command state change when the encoder is pushed and released without turning). This lock byte is volatile, meaning upon power up of the device the software lock byte is always cleared to zero.

To read the Software Input Lock byte:

Send: ILK

Response: n1,"OK"

Where: n1 is the Software Input Lock byte. The lock byte range is [0, 7].

Example: 3,"OK" means that both the main level and second level are locked.

To write the Software Input Lock status:

Send: ILK,n1

Where: n1 is the Software Input Lock byte. The lock byte range is [0, 7].

Example: ILK,2 locks the second level.

Response: "OK"

IQ

Input Query

Returns the current main level and second level. Resets the command state to No Operation.

Send: IQ

Response: n1,n2,"OK"

Where: n1 is the current main level. The main level range is [1, 31].

n2 is the current second level. The second level range is [1, 31].

Example: 15,4, "OK" means that the current main level is 15 and the current second level is 4.

IR

Input Raw

Returns the current level, second level, command state, and the length of time the encoder button has been pressed.

Resets the command state to No Operation.

Send: IR

Response: n1,n2,n3,n4,"OK"

Where: n1 is the current main level. The main level range is [1, 31].

n2 is the current second level. The second level range is [1, 31].

n3 is the current command state. The command state represents the state of the encoder.

The possible states follow:

- | | | |
|----|-----------------|---|
| 0 | No Operation | The encoder has not changed. |
| 1 | Encoder Left | The encoder has been turned counter clockwise. |
| 2 | Encoder Right | The encoder has been turned clockwise |
| 16 | Selection Left | The encoder has been pushed in and turned counter clockwise. |
| 32 | Selection Right | The encoder has been pushed in and turned clockwise. |
| 64 | Enter | The encoder has been pushed in and released without being turned. |

n4 is the length of time the encoder button has been pressed. The time the button has been pressed is in units of .01 seconds and the range is [0, 255] or 0 to 2.55 seconds. The button timer starts at the press of the button and is reset to zero when the button is released.

Example: 1,2,32,100,"OK" means the current main level is 1, the current second level is 2, the current command state byte is a Second Level Right and the button has been held in for 1 second.

IS

Input Suggest

Suggests new main level and second level. Resets the command state to No Operation. If Auto Level is enabled, the main level is updated and indicated by the LED only if the device's main level has not changed by someone turning the encoder. Otherwise, if Auto Level is disabled, the main level is updated and indicated by the LED regardless of encoder input.

If Auto Second Level is enabled, the second level is updated and indicated by the flashing LED only if the device's second level has not changed by someone pushing in and turning the encoder. Otherwise, if Auto Second Level is disabled, the second level is updated regardless of encoder input.

Send: IS,n1,n2

Where: n1 is the suggested new main level. The main level range is [0, 31]. If n1 is zero, the main level remains unchanged.

n2 is the suggested new second level. The second level range is [0, 31]. If n2 is zero, the second level remains unchanged.

Example: IS,3,5 suggests a new main level of 3 and a new second level of 5.

Response: n1,n2,"OK"

Where: n1 is the current main level. The main level range is [1, 31].

n2 is the current second level. The second level range is [1, 31].

Example: 3,5,"OK" means that the current main level is 3 and the current second level is 5. This means the suggested main level and second level were updated. A response of 10,5,"OK" means the current main level is 10 and was last changed by someone turning the encoder and the current second level was updated to 5.

ISR

Input Suggest Raw

Same operation as IS Input Suggest except ISR returns the command state byte and button time. Suggests new main level and second level.

Resets the command state to No Operation.

If Auto Level is enabled, the main level is updated and indicated by the LED only if the device's main level has not changed by someone turning the encoder. Otherwise, if Auto Level is disabled, the main level is updated and indicated by the LED regardless of encoder input.

If Auto Second Level is enabled, the second level is updated and indicated by the flashing LED only if the device's second level has not changed by someone pushing in and turning the encoder. Otherwise, if Auto Second Level is disabled, the second level is updated regardless of encoder input.

Send: ISR,n1,n2

Where: n1 is the suggested new main level. The main level range is [0, 31]. If n1 is zero, the main level remains unchanged.

n2 is the suggested new second level. The second level range is [0, 31]. If n2 is zero, the second level remains unchanged.

Example: ISR,3,5 suggests a new main level of 3 and a new second level of 5.

Response: n1,n2,n3,n4,"OK"

Where: n1 is the current main level. The main level range is [1, 31].

n2 is the current second level. The second level range is [1, 31].

n3 is the current command state. The command state represents the state of the encoder.

The possible states follow:

- | | | |
|----|-----------------|---|
| 0 | No Operation | The encoder has not changed. |
| 1 | Encoder Left | The encoder has been turned counter clockwise. |
| 2 | Encoder Right | The encoder has been turned clockwise. |
| 16 | Selection Left | The encoder has been pushed in and turned counter clockwise. |
| 32 | Selection Right | The encoder has been pushed in and turned clockwise. |
| 64 | Enter | The encoder has been pushed in and released without being turned. |

n4 is the length of time the encoder button has been pressed. The time the button has been pressed is in units of .01 seconds and the range is [0, 255] or 0 to 2.55 seconds. The button timer starts at the press of the button and is reset to zero when the button is released.

Example: 3,5,0,0,"OK" means the current main level is 3, the current second level is 5, the current command state byte is a No Operation and the button is not pushed in. This means the main level and second level were updated. A response of 3,7,32,100,"OK" means the current main level was updated to 3, the current second level is 7 and was last changed by someone pushing in and turning the encoder, the current command state byte is a Second Level Right, and a non-zero button time means someone is still holding the button in.

IF

Input Force

Forces new main level and second level. Resets the command state to No Operation. The main level is updated and indicated by the LED regardless of Auto Level configuration.

If Auto Second Level is enabled, the second level is updated and indicated by the flashing LED. Otherwise, if Auto Second Level is disabled, the second level is updated.

Send: IF,n1,n2

Where: n1 is the new main level. The main level range is [0, 31].

If n1 is zero, the main level remains unchanged.

n2 is the new second level. The second level range is [0, 31]. If n2 is zero, the second level remains unchanged.

Example: IF,3,5 sets a new main level of 3 and a new second level of 5.

Response: "OK"

Stored Parameter List (SPL)

Below is a table of stored parameters followed by descriptions of each parameter.

Index	Description	Values	Setting	Meaning
1	Auto Level	0 - 1	1	disabled - enabled
2	Auto Second Level	0 - 1	1	disabled - enabled
3	Auto Lock	0 - 1	1	disabled - enabled
4	Baud Rate	0 - 4	2	0 = 9600, 1 = 19200, 2 = 38400, 3 = 57600, 4 = 115200
5	RW 485 Transmit Delay (ms)	2 - 200	10	2 - 200 ms

Parameter Descriptions

1. Auto Level configuration affects the result of turning the encoder. Turning the encoder without pushing it in updates the command state to an Encoder Left for a counter clockwise turn or an Encoder Right for a clockwise turn unless the device is locked. If Auto Level is enabled (a value of 1), the main level is updated and indicated by the LED as well. The Auto Level configuration also affects the Encoder Input Commands **IS** and **ISR**. See **Encoder Input Commands** section for details of how these commands are affected.
2. Auto Second Level configuration affects the result of turning the encoder while it is pushed in. Turning the encoder while pushing it in updates the command state to a Second Level Left for a counter clockwise turn or a Second Level Right for a clockwise turn unless the device is locked. If Auto Second Level is enabled (a value of 1), the second level is updated and indicated by a flashing LED as well. The flashing LED is only visible when the encoder is pushed in. The Auto Second Level configuration also affects the Encoder Input Commands **IS**, **ISR**, and **IF**. See **Encoder Input Commands** section for details of how these commands are affected.
3. Auto Lock configuration affects the operation of the device when the lock input is shorted to -V. If the device is configured for Auto Lock (a value of 1) and the Lock input is shorted to -V, the encoder is locked out regardless of the software lock status (see ILK command on page Manual-13). If the device is not configured for Auto Lock (a value of 0), the Lock input is ignored and the encoder's lock state is defined by the software lock status.
4. This parameter sets the baud rate of the device. When this parameter is changed via a RW 485 message, the response is sent at the current baud rate, then the baud rate is updated to the new baud rate specified by the value sent. The default setting of 38400 is required for use with Rane controllers (i.e., RPM 88/44/22). It can be restored by holding the encoder in during power-up for several seconds until the encoder LED turns on.
5. This parameter sets the minimum time in milliseconds the remote waits after receiving a RW 485 message before it transmits a response. It is recommended that this value not be changed. The default setting can be restored by holding the encoder in during power-up for several seconds until the encoder LED turns on.

Smart Remote Specifications

Parameter	Specification	
I/O: Type	RS-485	
.....Impedance	12k	
.....Baud Rate	38400	
	9600	
	19200	
	57600	
	115200	
.....Data Format	N81	
Power Supply Requirement	7 minimum, 16 maximum	
RW 485 Drive Current	28	
SR 4: Supply Current	52	
SR 3: Supply Current	50	
	95	
SR 2: Supply Current	42	
All Units: Agency Listing	CE (EMC)	
	CE (safety) Exempt	
.....Construction	Steel	
	Polycarbonate	
SR 2 / SR 4: Size	4.1" H x 1.7" W x 2.8" D	
SR 3: Size	4.1" H x 1.9" W x 2.8" D	
All Units: Weight	8 oz	
.....Shipping: Size	3.6" H x 11.75" W x 7.2" D	
.....Weight	1 lb 8 oz	

	Limit	Units	Conditions/Comments
			Euroblock connector
	min	Ω	Receive Mode
	<1%	bps	RW 485 baud rate
	<1%	bps	Programmable
	<1%	bps	Programmable
	<1%	bps	Programmable
	<1%	bps	Programmable
			No parity, 8 data bits, 1 stop bit
	min	VDC	DC voltage @ +V referenced to -V
	+1	mA	No termination, communication active. One remote per bus active at a time.
	+5	mA	Communication idle
	+5	mA	Backlight off, communication idle
	+5	mA	Backlight max brightness, communication idle
	+4	mA	Communication idle
			EMC directive 89/336/EEC
			Exempt per article 1, LVD 73/23/EEC
			Chassis
			Lens
			(10.4 cm x 4.3 cm x 7.1 cm)
			(10.4 cm x 4.8 cm x 7.1 cm)
			(.23 kg)
			(9.2 cm x 30 cm x 18 cm)
			(.69 kg)



Factory Authorized Service

Your unit may be serviced by the Rane Factory or any Authorized Rane Service Center. To find a Service Center near you, please call the Rane factory, or check the Rane website. Please do not return your unit to Rane without prior authorization.

Rane Corporation

To obtain service or a Return Authorization, please phone 425-355-6000
or Fax 425-347-7757

The current list of U.S. Rane Authorized Service Centers is on our website:

www.rane.com/service.html

Limited Domestic Warranty

RANE CORPORATION WARRANTS ALL RANE PRODUCTS (EXCEPT THOSE ITEMS CLASSIFIED AS *WEAR PARTS*, AND LISTED ON THE FIRST PAGE OF EACH OPERATORS MANUAL) PURCHASED IN THE U.S. AGAINST DEFECTS IN MATERIAL OR WORKMANSHIP FOR A PERIOD OF TWO (2) YEARS. *WEAR PARTS* ARE LIMITED TO A PERIOD OF NINETY (90) DAYS FROM THE INITIAL DATE OF RETAIL PURCHASE FROM AN AUTHORIZED RANE DEALER—WEAR PARTS REQUIRE PROOF OF PURCHASE DATE. This limited warranty extends to all purchasers or owners of the product during the warranty period beginning with the original retail purchase. Rane Corporation does not, however, warrant its products against any and all defects: 1) arising out of material or workmanship not provided or furnished by Rane, or 2) resulting from abnormal use of the product or use in violation of instructions, or 3) in products repaired or serviced by other than authorized Rane repair facilities, or 4) in products with removed or defaced serial numbers, or 5) in components or parts or products expressly warranted by another manufacturer. Rane agrees to supply all parts and labor to repair or replace defects covered by this limited warranty with parts or products of original or improved design, at its option in each respect, if the defective product is shipped prior to the end of the warranty period to any Rane authorized warranty repair facility in the U.S. or to the Rane factory in the original packaging or a replacement supplied by Rane, with all transportation costs and full insurance paid each way by the purchaser or owner.

LIMITED WARRANTY OUTSIDE THE U.S.A.

RANE PRODUCTS ARE WARRANTED ONLY IN THE COUNTRY WHERE PURCHASED, THROUGH THE AUTHORIZED RANE DISTRIBUTOR IN THAT COUNTRY, AGAINST DEFECTS IN MATERIAL OR WORKMANSHIP, THE SPECIFIC PERIOD OF THIS LIMITED WARRANTY SHALL BE THAT WHICH IS DESCRIBED TO THE ORIGINAL RETAIL PURCHASER BY THE AUTHORIZED RANE DEALER OR DISTRIBUTOR AT THE TIME OF PURCHASE. Rane Corporation does not, however, warrant its products against any and all defects: 1) arising out of materials or workmanship not provided or furnished by Rane, or 2) resulting from abnormal use of the product or use in violation of instructions, or 3) in products repaired or serviced by other than authorized Rane repair facilities, or 4) in products with removed or defaced serial numbers, or 5) in components or parts or products expressly warranted by another manufacturer. Rane agrees, through the applicable authorized distributor, to repair or replace defects covered by this limited warranty with parts or products of original or improved design, at its option in each respect, if the defective product is shipped prior to the end of the warranty period to the designated authorized Rane warranty repair facility in the country where purchased, or to the Rane factory in the U.S., in the original packaging or a replacement supplied by Rane, with all transportation costs and full insurance paid each way by the purchaser or owner.

ALL REMEDIES AND THE MEASURE OF DAMAGES ARE LIMITED TO THE ABOVE SERVICES, IT IS POSSIBLE THAT ECONOMIC LOSS OR INJURY TO PERSON OR PROPERTY MAY RESULT FROM THE FAILURE OF THE PRODUCT; HOWEVER, EVEN IF RANE HAS BEEN ADVISED OF THIS POSSIBILITY, THIS LIMITED WARRANTY DOES NOT COVER ANY SUCH CONSEQUENTIAL OR INCIDENTAL DAMAGES. SOME STATES OR COUNTRIES DO NOT ALLOW THE LIMITATIONS OR EXCLUSION OF INCIDENTAL OR CONSEQUENTIAL DAMAGES, SO THE ABOVE LIMITATION MAY NOT APPLY TO YOU.

ANY AND ALL WARRANTIES, EXPRESS OR IMPLIED, ARISING BY LAW, COURSE OF DEALING, COURSE OF PERFORMANCE, USAGE OF TRADE, OR OTHERWISE, INCLUDING BUT NOT LIMITED TO IMPLIED WARRANTIES OF MERCHANTABILITY AND FITNESS FOR A PARTICULAR PURPOSE, ARE LIMITED TO A PERIOD OF TWO (2) YEARS FROM EITHER THE DATE OF ORIGINAL RETAIL PURCHASE OR, IN THE EVENT NO PROOF OF PURCHASE DATE IS AVAILABLE, THE DATE OF MANUFACTURE, SOME STATES OR COUNTRIES DO NOT ALLOW LIMITATIONS ON HOW LONG AN IMPLIED WARRANTY LASTS, SO THE ABOVE LIMITATIONS MAY NOT APPLY TO YOU. THIS LIMITED WARRANTY GIVES YOU SPECIFIC LEGAL RIGHTS, AND YOU MAY ALSO HAVE OTHER RIGHTS WHICH VARY FROM STATE TO STATE, COUNTRY TO COUNTRY.

Warranty Procedure - Valid in USA only

NOTICE! You must complete and return the warranty card or register your product online to extend the Warranty from 2 years to 3 years!

TO VALIDATE YOUR EXTENDED WARRANTY

Use the postcard that came in the box with your unit, or go to www.rane.com and click on **New Product Registration**. Fill out the warranty completely, being sure to include the model and serial number of the unit since this is how warranties are tracked. If your Rane product was purchased in the U.S.A., mail the completed card or register online with to Rane Corporation within 10 days from the date of purchase. **If you purchased the product outside the U.S.A. you must file your warranty registration with the Rane Distributor in that country.** It is advised that you keep your bill of sale as proof of purchase, should any difficulties arise concerning the registration of the warranty card. **NOTICE: It is not necessary to register in order to receive Rane Corporation's standard two-year limited warranty.**

WARRANTY REGISTRATION is made and tracked by **model and serial numbers only**, not by the purchaser's or owner's name. Therefore any warranty correspondence or inquires **must** include the model and serial number of the product in question. Be sure to fill in the model and serial number in the space provided below and keep this in a safe place for future reference.

WARRANTY SERVICE MUST BE PERFORMED ONLY BY AN AUTHORIZED RANE SERVICE FACILITY LOCATED IN THE COUNTRY WHERE THE UNIT WAS PURCHASED, OR (if product was purchased in the U.S.) AT THE RANE FACTORY IN THE USA. If the product is being sent to Rane for repair, please call the factory for a Return Authorization number. We recommend advance notice be given to the repair facility to avoid possible needless shipment in case the problem can be solved over the phone.

UNAUTHORIZED SERVICE PERFORMED ON ANY RANE PRODUCT WILL VOID ITS EXISTING FACTORY WARRANTY.

FACTORY SERVICE

If you wish your Rane product to be serviced at the factory, **it must be shipped fully insured, in the original packing box or equivalent.** This warranty will **not** cover repairs on products damaged through improper packaging. If possible, avoid sending products through the U.S. mail. Be sure to include in the package:

1. Complete return street shipping address (P.O. Box numbers are **not** acceptable).
2. A detailed description of any problems experienced, including the make and model numbers of any other system equipment.
3. Remote power supply, if applicable.

Repaired products purchased in the U.S. will be returned prepaid freight via the same method they were sent to Rane. Products purchased in the U.S., but sent to the factory from outside the U.S. **must** include return freight funds, and the sender is fully responsible for all customs procedures, duties, tariffs and deposits.

In order to qualify for Rane's one year extended warranty (for a total of 3 years parts and labor), the warranty must be completely filled out and sent to us immediately. Valid in the USA only.

We recommend you write your serial number here in your owners manual and on your sales receipt for your records.

SERIAL NUMBER: _____

PURCHASE DATE: _____

©Rane Corporation 10802 47th Ave. W., Mukilteo WA 98275-5000 TEL 425-355-6000 FAX 425-347-7757 WEB www.rane.com

Declaration of Conformity

**Application of
Council directive(s):**

73/23/EEC
89/336/EEC

**Standard(s) to which
conformity is declared:**

EN60065:1998
EN55103-1:1996
EN55103-2:1996
ENVIRONMENT E2
COMMERCIAL AND
LIGHT INDUSTRIAL

Manufacturer:

Rane Corporation
10802 47th Avenue West
Mukilteo WA 98275-5098 USA

This equipment has been tested and found to be in compliance with all applicable standards and regulations applying to the EU's Low Voltage (LV) directive 73/23/EEC, and Electromagnetic Compatibility (EMC) directive 89/336/EEC. In order for the customer to maintain compliance with this regulation, high quality shielded cable must be used for interconnection to other equipment. Modification of the equipment, other than that expressly outlined by the manufacturer, is not allowed under this directive. The user of this equipment shall accept full responsibility for compliance with the LV directive and EMC directive in the event that the equipment is modified without written consent of the manufacturer.

Manufacturer: Rane Corporation

Type of Equipment: Professional Audio Signal Processing

Models: SR 2, SR 3, SR 4

Immunity Results:
No susceptibilities observed.

I, the undersigned, hereby declare that the equipment specified above conforms to the Directive(s) and Standard(s) shown above.



(Signature)

Roy G. Gill

(Full Name)

Compliance Engineer

(Position)

November 1, 2001

(Date)

Mukilteo WA USA

(Place)



SR 2

SMART REMOTE

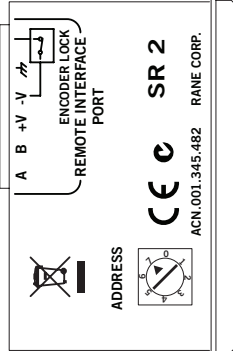
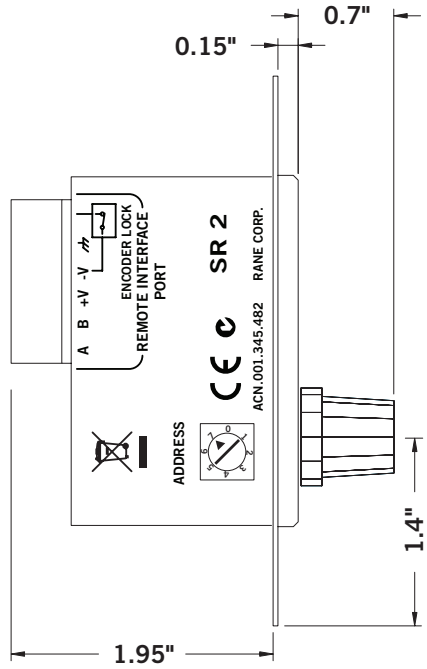
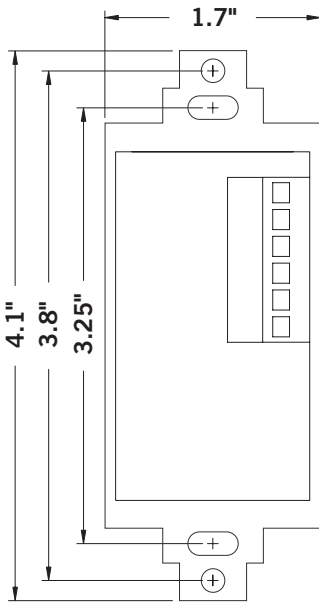

Rane part 14332

