

# Rane Sixty-Eight Mixer for Serato DJ

Two computers, two USB ports, four decks, eight selectable inputs, software controls and a range of effects make the Sixty-Eight Rane's biggest mixer.

Using two USB ports, the Sixty-Eight lets two DJs use their laptops at the same time, allowing seamless handover between DJs. You can also control up to four decks with a single laptop.

Armed with studio-grade phono preamps, USB and S/PDIF deck inputs, along with even more analog inputs, the Sixty-Eight blends a wide selection of analog and digital audio sources. It features easy internal digital effects with on-beat effect switching, external analog inserts for hardware effects, and USB insert support for software effects.



#### • Input Channels:

- Four stereo inputs, individually switchable to Phono, Line or S/PDIF.
- Four stereo Auxiliary Line inputs.
- Four stereo USB playback options.
- Two independent USB 2.0 high speed ports:
  - Each supports twenty-two 32-bit audio channels at 48 kHz.
- Direct control of over 30 Library, Cue and Loop functions.
- Support for two, three or four Virtual Decks in Serato DJ. Serato Scratch Live, or other audio programs with Core Audio or ASIO support.
- Flexible USB recording from any input or output.
- 3-band, full-cut EQ with a sweepable High / Low pass Filter.
- Unique FlexFX bus with six internal effects, plus analog effects insert and USB support for software-based effects.
- Two independent mic inputs:
  - One has +48 volt phantom power.
  - One has a line-level input switch for wireless.
- Unit size: 14.3"H x 12"W x 4"D (36.4 x 30.5 x 10.2 cm)



serato DJ

RANE

The Sixty-Eight includes Serato DJ with 4 Serato Control Vinyl and 4 Serato Control CDs.

# Sixty-Eight Mixer Controls

Mic 1 allows +48 volt switchable phantom power. Mic 2 allows switchable Mic or Line-level input. Both Mics have 2-band full-cut tone controls. Either Mic can route to FlexFX or record to USB.

Four Program buses, each includes:

- Four Phono - Line - S/PDIF Inputs.
- Four Aux Line Inputs.
- Four USB playback Inputs.

Two USB ports, each with six stereo record channels and five stereo playback channels simultaneously available, allows two DJs with their own laptops to share the mixer.

The outer strips directly control Serato Scratch Live functions such as Cue Points, Loops, Track Library, and recalling custom Groups.

In Auto mode, Loop buttons use the Scratch Live auto-loop, lighting the buttons green. In Manual mode, Loop buttons use manual looping features, lighting the buttons orange. Select knob adjusts the loop length.

FlexFX are stackable:

- Six internal effects with seamless on-beat switching between effects.
- External Insert engages the external analog Effects Loop.
- ↔ 5 Insert engages software effects through USB.

Recall Cue Points with "Hot Cue" behavior supported in Scratch Live.



The Control Point button selects the USB port in control of the control strips.

Back buttons shift between crates & tracks. Scroll knob scrolls crates & tracks, click it to load the track to a deck.

Program buses include 3-band full-cut tone controls plus sweepable Low-pass / High-pass cut filters.

Level controls on each Output:

- Main Output on XLR jacks
- Booth Output on 1/4" TRS
- Session Output on RCA

True Split Cue for any Program bus or the FlexFX submix with effects to the front panel 1/4" and 3.5 mm headphone jacks.

The FlexFx Loop can create a sub-mix with any combination of the four Program buses and two Mics, and then add internal or external effects. This submix may be recorded via the USB Send, or output by the analog FlexFx Loop Send.

Controls the level of the FlexFx signal to the Main Mix.

Supports 2, 3 or 4 Virtual Decks in Serato Scratch Live on one or two computers.

Contour controls adjust faders and the Crossfader for a smooth transition or a fast cut.

The Crossfader is a no-noise, no-bleed magnetic fader.

Record to USB from any Program bus, any Mic or the Main Output.

## Mounting Ears Accessories

The optional 14" EARS kit is available for securing the mixer in a coffin, and the optional 19" EARS kit mounts the Sixty-Eight in a 19" rack. Both are made from the same metal and finish as the Sixty-Eight Mixer.

# Sixty-Eight Effects

## FlexFx

The FlexFx Bus in the Sixty-Eight works differently than other basic effect insert solutions. The FlexFx Bus is more like an auxiliary bus that can have multiple signals assigned to it. Those combined signals can have internal effects, external analog effects and external USB effects applied in any combination. It is possible to cue and control the level of this auxiliary mix in the Main Mix. This architecture is very flexible and not at all like simply inserting an effect in a signal path and turning it on.

The order of processing in the FlexFx Bus is:

1. FlexFx assign for each PGM and Mic.
2. Internal Effects
3. External Analog Insert
4. USB Insert
5. Cue
6. FlexFx On
7. FlexFx Mix Level control.

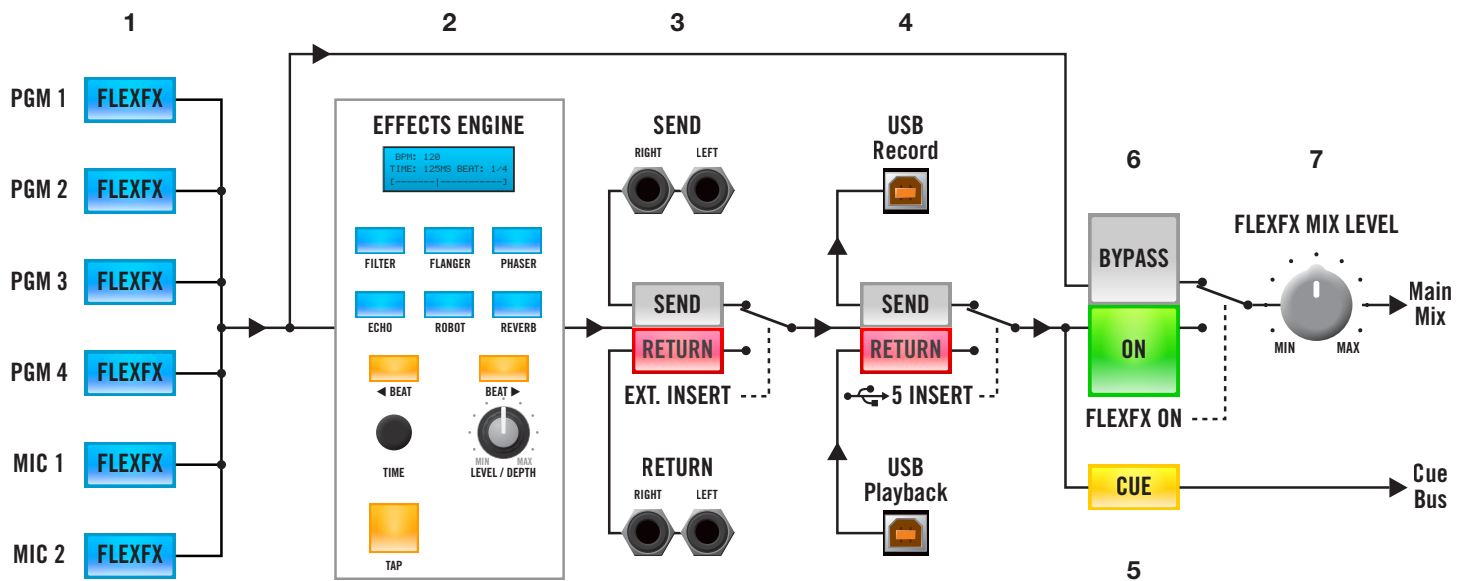

## Internal Audio Effects

The six built-in effects are the Filter, Flanger, Phaser, Hold Echo, Robot, and Reverb. An exciting feature is the Sixty-Eight's ability to synchronize its internal effects to songs tagged with BPM.

## External Audio Effects

Your favorite stereo effects unit, connected to the FlexFX Loop Send and Return, can be inserted independently or in combination with other effects.

## USB Effects

Serato DJ includes FX powered by industry leaders iZotope, enabling you to manipulate your songs and add another dimension to your mix. Additional iZotope FX Expansion packs can be purchased to grow your arsenal of FX. Enable and control the FX in Serato DJ or Scratch Live and apply to the mix by activating the FlexFX Insert.



Rane is pleased to announce that the Sixty-Eight which previously included Serato Scratch Live software is now fully supported by Serato DJ software. DJs currently using Serato Scratch Live with supported Rane hardware have the option to migrate to the new and improved Serato DJ free of charge. If you're familiar with Scratch Live, the transition to Serato DJ is easy and intuitive.

Serato DJ provides support for DVS (digital vinyl system), iZotope FX, Sync,

Slip Mode, more Cue points, jump-to-loop, an improved 24-slot sampler and takes advantage of the high performance, ultra-low latency Rane ASIO and Core Audio drivers. Both programs share compatible song libraries, the same general workflow and deck layout.

Serato's famous Virtual Decks give you all the key track information. Easy to read BPM, time remaining/elapsed, track progress, pitch information and cue point indication are all clearly displayed.

Full color waveforms visually represent the audio frequencies. Red represents bass, green is mid-frequency and blue

represents high treble sounds. The track Overview shows you playhead location and what's coming up.

Library management of your audio and video files is a breeze. Organize your music, build crates, view previous sets and add album art. Serato DJ can also load your iTunes library. Prepare audio files for playback with auto-gain and BPM calculation.

Use keywords, genre, BPM or other rules to create Smart Crates that automatically update. Choose from multiple horizontal or vertical display modes to suit your performance style.

# Sixty-Eight Specifications

Analog Inputs	4 Stereo unbalanced RCA jacks
.....Phono, Line or S/PDIF input	Rear panel switches for each input
.....Phono Response	RIAA $\pm 1$ dB, Gain: 35 dB at 1 kHz
.....Max Phono Input	115 mV
.....Max Line Input	4 Vrms
S/PDIF Inputs	16-bit or 24-bit PCM only
.....SRC Output	Always 24-bit
.....Input Sample Rate	16 kHz to 144 kHz
.....SRC Output Sample Rate	Always 48 kHz
ADCs	24-bit, 48 kHz; Dynamic range 101 dB A-weighted
DACs	24-bit, 48 kHz; Dynamic range 107 dB A-weighted
Digital Signal Processing	48 kHz, 32-bit floating point
USB Audio	Six Stereo Record, Five Stereo Playback
.....	48 kHz, 32-bit floating point
FlexFX Return	Stereo unbalanced 1/4" TS (tip-sleeve) phone jack
FlexFX Send	Stereo unbalanced 1/4" TS phone jack
Mic Inputs	Balanced 1/4" TRS & XLR combination jack
.....Tone Controls	2-band, High and Low
.....Mic 1	+48V Phantom Power on/off switch
.....Mic 2	Mic/Line-level switch
Line Outputs: Frequency Response	20 Hz to 20 kHz $\pm 0.25$ dB, Line in to Line out
.....THD+N	<0.01% re 0 dBFS, 20 to 20 kHz, 20 kHz BW
.....Unbalanced jacks (RCA & FlexFX)	Maximum 4 Vrms
.....Balanced jacks (Main & Booth)	Maximum 8 Vrms
Universal Power Supply	100 to 240 VAC, 50 Hz to 60 Hz, 15 W max
USB Power	Mixer is self-powered
Unit: Conformity	CE, FCC, cULus
.....Size	14.3" H x 12" W x 4" D (36.4 cm x 30.5 cm x 10.2 cm)
.....Weight	11.3 lb (5.2 kg)
Shipping Size	7.75" H x 15" W x 19.25" D (19.7 cm x 38.1 cm x 49 cm)
.....Weight	16 lb (7.26 kg)
Refer to the Appendix in the Sixty-Eight Manual for chassis and ear dimensions.	
All specifications are typical unless otherwise stated.	

## Core Audio & ASIO Drivers

These included drivers allow the Sixty-Eight to act as a 10-in 12-out USB external sound card for use with multiple third-party software clients supporting Core Audio (Mac) or ASIO (Windows). The Sixty-Eight controls are MIDI-mappable with supporting software.

## Computer Requirements

Before purchasing a Mac or PC, please check [serato.com](http://serato.com) for best results with the latest version of Serato DJ.

## Serato Control

Mix files from your computer hard drive using Serato Control Vinyl, Serato Control CD or approved USB Controllers. The Serato Control Vinyl and Control CDs each contain the Serato NoiseMap™ Control Tone, a unique control signal which allows Serato DJ or Scratch Live to track the motion of the record, simulating the same movement with digital audio.

## Included in the Box

- Sixty-Eight Mixer
- 2 USB cables
- Printed color manuals
- 4 Control Vinyl Records
- 4 Control CDs
- Serato DJ software install disc
- IEC C5 line cord.



## [serato.com](http://serato.com)

Features are being added and improved, and the latest version of Serato DJ or Scratch Live is a free download. The Forum at [serato.com](http://serato.com) is the best place for technical support and performance tips from thousands of other DJs.

## [whitelabel.net](http://whitelabel.net)

The Serato Whitelabel Delivery Network is a unique system that allows record labels to digitally deliver promotional releases directly to Serato DJs. To download Whitelabel audio files and sign up for updates on the latest promotional releases, visit [whitelabel.net](http://whitelabel.net).

## [dj.rane.com](http://dj.rane.com)

Visit the Rane DJ website for the most up-to-date information on all Rane hardware, manuals, accessories, support, community, newsletter and blog.

© 2014 Rane Corporation. Accelerated-Slope, FlexFX and Active Crossfader are trademarks of Rane Corporation. All rights reserved. Windows XP, Vista, and 7 are either a registered trademark or a trademark of Microsoft Corporation in the United States and/or other countries. Apple, Mac, Macintosh and iTunes are trademarks of Apple Computer, Inc., registered in the US and/or other countries. Serato DJ and Scratch Live are trademarks of Serato. Lexan is a registered trademark of General Electric. iZotope is a trademark of iZotope, Inc. in the United States and other countries.

1-2014