

# RS 10

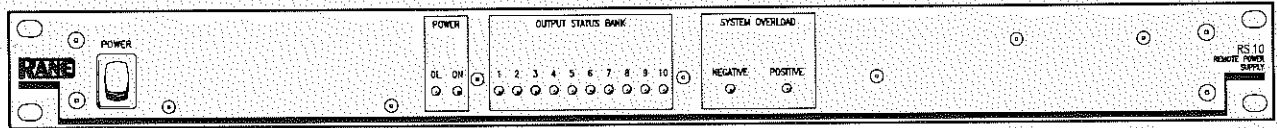

## OPERATING AND SERVICE MANUAL

**RANE**  
CORPORATION

## CONTENTS

I. WARRANTY INFORMATION .....	2
II. FRONT PANEL DESCRIPTION .....	3
III. REAR PANEL DESCRIPTION .....	3
IV. FUNCTIONAL DESCRIPTION.....	4
V. SYSTEM CONNECTION .....	5
VI. OPERATING INSTRUCTIONS.....	6
VII. SPECIFICATIONS .....	7
VIII. SERVICE DIAGRAMS .....	8

## I. WARRANTY EXPLANATION - PLEASE READ CAREFULLY

Rane offers a limited warranty, described in full on the Limited Warranty card included in the packing materials, which covers both parts and labor necessary to repair any defects in the manufacturing of you Rane product.

The warranty period is two (2) years, starting from either (i) the date of retail purchase, as noted on either the sales slip from an authorized Rane dealer or on the warranty registration card sent in to the factory or, (ii) in the event no proof of purchase date is available, from the date of manufacture, which is coded on the rear of the chassis.

If you send in the registration card according to the instructions on the card, or retain your sales slip as proof of purchase, you will receive a full two (2) year warranty period from the date of purchase, regardless of the date of manufacture. If you do not send in the registration card ("I forgot."), or you do not have a sales slip from an authorized Rane dealer ("My dog ate it."), the warranty period will only extend two (2) years from the date of manufacture.

All registered warranties are tracked by serial number, not by owner. Once your Rane product is registered, it will be covered the full two years, regardless of any change in ownership.

Should you encounter any problems with your Rane product, be sure to contact either your local Rane dealer or the Rane factory before taking it anywhere for repairs. We will help you to identify and locate any specific malfunctions, possibly avoid needless shipment, or instruct you as to the speediest method for authorized repair.

If you must send your Rane product to the factory or a warranty station for repair, BE SURE TO INCLUDE THE FOLLOWING INFORMATION:

1. YOUR COMPLETE NAME AND RETURN SHIPPING ADDRESS (P.O. box numbers are NOT acceptable)
2. THE SERIAL NUMBER OF THE RANE PRODUCT IN FOR REPAIR
3. A COMPLETE DESCRIPTION OF ANY AND ALL PROBLEMS YOU ARE EXPERIENCING WITH THE PRODUCT.

**Never ship the unit in any shipping carton other than the original or a replacement supplied by Rane.** Ship only by a reputable carrier. Be sure to insure the package for the full replacement value. Rane cannot be held responsible for any damage incurred during shipping.

### NOTICE REGARDING DAMAGES

THE RANE LIMITED WARRANTY COVERS ONLY THE COSTS IN LABOR AND MATERIALS TO REPAIR DEFECTS IN MATERIAL OR WORKMANSHIP OR, AT RANE'S OPTION, TO REPLACE DEFECTIVE PRODUCTS. CONSEQUENTIAL AND INCIDENTAL DAMAGES SUCH AS ECONOMIC LOSS OR INJURY TO PERSON OR PROPERTY, WHATEVER THE CAUSE, ARE EXCLUDED FROM COVERAGE. PLEASE REFER TO THE LIMITED WARRANTY CARD FOR A FULL DESCRIPTION OF THE LIMITS ON THE COVERAGE OF THE LIMITED WARRANTY.

If you need further assistance concerning the repair, installation or operation of your Rane product, please feel free to contact Rane galactic headquarters at:

Rane Corporation  
10802 47th Avenue West  
Everett, WA 98204-3400  
Phone: (206) 355-6000  
FAX: (206) 347-7757

## II. FRONT PANEL DESCRIPTION

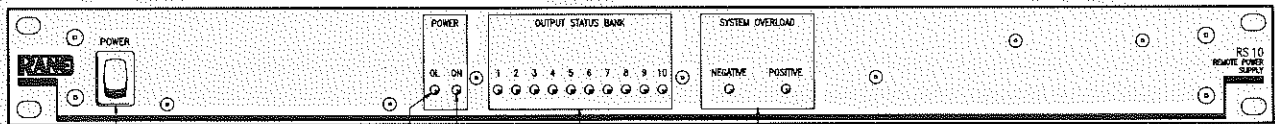

1. **POWER SWITCH:** Pressing the upper portion of this switch will cause power to flow to the internal workings of the RS 10 and eliminate the need for one to worry about the power switches on all other Rane products attached to this one.
2. **MAIN OVERLOAD INDICATOR:** This warning light indicates a thermal overload problem due to improper ventilation. Once triggered, the thermal switch in the AC primary of the power transformer automatically resets after the RS 10 has cooled to normal operating temperatures. Allow 10 to 15 minutes for reset to occur. Improving airflow around the RS 10 should prevent further nuisance tripping. If not, please consult the factory.
3. **POWER ON INDICATOR:** The illumination of this LED signals that the operator has understood the concept conveyed in item 1 above.
4. **OUTPUT STATUS INDICATORS:** These green LEDs illuminate any time the regulated positive and negative 24 volts DC is present at the respective outputs on the rear of the unit.
5. **SYSTEM OVERLOAD INDICATORS:** These red LEDs will illuminate when the total load current of all ten (or fewer) outputs of the RS 10 exceeds either 1 amp on the positive supply or one amp on the negative supply. When illuminated, the respective regulator will be in its current limit state and the 24 volt output level will fall. Reducing the load automatically restores the green lights.

## III. REAR PANEL DESCRIPTION

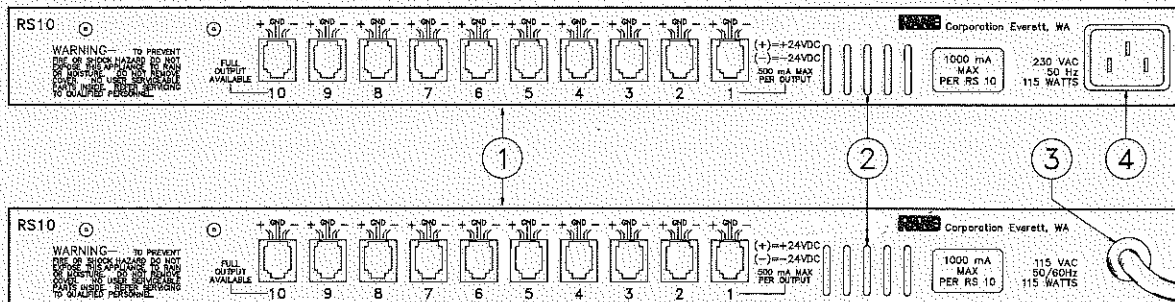

1. **POWER SUPPLY OUTPUTS:** Connect either a 6-pin or a 4-pin modular connector to these outputs to supply power to any piece of Rane equipment equipped with a matching DC input connector. As noted above each receptacle, the two leftmost pins in the connector are +24VDC, the two center pins are 0 volts, or ground, and the two pins on the right supply the -24VDC output. Outputs 1 through 9 are individually limited to a maximum current flow of 500 milliamps each. Output 10 is not restricted in the same manner and can supply the full 1 amp per leg available from the RS 10's regulators.
2. **COOLING VENTS:** Although it may be unusual for a manufacturer to point out such innocuous scenery, we do so in this case to let you know that covering these stylishly radiused openings is a no-no.
3. **AC LINE CORD:** This feature is only available on the domestic USA and selected export versions. If your unit does not come with this feature, you will have to move to get it.
4. **MAINS POWER CORD CONNECTOR:** This IEC connector is provided only on the export 220VAC model, to facilitate the application of any CEE-22 style cord in each country to which the RS 10 is intended for ultimate sale. (Note: the cord is supplied by each foreign distributor; it is not included with the RS 10.)



## IV. FUNCTIONAL DESCRIPTION

The internal workings of the RS 10 are quite simple. Only a cursory understanding of electricity is required to digest the following.

Referring to the block diagram:

Power supplied from the AC mains is converted from the input level (120VAC or 240VAC) to a lower voltage suitable for application to the positive and negative regulators, and then rectified (converted from AC to DC). This rectification is performed by a circuit we call a bridge rectifier. A bridge rectifier, as applied in the manner found in the RS 10, provides full wave (fewer bumps in its outputs) positive and negative DC voltages to the respective regulators.

The regulators to which the outputs are attached are quite substantial. This is because the RS 10 is required to produce a total of 48 volts (24+24) at all times, at a current of one ampere. This is equal to an output power of 48 watts! As anyone in the audio business knows, a 48 watt power amplifier will get warm. There is nothing different about the RS 10, save that it is not as pleasing to listen to. (Exception: fans of Heavy metal).

The regulators used are monolithic (a big integrated circuit instead of a bunch of fussy little parts), a design which greatly improves performance. When all of the critical elements of a regulator circuit are on the same piece of silicon, all will operate at the same temperature as the power controlling transistors, thereby improving the thermal tracking of the device. If a well regulated 24 volts turns your head, you've come to the right place.

Once regulation has occurred, the 24 volt supplies are routed through individual current limiters to each of the first nine output jacks. The current limiters used are known as "posistors", that is, they have a positive increase in resistance when their temperature begins to rise. They are carefully selected so they will not increase in temperature (and therefore resistance) until a current exceeding 500 milliamps flows through them. Once the specified current is exceeded, the devices quickly rise to several thousands of ohms thereby impeding the further application of excess current. Automatic reset occurs upon reduction of output current demand.

Output 10 is not treated to the above procedure. It is current limited only by the regulators (+ and - one ampere). This has been done to allow this output only to supply high current in the event the unit to be powered requires this level of supply.

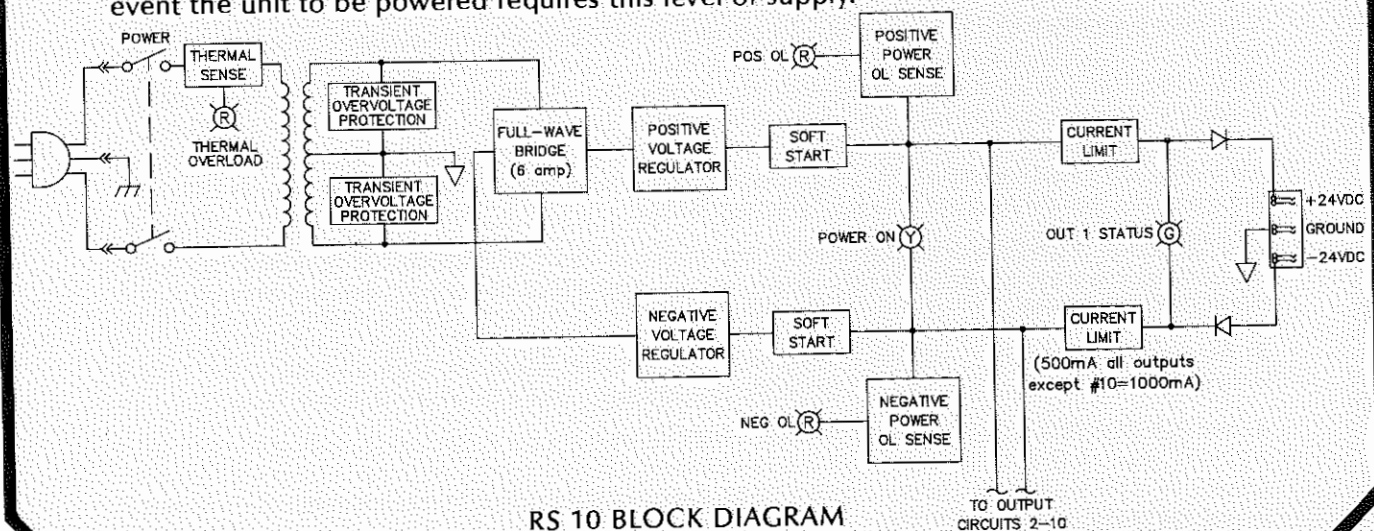

## V. SYSTEM CONNECTION

Optimum performance of the RS 10 requires careful location, mounting, ventilation and wiring.

### LOCATION

Just like a power amplifier, the RS 10 should be located as far from the powered units as practical. The further away, the lower the induced hum components. **Maintain at least one rack space clearance and preferably three for completely hum-free operation.**

### MOUNTING

Make sure the RS 10 chassis is securely grounded to the rack rails, and the rack itself is earth-grounded. Equally important is the necessity to **positively ground each powered unit.** Once the AC line cords are disconnected, the units powered by the remote supply lose their chassis ground connection. All shielding afforded by their steel chassis is lost and must be restored through proper rack-rail grounding.

### VENTILATION

Proper ventilation cannot be over-emphasized when installing the RS 10. Airflow must not be restricted along the right side, rear, or top of the unit. You don't have to get paranoid, just use common sense and don't block the air vents. For example, normal rack mounting with one open space above the RS 10 and unrestricted vertical airflow behind is adequate.

### WIRING

Connect the supplied cables, one at a time, to the output(s) of the RS 10 and to the equivalent connector on the rear of the unit(s) to be powered. If you require more cables than those supplied with the unit, additional packages of 3 each are available from your Rane dealer for a moderate charge. If this is not convenient, you may obtain similar cables from any supplier of telephone paraphernalia. We have used six-pin connectors on both the RS 10 and all Rane products designed to be powered from this unit. Four-pin cables are the most common for domestic telephone equipment and they will work with the RS 10. The only difference between the six-pin variety and the four-pin is that with six there are two conductors per polarity rather than just one in the four wire version. In both cases, there will be two ground conductors. At the current levels encountered in all RS 10 applications, one conductor per leg is sufficient.

Once the outputs of the RS 10 are connected to all of the individual component inputs, ensure that the power switch on the front panel of the RS 10 is in the off (down) position and connect the AC cord to an appropriate AC receptacle. Having done all of this you are ready to turn the page.

## VI. OPERATING INSTRUCTIONS

### INITIAL POWER-UP

When the directions in the preceding section have been faithfully accomplished, you will be ready to turn on the RS 10 for the first time and experience the light show presented on the front panel.

The appropriate sequence for the LEDs follows:

1. The two red System Overload LEDs illuminate.
2. The yellow Power On LED slowly begins to glow.
3. As the two red System Overload LEDs begin to dim the ten green Output Status LEDs slowly turn on.

When the ten green LEDs are fully on and the two red System Overload LEDs are completely off, everything will be ready to go.

If, for some reason, the current demand of the total of all of the outputs exceeds one amp on either the positive or negative leg of the power supply, either or both of the red System Overload LEDs will not extinguish, depending on the nature of the current flow. Some units, especially those with either a lot of LEDs or some digital processing going on inside may exhibit asymmetrical current requirements and thus cause an overload on only one polarity of the power supply. In a case such as this, one System Overload indicator may stay red and the other will extinguish. In any event, disconnecting the outputs one by one should be an acceptable means of locating the overload. The following table provides a guide to the current requirements of Rane products:

MODEL	CURRENT	MODEL	CURRENT
AC 22.....	100mA	MP 24 .....	400mA
AC 23.....	100mA	PE 15 .....	100mA
GE 14.....	200mA	RA 27 .....	300mA
GE 27.....	150mA	RE 14 .....	350mA
GE 30.....	200mA	RE 27 .....	400mA
ME 15.....	100mA	SM 26.....	100mA
ME 30.....	100mA	SP 15 .....	100mA

### TROUBLESHOOTING TIPS

Should there be an instance where all of the lights indicate normal performance for a period of time (minutes to eons), and suddenly one of the green lights goes out or one of the red lights comes on, troubleshooting is relatively simple. If a green light goes out, chances are removing the associated connector from the rear of the RS 10 will make the LED come on again. (This will take a few seconds while the posistor protecting the output cools off.) If the green light comes back on, disconnect the other end of the cable from the unit being powered by this output and plug the other end back into the RS 10. If the green light goes back out, the cable is bad (shorted). If the green light stays lit, reconnect the cable to the back of the unit under power. If the green light still stays on, see your doctor. If the light goes away, send the unit under power to its doctor.

If one (or both) of the system overload lights come on after the RS 10 has had a history of successful operation, follow the preceding procedure. This should isolate the cause to cable, slave unit or RS 10.

## VII. SPECIFICATIONS

Output Voltage:  $\pm 24\text{VDC}$ ,  $\pm 4\%$

Output Current: 1000mA guaranteed (total of all outputs)  
500mA: Outputs 1-9  
1000mA: Output 10

Output Connectors: (10) RJ-12 (6-pin) modular connector jacks  
(2) parallel pins used for each voltage and ground for maximum reliability

Line Regulation: 0.5%

Load Regulation: 0.5%

Transient Overload Protection: (2) Varistors

Output Protection: Positive Temperature Coefficient Resistors (PTC)  
Self-resetting

Primary Overload Protection: Self-resetting thermal switch ( $100^{\circ}\text{C}$ )

AC Line Connection:

115VAC Domestic & Selected Export Models: 3-wire, 3-prong line cord  
220VAC Export Models: IEC connector for CEE-22 power cords  
(Note: correct power cords supplied by each foreign distributor)

Maximum Power Consumption: 115 Watts

Line Voltage: Domestic & Selected Export Models: 95-130VAC, 50/60Hz  
Export Model: 190-250VAC, 50Hz

Size: 1.75"H x 19"W x 5.25" rack depth

Weight: 6 lbs. net

All specifications subject to change without notice, hopefully for the better.



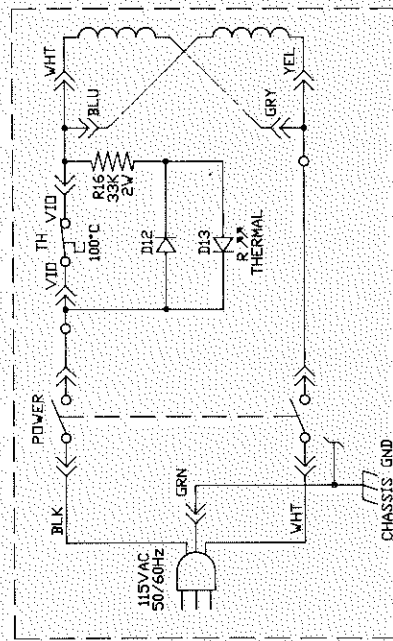
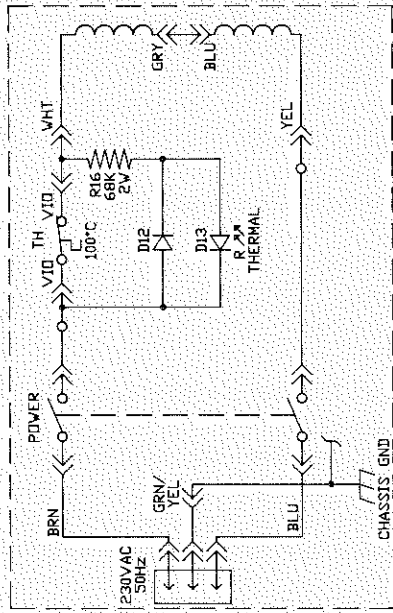
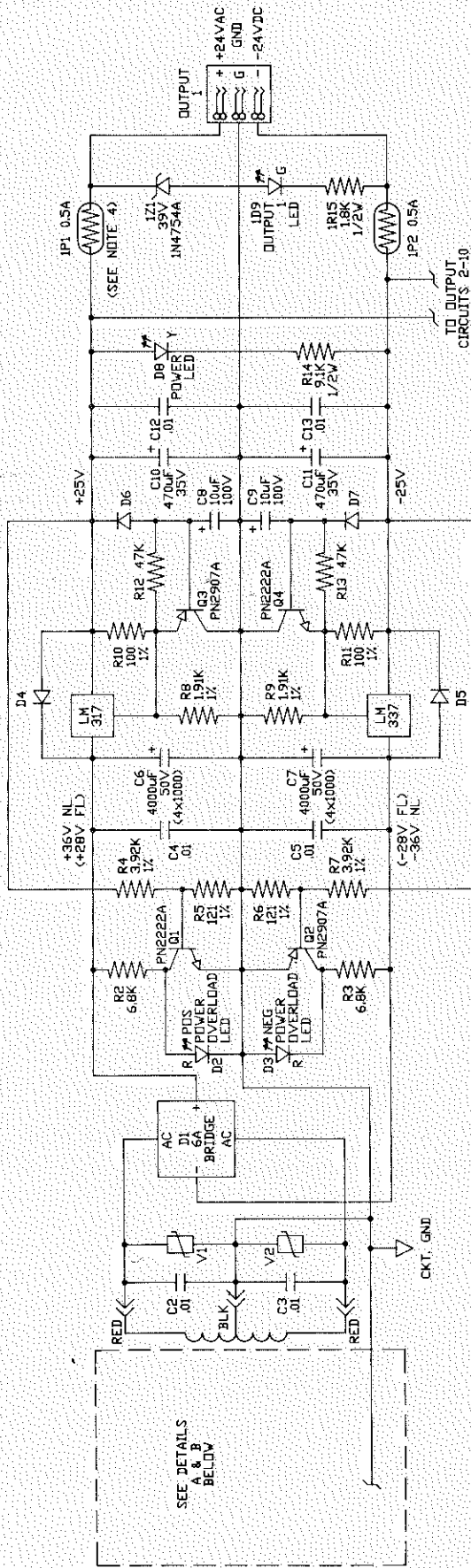

- NOTES (UNLESS OTHERWISE NOTED):
1. ALL RES 1/4W 5% CARBON FILM
  2. ALL 1/2 RES METAL FILM
  3. ALL CAPS 50V CERAMIC DISC.
  4. ALL DIODES 1N4004.
  5. POSISTORS OMITTED ON OUTPUT 10.





CORP. 6510 216TH S.W. MOUNT LAKE TERRACE,  
VA 98043 (206) 774-7309

TITLE RS10 SCHEMATIC  
DRW. NO. 521-032  
REV. B

REV. B	ACTION	DATE 12FEB87	CHECKED DB	DATE 28FEB87	SHEET 1 OF 1	DATE 12EC87	APPROVED
DRAWN	STB	DATE 12FEB87	CHECKED DB	DATE 28FEB87	SHEET 1 OF 1	DATE 12EC87	APPROVED

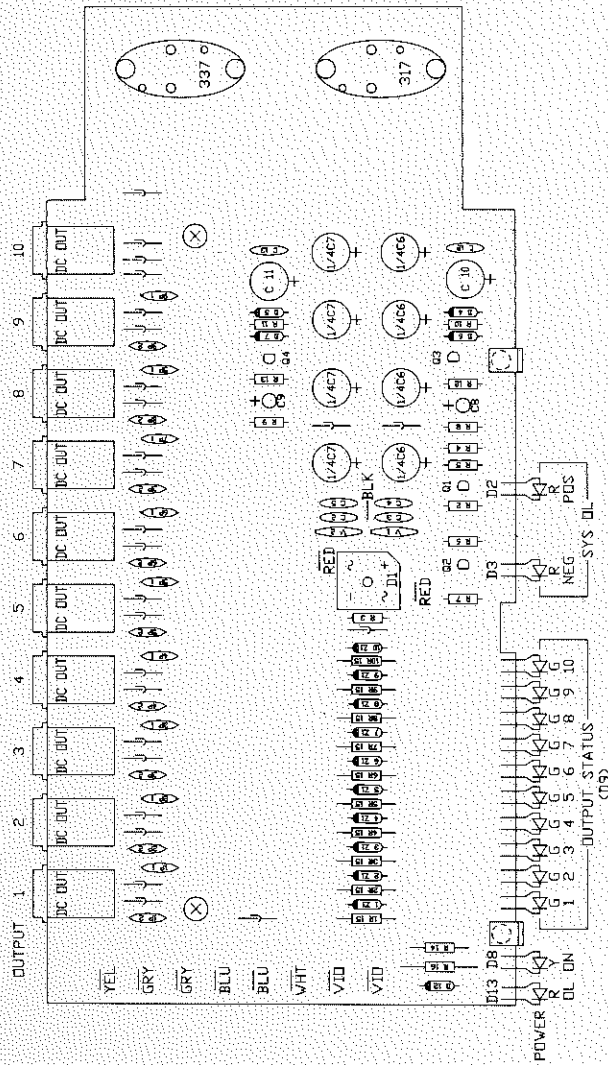
DO NOT SCALE DRAWING.



		TITLE RS 10 ASSY	REV A
CORP. 6310 216th S.W. MOUNTLAKE TERRACE VA 98043 (206) 774-7209		DRW. NO. 522-030	

REVISIONS REV. A DRAWN S. TURKIDGE	ACTION DATE 22OCT87	DATE 11DEC87 APPROVED	SHEET 1 OF 1 DO NOT SCALE DRAWING
--	------------------------	--------------------------	--------------------------------------