

RPS 4 Remote Program Selector

General Description

The Rane RPS 4 Remote Program Selector converts switch closures to MIDI program changes. The RPS 4 allows remote control of any MIDI programmable device in your system. Select up to four preset programs by simply pressing a button, throwing a switch, or turning a knob. (The RPS 4 can recall up to (16) programs. Please consult the MPE Users Guide for binary switch instructions.) For example, using the RPS 4 with Rane's innovative MPE series of programmable equalizers allows you to change EQ with the touch of a switch. Adding MIDI programmable time delay and reverb units lets you recall different time delay settings, or change reverb parameters; or change EQ, time delay and reverb all together.

The RPS 4 works with any MIDI unit, on any of the 16 possible MIDI channels, and solves the problem of allowing simple recall of program changes, while restricting access to the programmable devices. All you do is program them, add an RPS 4, and lock them up. The user now selects different programs for different times of the day, different days of the week, different occupancy rate, different speaker use or coverage, etc.

This unit interfaces with any type of switch: rotary, toggle, or momentary pushbutton. One innovative feature of the RPS 4 allows wiring a 4-position selector switch using only standard 2-conductor shielded cable. Another, lets you use 4 pushbuttons—each with an LED indicator—and the wiring consists of only a 4-conductor shielded cable (or a 5-conductor unshielded cable if you prefer). If only two program changes are needed then life just gets simpler: a 2-position selector switch requires only a single conductor shielded cable, or 2 momentary pushbuttons use normal 2-conductor shielded cable. See application section on rear for details.

Power for the RPS 4 comes from the included RS 1 Remote Power Supply. To use one less power supply with an MPE unit, the POWER OUT jack on the RPS 4 allows daisy chaining of power between it and the MPE.

Application Information

Use of the RPS 4 is pretty obvious and shouldn't present any problems. Here is a short check list:

1. Connect a MIDI cable (standard 5-pin DIN) between the MIDI OUT jack on the RPS 4 and the MIDI IN jack on the unit to be controlled. When controlling more than one MIDI unit at a time, connect the RPS 4 MIDI OUT jack to the MIDI IN jack on the first unit, then connect the MIDI THRU jack from the first unit to the MIDI IN jack on the second unit, and so on. (*Do not use the MIDI OUT jacks except on the RPS 4.*)

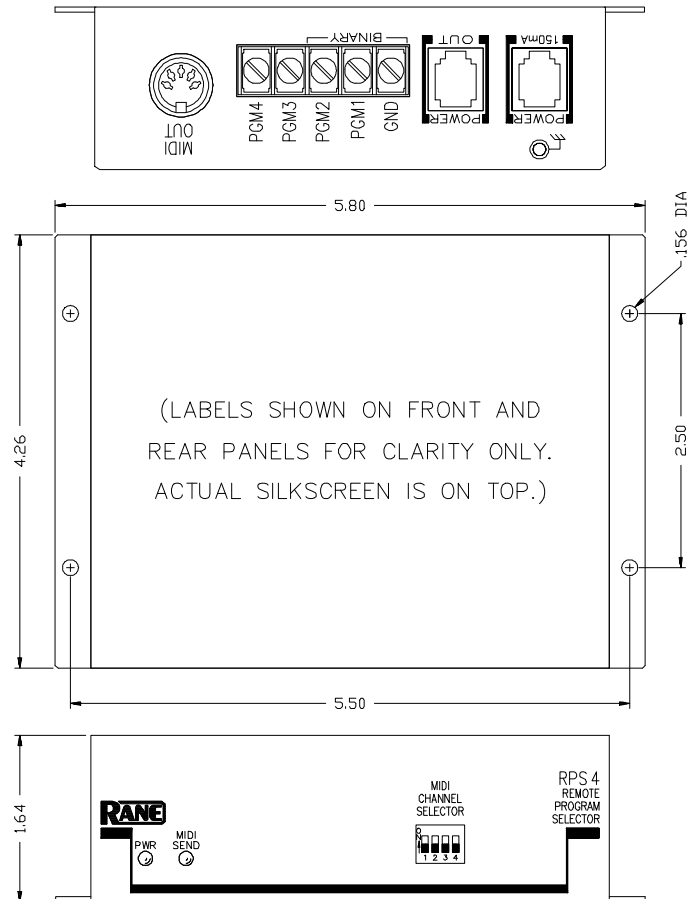

Features

- **AUTOMATICALLY CONVERTS SWITCH CLOSURES TO MIDI PROGRAM CHANGES**
- **ACCEPTS ONE TO FOUR SWITCHES***
- **ROTARY OR PUSHBUTTON SWITCHES***
- **OPTIONAL PUSHBUTTON LEDs**
- **CHOICE OF 16 MIDI CHANNELS**
- **CERTIFIED CLASS B DIGITAL DEVICE PER FCC RULES & VDE 0871**
- **UL LISTED REMOTE POWER SUPPLY (SOLD SEPARATELY)**

2. If controlling a Rane MPE equalizer, and one less RS 1 power supply is desired, one RS 1 can power both units. A mod jumper cable can be assembled or purchased from Rane (see reverse). Disconnect the power supply cable from the red POWER jack on the MIDI unit and reconnect it to the POWER jack on the RPS 4. Next, using the jumper cable, connect the POWER OUT jack on the RPS 4 to the MIDI unit's red POWER jack. All other applications require using the Rane RS 1 remote power supply, connected to either red POWER jack. *... continued*

Wiring Diagrams: 2-Program Changes

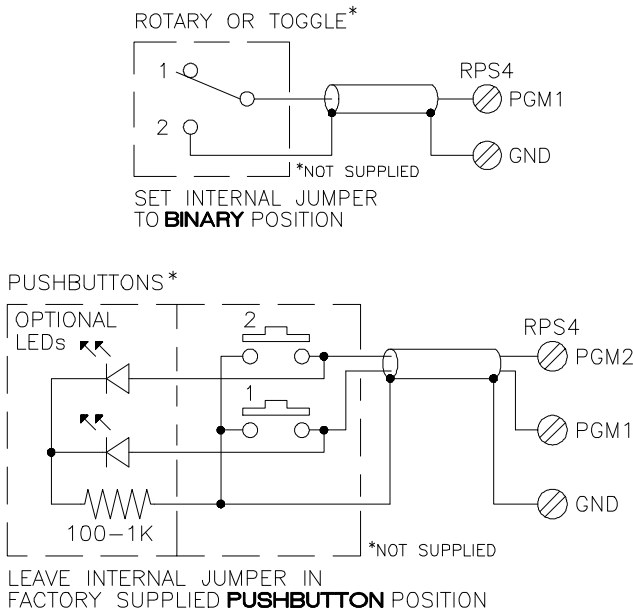

Wiring Diagrams: 4-Program Changes

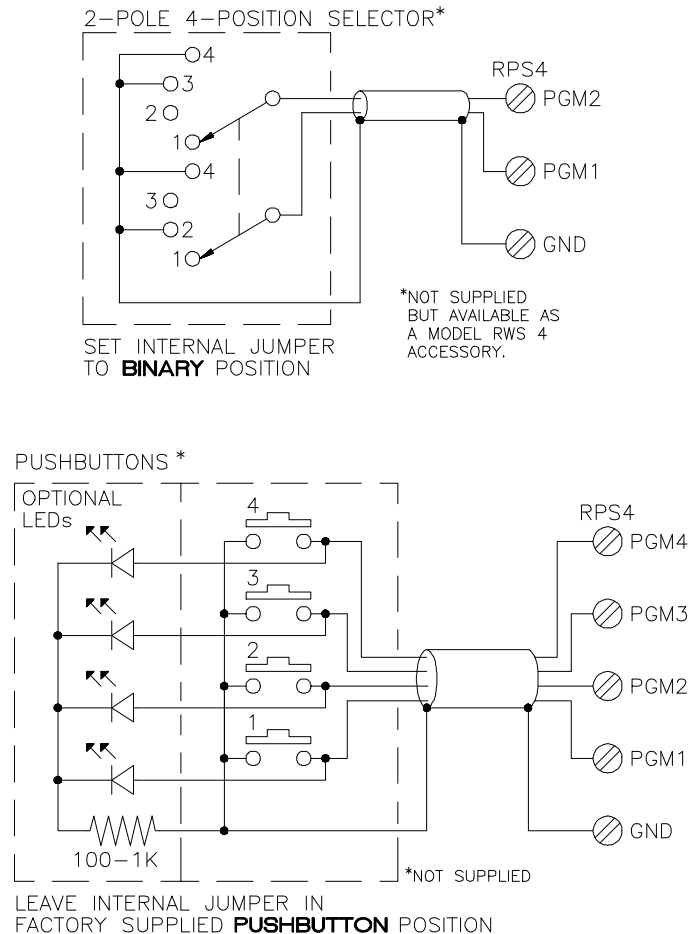

Application Information *continued...*

- Use the MIDI CHANNEL SELECTOR to set the desired channel. All units being controlled must use the same MIDI channel. Refer to the diagrams on the top of the RPS 4 for the correct switch settings.
- The final step is wiring up the switches. Refer to the diagrams above for several choices. The RPS 4 works with all types of switches. Select from those shown and proceed accordingly.

Note there is an internal jumper option labelled BINARY or PUSHBUTTON. All RPS 4s are shipped with this jumper installed in the PUSHBUTTON mode. As the name implies, this is the correct position when using momentary pushbuttons to change programs. If desired, you may add LED indicators to the pushbuttons, without increasing the number of wires being used. Just follow the diagrams shown.

Changing the jumper to the BINARY position allows using the minimum number of interconnecting wires. Sometimes this represents a significant cost savings and convenience. For example, 2-program changes need only a single-conductor shielded cable, while 4-program changes use standard 2-conductor shielded cable.

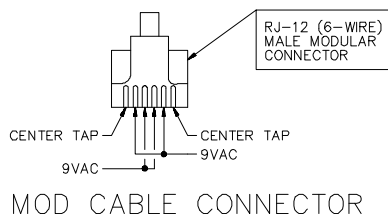

Maximum Recommended Wire Lengths

Wire Gauge	Assumed Ohms Resistance per 1000 feet	Max Distance to Switch Box
24	26	575ft (175m)
22	16	900ft (274m)
20	10	1500ft (457m)
18	6	2500ft (762m)
16	4	3750ft (1143m)

Grounding Note: The RPS 4 inputs are protected internally against static damage. For improved protection of connecting equipment against large static voltages (i.e. shuffling on the carpet and hitting a remote switch) the chassis should be connected to a good earth ground.