



General Description

The RPM 2 is a *100% drag and drop configurable* DSP-based device, set up and controlled using Rane's Drag Net™ software. Industry standard 10Base-T Ethernet is used to communicate between Drag Net devices and any Ethernet-equipped PC running Microsoft Windows®. See the Drag Net data sheet for the current software features and specifications.

Drag Net offers the ultimate in signal processing flexibility, allowing you to draw the system you need without signal flow restrictions. Familiar Windows file management tools and Shortcuts are incorporated into Drag Net, allowing complete project management within a single interface.

The RPM 2 provides two balanced, line-level analog inputs and two balanced analog outputs, each I/O having its own 100% user-defined signal processing path.

Cost-effective end user control is possible using optional Rane accessories in conjunction with the Versatile Input Port. Whether your application requires contact closure Preset recall or remote level control using a potentiometer on a wall, the RPM 2 keeps the user interface easy *and* inexpensive.

Euroblock connectors are provided for audio and logic I/O. On the rear panel is an RJ-45 Ethernet connector for computer control, and an IEC AC power input.

All DSP algorithms are not created equally and textbook DSP algorithms miss the mark where the rubber meets the road. Rane's team of audio-savvy DSP mathematicians — a rare breed itself — in conjunction with our industry-leading analog signal processing gurus have combined forces to offer superlative digital *and* analog audio performance. With 24-bit converters, greater than 105 dB throughput dynamic range and double-precision 48-bit internal DSP “math,” the RPM 2 offers the best DSP algorithms and audio performance available.

This ain't no Internet appliance! For example, the RPM's 215 MIPs translate into 150 fully parametric EQ filters, should you need multiple channels of 15 band parametrics and nothing else.

Multiple units are controlled from a single computer using low-cost Ethernet switches. The recessed Default button on the rear panel recalls Preset 1 in case of communications failure. The front panel has three-color LED meters for each input and output, allowing fast and intuitive signal flow verification without a computer. Current Preset, Control Port, Power, Ethernet and Status indicators are also on the front panel. Powered from an internal power supply and certified as UL, CSA and CE compliant, the RPM 2 is compatible with any installation mandating agency compliance.

Software Features

- Drag Net™ setup & control software for Windows®
- Signal flow and critical settings in plain view on one screen
- 24 fully programmable processing configurations
- Expandable collection of processing blocks
- Firmware upgrades via Ethernet connection
- Download Drag Net at www.rane.com



Hardware Features

- 2 balanced analog Inputs and Outputs
- Powerful DSP, up to 48-bit precision processing
- 105 dB dynamic range
- Preset recall via contact closures
- Versatile Input Port for remote control via voltage
- 10Base-T Ethernet control
- UL/CSA/CE internal power supply (100-240 VAC)

*Drag Net runs with Windows XP, Vista and 7.
Windows is a registered trademark of Microsoft Corporation
Drag Net is a trademark of Rane Corporation*

Features and Specifications

Parameter	Specification	Limit	Units	Conditions/Comments
Analog I/O	Active Balanced			Euroblock connectors
Input Trim range	+16 to -20 (plus mute)		dB	1 dB steps
Line Gain Setting	0	1	dB	
.....Input Impedance	21.7k	1%	Ω	@ 1 kHz, “+” to “-”
.....THD+N	0.005	typ	%	+4 dBu, 1 kHz, 20 kHz bandwidth
.....Maximum Input	+24	typ	dBu	gain at 0 dB
Output Trim range	+16 to -30 (plus mute & polarity invert)		dB	½ dB steps; gain above unity is digital, attenuation below unity is analog
.....Impedance	100		Ω	Each leg to ground
.....Maximum Level	+23 (+24 unloaded)		dBu	@ 1 kHz, 2 kΩ load
Frequency Response	10 Hz to 20 kHz	+0/-1	dB	
Dynamic Range	105	min	dB	Input Gain at 0 dB, A-weighted
IM Distortion (SMPTE)	<0.01	0.01	%	60 Hz / 7 kHz, 4:1, +4 dBu
Crosstalk	100	typ.	dB	1 kHz bandpass, any channel
Input & Output RFI Filters	Yes			
Audio Converters	24 bit			
Audio Processing	24 bit and higher			48 kHz sample rate
Propagation Delay	1.58	min	ms	Analog I/O, no processing blocks
Internal Memory	Non-volatile			Flash and NOVRAM or FRAM
DSP MIPs	215	2%	MIPs	MIPs = Millions of Instructions Per Second
Communications Interface				
Ethernet	10Base-T			10 mega bit/sec; RJ-45 connector
Max cable length	328 feet / 100 meters			Standard Ethernet CAT 5 cable length limits
VIP (Versatile Input Port)	10-pin Euroblock			8 Inputs, plus REF voltage & ground
Type	8-bit A/D Converter ½ LSB			
Input Range	Vref + 0.3, GND - 0.3 V			
.....Filter	15	5%	Hz	Low-pass 2nd-order Butterworth
.....Passive Pull-up	100k	1%	W	To Vref
Vref	5	4%	VDC	100 mA maximum
Preset recall time	500	typ	ms	Via software or contact closure. The unit recalls quickly, software may take longer.
Meter Range	60		dB	Peak Response
Unit: Power Requirement	100 to 240	±10%	VAC	50/60 Hz, 1.25 to 0.9 Amp
Ambient Temperature	50	max	°C	Minimal external loading
	40	max	°C	Maximum external loading
Agency Listing	Safety			
.....UL	UL6500			File E193164
.....cUL (Canada)	CAN/CSAE60065-00			
.....CE	LVD 73/23/EEC			EN60065
EMI: CE				EMC directive 89/336/EEC
.....FCC	Part 15B			Class B Device
Construction	All Steel			
.....Size	1.75"H x 19"W x 8.25"D		1U	(4.4 cm x 48.3 cm x 20.9 cm)
.....Weight:	5 lb			(2.3 kg)
Shipping: Size	4.5" x 20.3" x 13.75"			(11.5 cm x 52 cm x 35 cm)
.....Weight:	8 lb			(3.6 kg)

Block Diagram

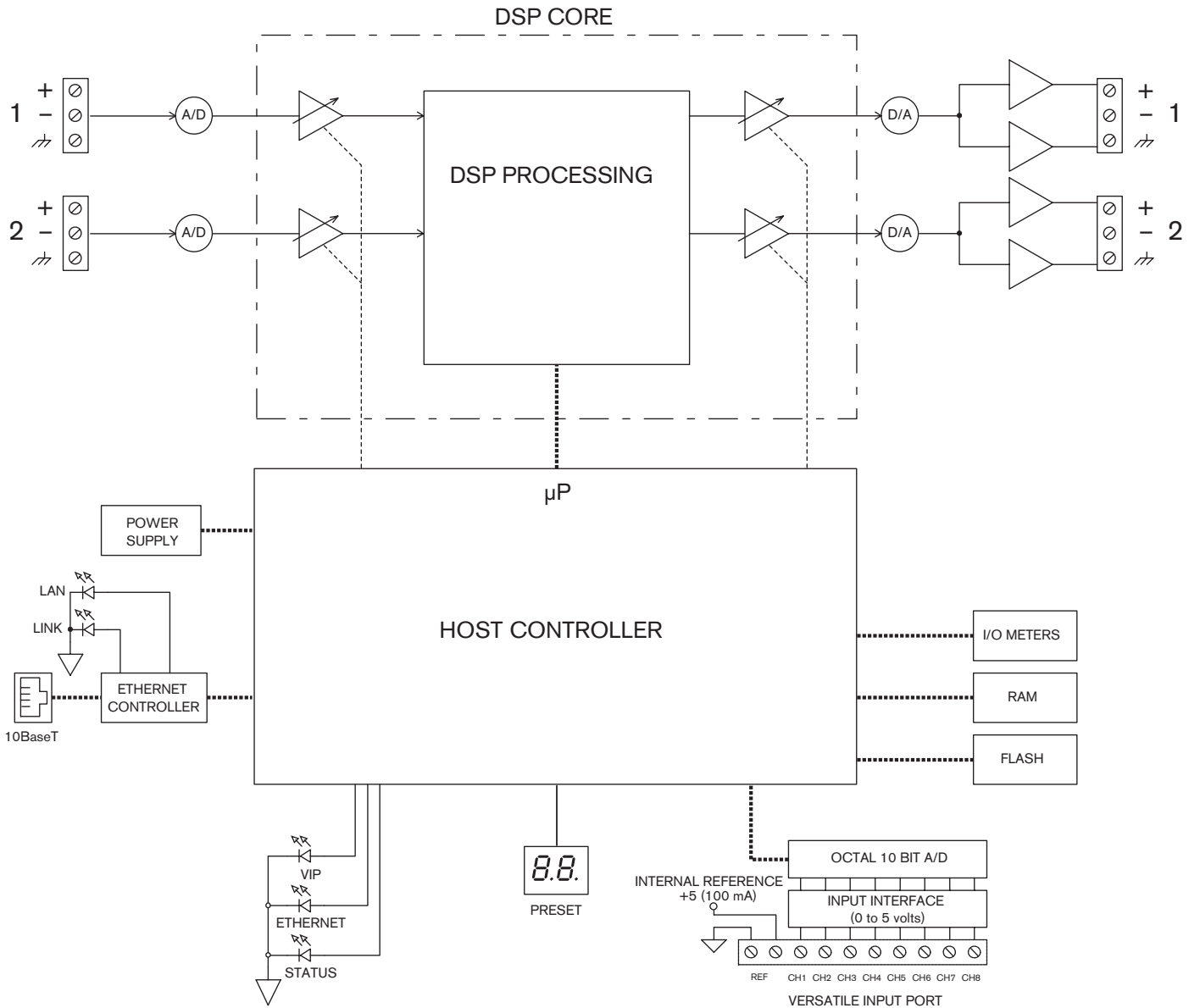

RPM Family Comparison

Model	Analog Inputs	Analog Outputs	AES3 Input	AES3 Output	Total Inputs	Total Outputs
RPM 2	2 line	2	no	no	2	2
RPM 2m	2 mic/line	2	no	yes	2	4
RPM 26z	2 line	6	yes	no	4	6
RPM 22	2 mic/line	2	yes	yes	4	4
RPM 44	4 mic/line	4	yes	yes	6	6
RPM 88	8 mic/line	8	yes	yes	10	10

Rear Panel

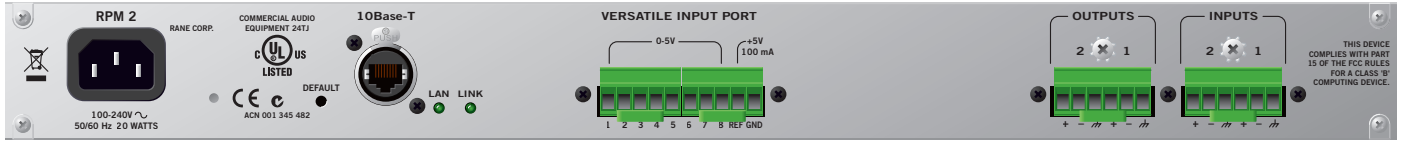

Accessories



MRS 4 Memory Recall Switch



LRS 4 Level Recall Switch



VR 2 Volume Remote

See the Data Sheet of each Remote for details.

Architectural Specifications

The device shall provide two balanced line-level inputs and two balanced line-level outputs. The inputs shall be 100% controllable via software, including gains.

Analog audio inputs and outputs shall be accessible via rear panel Euroblock connectors. A standard, low-cost Ethernet switch shall be used to network and control multiple units via 10Base-T.

The signal processing configuration shall be 100% user programmable under the Windows® XP operating system. The control software shall provide complete display and control, in graphical form, of all signal processing configurations and functions. Downloadable via a rear panel, industry-standard, Ethernet 10Base-T control port, the signal processing configurations shall be 100% drag and drop configurable (not fill in the blanks) utilizing a variety of digital signal processing algorithms, including but not limited to:

- Input & output gains with meters.
- Parametric bandpass, all-pass, high & low shelf & cut filters.
- Feedback elimination.
- Graphic equalization with Perfect-Q™ response.
- Linkwitz-Riley, Butterworth, Bessel crossovers.
- Compression, limiting, Automatic Gain Control (AGC).
- Mix, select, level control, delay.
- Pink noise and sine wave generators.

Control ports shall include 8 logic inputs for contact closure preset recall or potentiometer level control. There shall be 24 internal, non-volatile Presets to store settings for later recall us-

ing a dedicated on-site computer or via external contact closure, making the computer optional once the unit is programmed. Contact closure ports shall be able to be paralleled for recalling the same Preset number across multiple units. A recessed, rear panel default switch shall provide recall of Preset 1 to restore the unit to a known state in the event of communications failure.

All processing settings shall always be stored in nonvolatile memory within the unit, thus allowing for power or computer failure without loss of settings.

Data conversion shall be 24-bit, 48 kHz sampling rate using up to 48-bit internal DSP processing with a minimum 104 dB dynamic range.

The unit shall have no front panel controls, but shall provide 3-color LED meters for each input and output level. There shall be front panel Power, Status, Ethernet, and control logic port communications indicators, and an illuminated display of the currently recalled preset. The rear panel shall provide Ethernet Link and LAN indicators.

The device shall have certified compliance with FCC Part 15J for a Class B computing device and EMC/89/336/EEC (CE certified). The device shall feature a built-in universal voltage power supply capable of operating from 100 to 240 VAC, 50-60 Hz. The unit shall feature an IEC socket line cord. The unit shall meet UL/CSA and CE safety requirements. The unit shall be constructed of cold-rolled steel and mount into a standard 19" 1U EIA rack. The unit shall comply with the AES48 Grounding Standard.

The unit shall be a Rane RPM 2 Programmable Multiprocessor.