

### Intuitive Predefined Configurations

- Dual 2-way or 3-way crossover or up to a mono 6-way crossover with program compression, delay, parametric EQ and limiting
- 1 Input split to two 2-way or 3-way crossovers
- Up to a 1 x 6 digital delay with parametric EQ
- Up to a 2 x 6 matrix signal router with parametric EQ
- 1 x 6 splitter or dual 1 x 3 splitter

### Applications

- Progressively delayed reinforcement or ceiling speakers
- Room combining and distribution
- Critical cluster alignment
- Churches, auditoriums, restaurants, lounges, gymnasiums
- Board rooms, race tracks, court rooms, convention centers

### Features

- New 24-bit data converters @ 50 kHz sample rate
- 24-bit and higher precision processing
- 102 dB dynamic range
- Easy-to-use setup & control software for Windows 95/98®
- Signal flow and critical settings in plain view on one screen
- Detailed device report printouts
- Up to 16 memory contact closure configuration recall
- Setup at the office, optimize at the site
- Optional input isolation transformers (Rane part #00961)
- UL/CSA/CE remote power supply (85-265 VAC)

### General Description

The RPM 26v provides all required signal processing between the mixer and amplifiers. With its insightful, preprogrammed configurations and user-friendly RaneWare® software, the RPM 26v includes a wide variety of intuitive signal processing functions: high & low cut filters, compression, delay, crossover, parametric EQ, splitting, input summing, limiting, trim controls and sine wave or pink noise test tones.

The RPM 26v contains 2 analog inputs, 6 analog outputs and saves several rack spaces with its tamperproof, dead-front, 1U chassis. Configurations and settings are stored in 16 internal, non-volatile memories—which are contact closure accessible from the rear panel Memory Recall Port. This Port can be paralleled with the Ports of other RW 232 products—allowing one hardware switch to select entire system configurations. This makes the RPM 26v ideal for installations requiring preset configurations through simple contact closures. All 16 memories are accessible from RaneWare's Site Control Panel.

The RPM 26v is programmable via its rear panel RW 232 port that interfaces directly to the RS-232 ports found on PC compatible computers. This eliminates the need for a special cable, box or interface card. Up to sixteen RW 232 units at a time can be serially linked to a single computer. Thus a sound system installer can access and program each device on line without having to unplug from the first device and plug into the next. The RW 232 port is also compatible with AMX and Crestron controllers. Once the RPM 26v is programmed, the computer is strictly optional.

The RPM 26v employs 24-bit A/D & D/A converters with 24-bit double-precision internal DSP processing. Euroblock connectors are provided for audio and the Memory Recall Port. The recessed Default button on the rear panel recalls Memory 1 in case of computer failure. The Device Address switch assigns one of 250 possible RW 232 addresses that uniquely identifies each device on the RW 232 bus. The front panel has two-color, signal present and overload indicators for both the Inputs and the Outputs—allowing for fast and intuitive signal flow verification without the need of a computer. Power and COM (communications) indicators are also on the front panel to verify proper AC supply and communication with the computer.

Powered from a UL listed, CSA and CE certified remote power supply, the RPM 26v may be used in any installation mandating agency compliance.

Rane's easy-to-use, Windows-compatible software—called RaneWare (included with the unit and available on our website at <http://www.rane.com>)—allows the RPM 26v (and other RW 232 units) to be controlled in real time. RaneWare also supports saving memories—which include configuration changes—to a file. This allows programming units without being physically connected to them, and allows different configurations to be stored in each Memory. Thus units may be initially programmed at the office, then “tweaked” on site.

The software provides password security, allowing only memory changes, thus disallowing further access. The software also provides metering for Input trims, A/D “number of bits toggling,” and Compressor Gain Reduction meters. “Stereo” Linking of Input Trims, Delays and Output Trims as well as Combining of Compressors and Limiters are also supported. Frequency steps for High and Low Cut filters, Crossover and Parametric EQ are adjustable in 1 Hertz steps. The Crossovers and Extended Parametric EQ (included in some of the preprogrammed configurations) support Linkwitz-Riley, Bessel or Butterworth filters (12, 18 or 24 dB/Octave, where applicable). All Parametric EQs contain ¼ dB boost/cut steps with a +12 / -15 dB range and 80 Q steps between 40 and 0.5 (bandwidths between 0.036 and 2.54 octaves, respectively). Double clicking on the software's Output terminal displays the computed Overall Response curve for the Output(s). This screen allows independent viewing of the frequency response contribution of the Input EQ (High & Low Cut or PEQ Filters), the Crossover (if applicable) and the Output (Parametric) EQ. Ramping can be enabled for smooth transitions between parameter settings, or disabled when not needed (during setup, for example).

RaneWare also prints device reports containing all of the device's parameter settings, along with each Output's Overall Response curve.

When required, optional input isolation transformers (Rane part #00961, two required) are available (see last page of this data sheet).

## 14 Pre-Defined DSP Programs

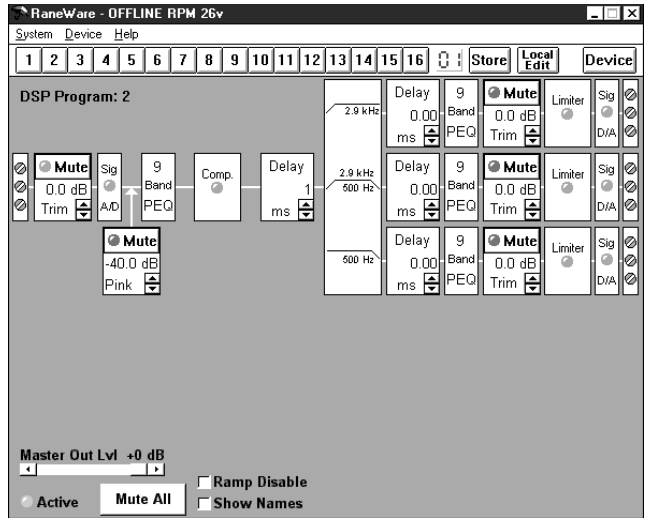

**DSP Program 2 - “Power” 3-way Crossover System**  
1 input, 3 outputs, and 36 bands of PEQ; 9 on each leg. *Extremely cost effective compared to equivalent solutions!*

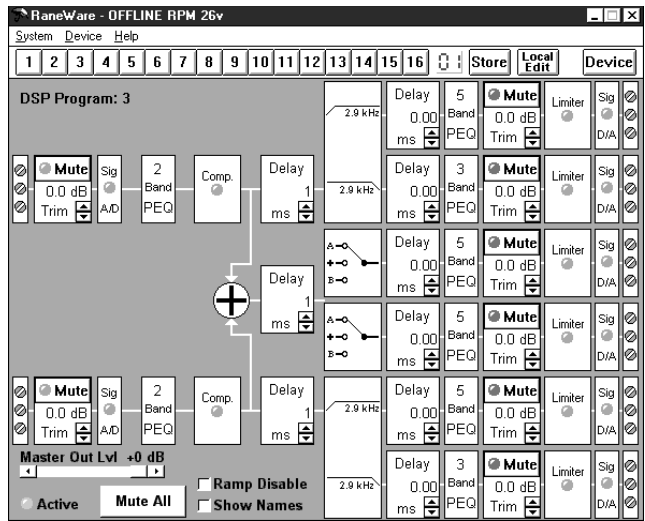

**DSP Program 3 - Dual 2-way Crossover System**  
2 additional “flexible” outputs; 2 inputs, 6 outputs. 30 bands of PEQ; Most PEQ bands on outputs (see Program 9). “Extra” 2 outputs allow mono/stereo subs or 2 full range feeds.

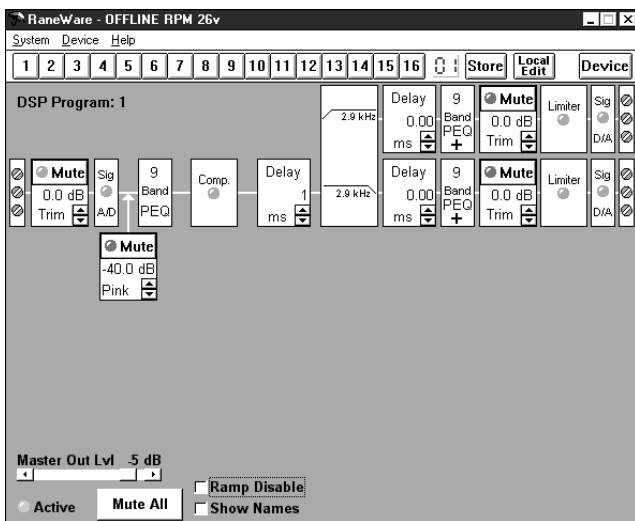

**DSP Program 1 - “Power” 2-way Crossover System**  
1 input, 2 outputs, 27 bands of PEQ; 9 on each leg! Extended PEQ+ allows 8th order, 48 dB/oct Linkwitz-Riley Crossover. Pink noise or sine wave generator.

Data Sheet-2

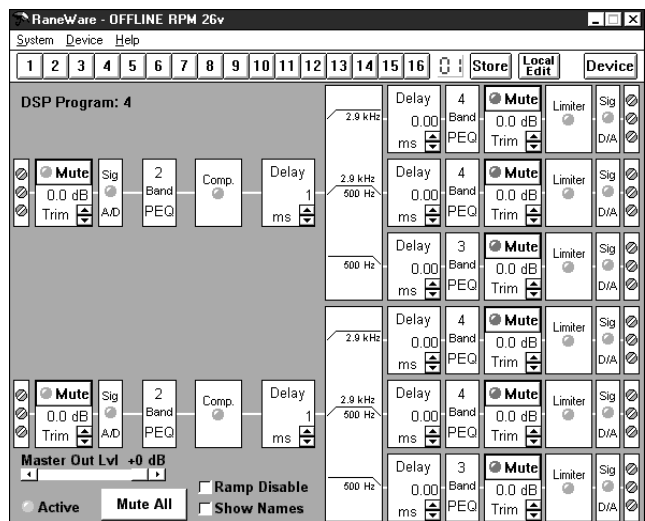

**DSP Program 4 - Dual 3-way Crossover System**  
2 Inputs, 6 Outputs; 26 bands of PEQ; Most PEQ bands on Outputs (see DSP Program 5). *Extremely cost effective compared to equivalent solutions!*

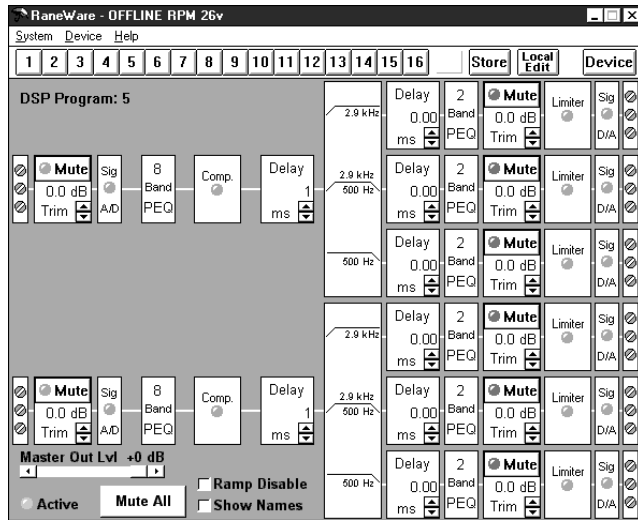

**DSP Program 5 - Dual 3-way Crossover System**  
 2 inputs, 6 outputs; 28 bands of PEQ; Most PEQ bands on *Inputs* (see DSP Program 4).  
*Extremely cost effective compared to equivalent solutions!*

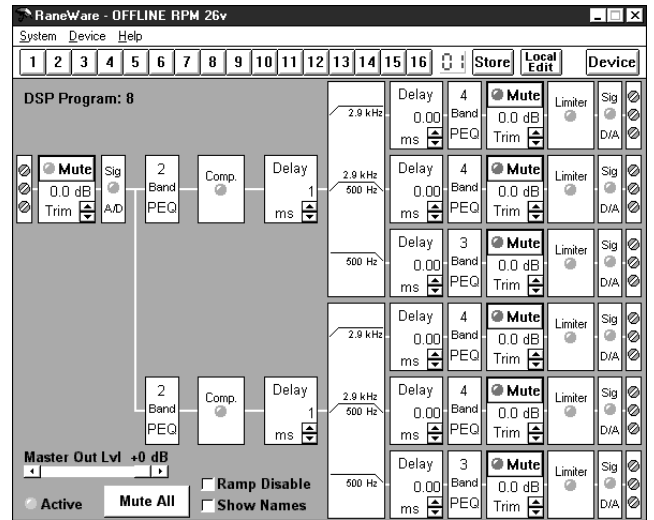

**DSP Program 8 - One Input *split* to two, 3-way Crossover System**  
 1 input, 6 outputs; 26 bands of PEQ.  
 DSP clone of Rane "AC 23 with 1 input connected" plus the rest of your system's needs!!

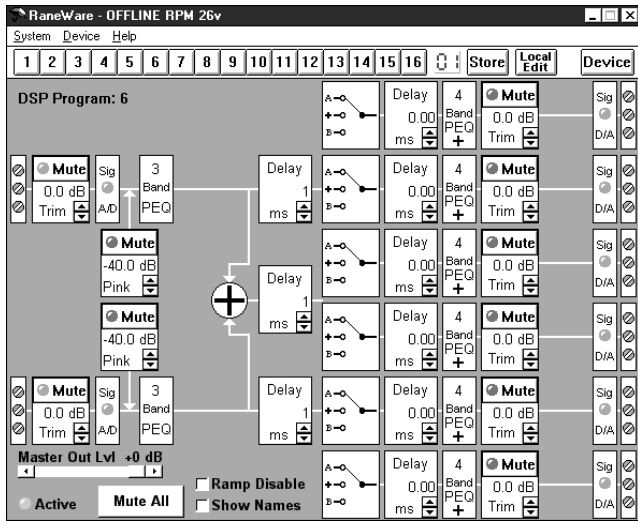

**DSP Program 6 - 2 x 6 Matrix Router System**  
 2 inputs, 6 outputs; 30 bands of PEQ; Includes *PEQ+* for up to 6-way crossovers. Each output may select A, B, or A+B source input. Pink noise or sine wave generator.

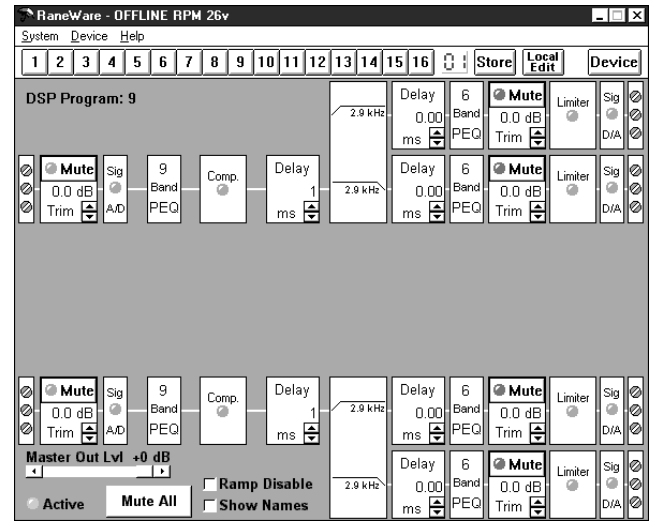

**DSP Program 9 - Dual 2-way Crossover System**  
 2 inputs, 4 outputs; 42 bands of PEQ! Most PEQ bands on *inputs* (see DSP Program 3).  
*Still very cost effective compared to other similar systems!*

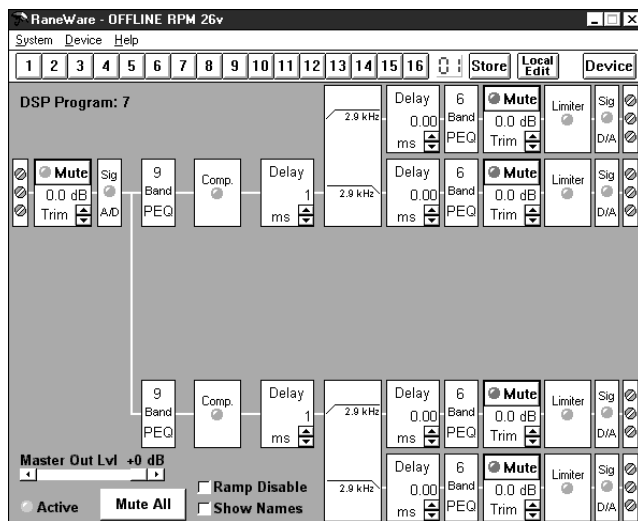

**DSP Program 7 - One Input *split* to two, 2-way Crossover System**  
 1 input, 4 outputs; 42 bands of PEQ.  
 DSP clone of Rane "AC 22 with 1 input connected" plus the rest of your system's needs.

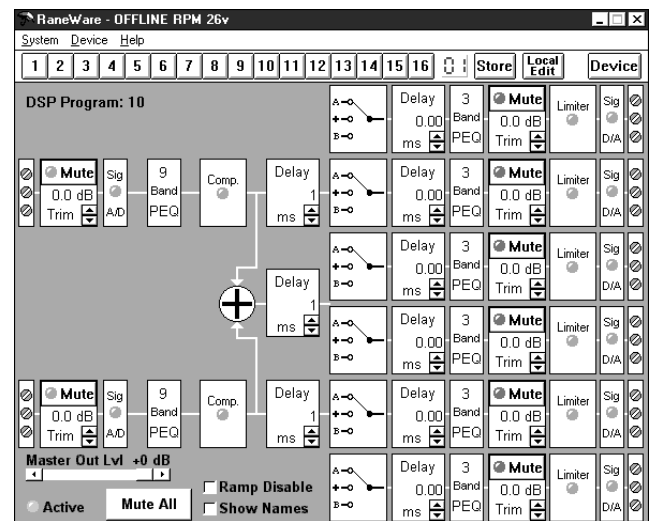

**DSP Program 10 - 2 x 6 Matrix Router System**  
 2 inputs, 6 outputs; 36 bands of PEQ! Most PEQ bands on *inputs* (see DSP Program 11).  
 All outputs independently "input switchable." Great for distribution applications.

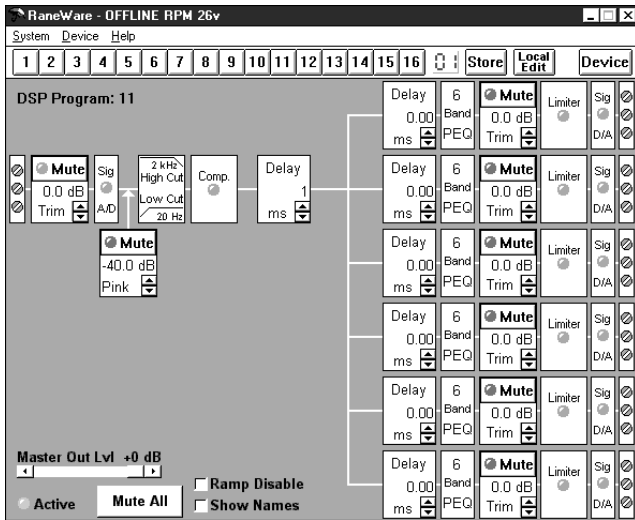

**DSP Program 11 - 1 x 6 Matrix Router System**

1 input, 6 outputs; 36 bands of PEQ, *plus* high & low cut filters on each input. All PEQ bands on *outputs* (see DSP Program 10). Pink noise or sine wave generator.

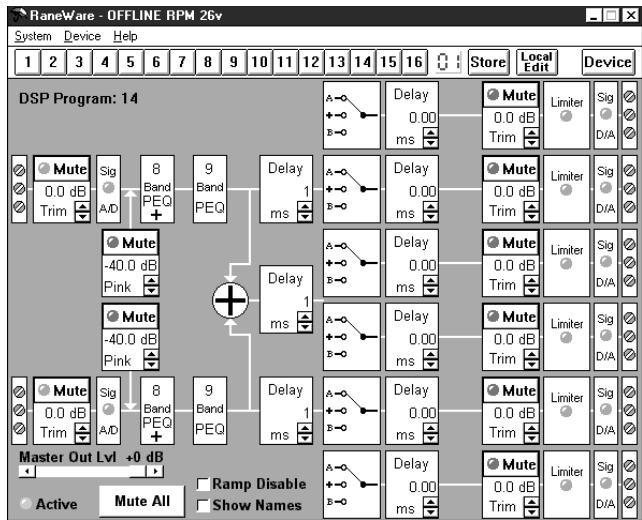

**DSP Program 14 - 2 x 6 Matrix Router System with "Sublime" PEQ**

2 inputs, 6 outputs; 34 bands of PEQ with extended PEQ+. Each output independently mono-able or "input switchable." Pink noise or sine wave generator.

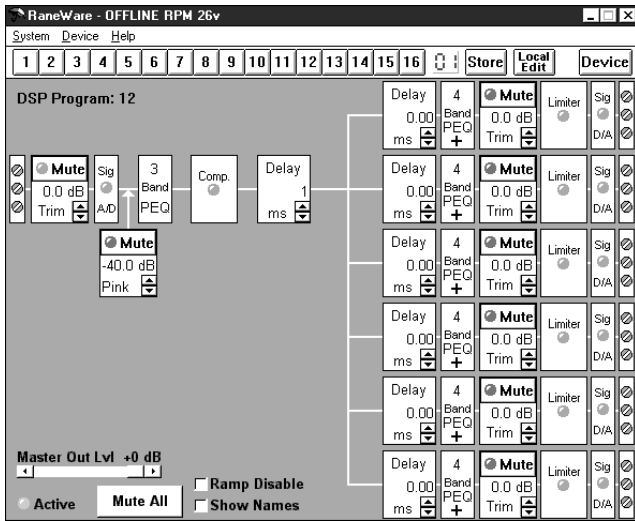

**DSP Program 12 - 1 x 6 Matrix Router System with Extended PEQ+**

1 input, 6 outputs; 27 bands of PEQ; *includes* extended PEQ on outputs! Includes PEQ+ for up to 6-way crossovers or 5-way with subwoofer output. Pink noise or sine generator.

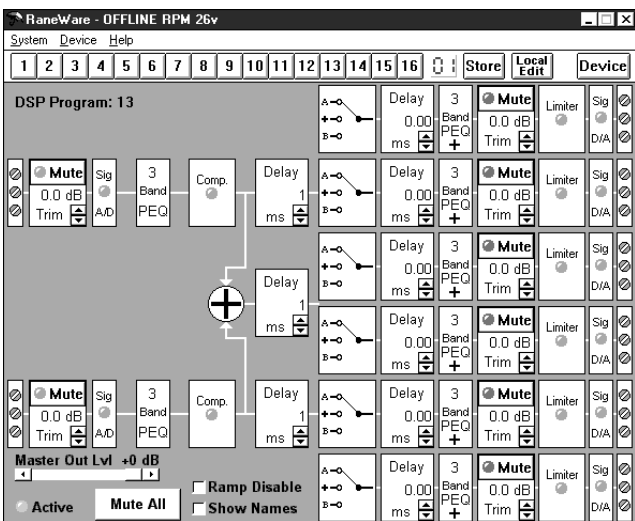

**DSP Program 13 - 2 x 6 Matrix Router System with Extended PEQ+**

2 inputs, 6 outputs; 24 bands of PEQ; includes PEQ+ on outputs. Includes PEQ+ for 6-way crossover, or 4-way with stereo subwoofers, or 4-way with two full range Outputs. Data Sheet-4

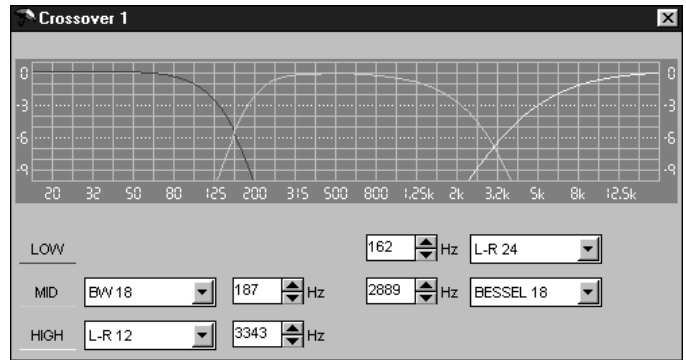

Double-clicking on a 3-way Crossover block opens the 3-way Crossover detail window. Right-clicking again opens the Advanced Mode Crossover window shown above.

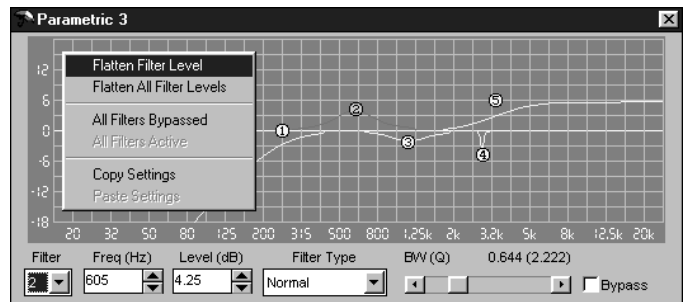

Double-clicking on a PEQ block opens the Parametric detail window. Right-clicking allows Flatten, Bypass, or Copy/Paste functions.

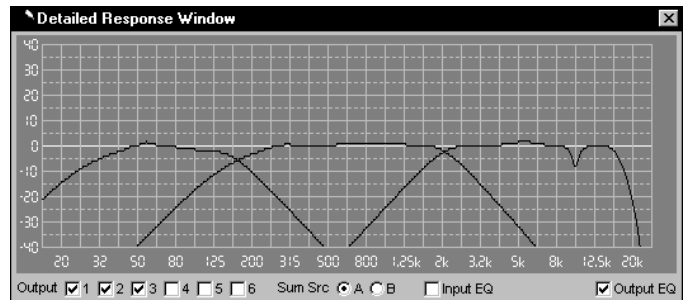

Double-clicking on an Output terminal block opens the Detailed Response window. Input and Output EQ, Crossovers, and individual Output responses may be viewed and printed.

### Features and Specifications

Parameter	Specification	Limit	Units	Conditions/Comments
Gain	0.0	±0.5	dB	Level controls at unity gain
Frequency Response	20 Hz to 20 kHz	+0/-1	dB	
THD + Noise	<0.01	.005	%	+4 dBu, 1 kHz
Dynamic Range	102	min.	dB	A-weighted, re +20 dBu, 20-20 kHz
IM Distortion (SMPTE)	<0.01	.01	%	60 Hz / 7 kHz, 4:1, + 4 dBu
Propagation Delay	1.5	1%	msec	Displayed in software delay times
Crosstalk	-100	typ.	dB	1 kHz bandpass, any Channel
Inputs: Type	Active Balanced			Optional line level isolation transformers available
.....Connectors	Euroblock			Shields are chassis grounded
.....Impedance	10k each leg	1%	ohms	
.....Maximum Level	20	1	dBu	
.....Common Mode Rejection	>46	1	dB	20 Hz to 20 kHz
.....Signal Present	-20	2	dBu	at 1 kHz
.....Overload	17	2	dBu	at 1 kHz; 3 dB before clipping
Outputs: Type	Active Balanced			
.....Connectors	Euroblock			Shields are chassis grounded
.....Impedance	100 each leg	1%	ohms	
.....Maximum Level	20	1	dBu	2k ohms load
.....Signal Present	-20	2	dBu	at 1 kHz
.....Overload	17	2	dBu	at 1 kHz; 3 dB before clipping
Input Trim Range	+31.5 to -12	0.15	dB	Minimum ½ dB steps
Output Trim Range	0 to -30	0.01	dB	Minimum ½ dB steps
Master Output Range	0 to -64	0.01	dB	Minimum 1 dB steps
Input & Output RFI Filters	Yes			
A/D Converters	24 bit			50 kHz sample rate
Processing	24 bit and higher			
Communications Interface	RW 232 (RS-232)			
.....Cable Length	50 feet maximum			15 meters maximum
Memory	NOVRAM			<i>Non-volatile, no batteries</i>
.....Change Update Time	65	avg.	msec	90 msec max., DSP Program dependent
<b>High &amp; Low Cut Filters</b>	Fixed 4th Order			24 dB / octave, Butterworth
.....Low Cut Filter Freq. Range	20 to 12,800	typ.	Hz	Minimum step size 1 Hz
.....High Cut Filter Freq. Range	31 to 20,000	typ.	Hz	Minimum step size 1 Hz
<b>Pink Noise Type</b>	Pseudo Random (average)			½ dB error
.....Pink Noise Period	167	typ.	sec.	
.....Crest Factor	4.9	typ.		
<b>Sine Wave Generator</b>	20 to 20,000		Hz	1 Hz steps
				Channel 1 and Channel 2 generators are phase incoherent

Note: unless otherwise noted, all settings "flat," Thresholds set at minimum, Ratios set at maximum

Continued...

## RPM 26v Features and Specifications

Parameter	Specification	Limit	Units	Conditions/Comments
<b>Parametric EQ (PEQ) &amp; Extended Parametric EQ (PEQ+)</b>				
.....Center Frequency Range	20 to 20,000	typ.	Hz	Number of filters varies with loaded DSP Program Minimum step size 1 Hz
.....Normal Filter Level Range	+12 to -15		dB	¼ dB steps
.....Shelving Filter Level Range	+12 to -15		dB	¼ dB steps
.....Bandwidth Range [BW (Q)]	0.036 to 2.54		octave	Q of 40 to 0.5 respectively, 80 steps total
<b>Extended Parametric (PEQ+) &amp; Crossover Filter Types</b>				
.....Bessel Corner Frequency				Attenuation at frequency selected
2nd Order	-4.5		dB	
3rd Order	-6.25		dB	
4th Order	-7.5		dB	
.....Bessel Orders	2nd, 3rd & 4th			
.....Butterworth Corner Frequency	-3		dB	
.....Butterworth Orders	2nd, 3rd & 4th			12, 18 & 24 dB / octave, respectively
.....Linkwitz-Riley Corner Freq,	-6		dB	
.....Linkwitz-Riley Orders	2nd & 4th			12 & 24 dB / octave, respectively
.....Crossover Frequency Step Size	Approximately 1		Hz	
<b>Simple Crossover Mode: Frequency Range</b>				
.....2-Way	70 to 3,600		Hz	
.....3-Way, Low Output Corner	70 to 1,000		Hz	
.....3-Way, High Output Corner	190 to 7,000		Hz	
<b>Advanced Crossover Mode: Frequency Range</b>				
.....2-Way	20 to 12,500		Hz	
.....3-Way, Low Output Corner	20 to 12,500		Hz	
.....3-Way, High Output Corner	20 to 12,500		Hz	
.....3-Way, Mid Out High Corner	12,500 Maximum		Hz	
.....3-Way, Mid Out Low Corner	20 Minimum		Hz	
<b>CD Horn EQ: Frequency Range</b>	2k to 5k	typ.	Hz	+3 dB corner freq., 6 dB/octave slope
<b>Compressor</b>				
.....Threshold Range	+20 to -20	1	dB	½ dB steps
.....Ratio Range	1:1 to 20:1 & infinity:1	typ.		29 steps between 1:1 & 20:1
.....Attack Time	0.5 to 100	typ.	msec	16 steps †
.....Release Time	1 msec to 5.0 sec	typ.		15 steps †
<b>Limiter</b>				
.....Threshold Range	+20 to -20	1	dB	½ dB steps; Ratio fixed at infinity
.....Attack Time	1 to 100	typ.	msec	15 steps †
.....Release Time	1 msec to 5.0 sec	typ.		15 steps †
<b>Delay</b>				
.....Coarse Minimum Step Size	1		msec	Minimum Coarse Delay is always 1
.....Coarse Delay Range			msec	
1 Input DSP Programs	1 to 1967			
2 Inputs (no summing)	1 to 651			
2 Inputs (w/ summing)	1 to 438			
.....Fine Minimum Step Size	0.02		msec	
.....Fine Delay Range			msec	
1 Input DSP Programs	0 to 655			
2 Inputs (no summing)	0 to 650			
2 Inputs (w/ summing)	0 to 436			
.....Temperature Range	0° to 127°		F	1° (F) minimum step size
† Time for Output to settle within 1 dB of final value for a 10 dB step.				
Note: unless otherwise noted, all settings "flat," Thresholds set at minimum, Ratios set at maximum				

Continued...

### Features and Specifications

Parameter	Specification	Limit	Units	Conditions/Comments
<b>Unit: Agency Listing</b> .....230 VAC model	UL 813 and CSA Exempt FCC Part 15J CE-EMC CE-Safety			Class 2, National Electrical Code Certified Class B Device EMC directive 89/336/EEC Per Article 1 of LVD 73/23/EEC
<b>Power Supply: Agency Listing</b> .....120 VAC model .....230 VAC model	RS 3 (see data sheet) UL CSA CE-EMC CE-Safety			Class 2 Equipment File No. E132267 File No. LR57450-99 EMC Directive 89/336/EEC LVD 73/23/EEC
Power Supply Input <b>Unit: Construction</b>	85 to 265 All Steel		VAC	IEC line cord jack
.....Size	1.75" H x 19" W x 8.5" D			1U (4.4 cm x 48.3 cm x 21.6 cm)
.....Weight	5 lb (w/o power supply)			(2.3 kg)
<b>Shipping: Size</b>	4.5" x 20.3" x 13.75"			(11.5 cm x 52 cm x 35 cm)
.....Weight	9 lb			(4.1 kg)
<i>Note: 0 dBu = 0.775 Vrms</i>				

### RPM 26v Block Diagram

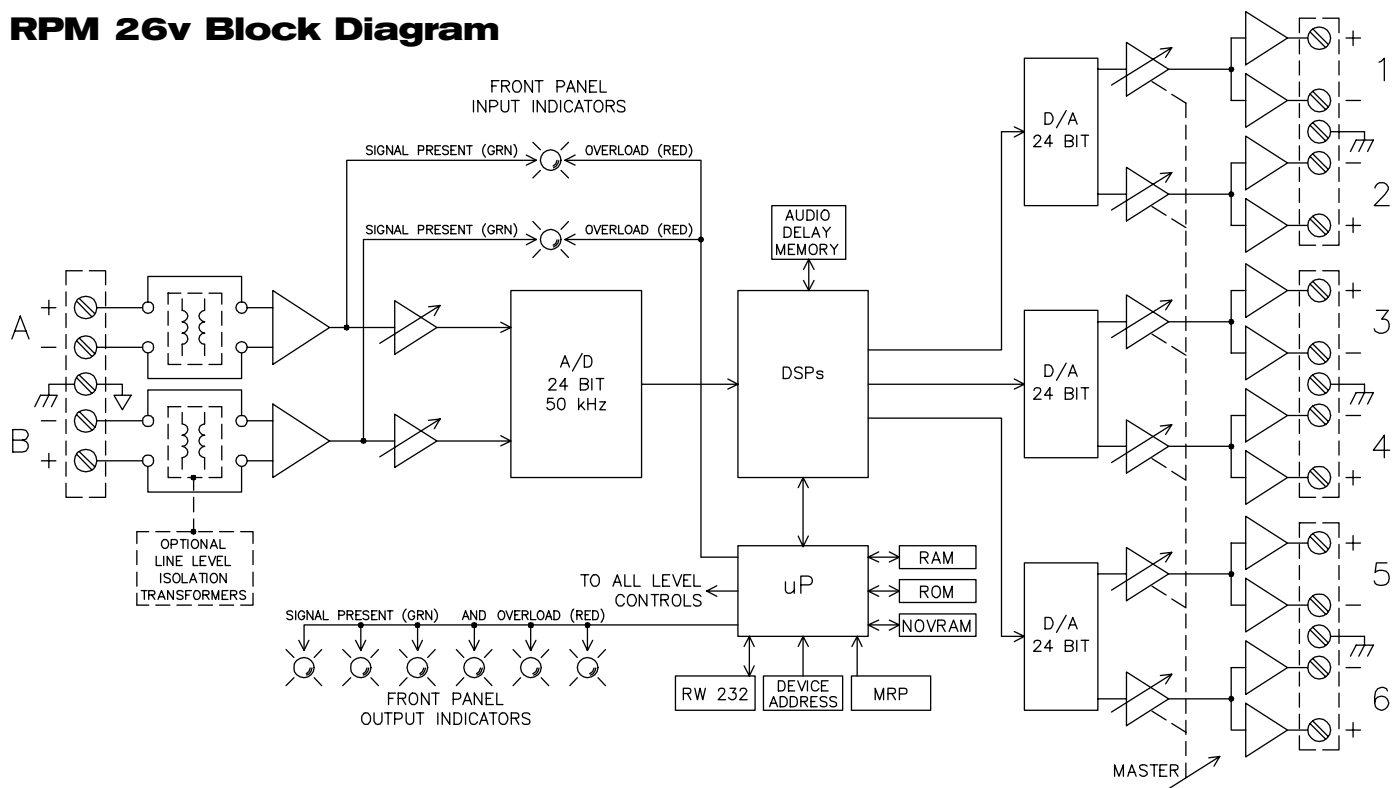

# RPM 26v

## DSP MULTIPROCESSOR



### Rear Panel

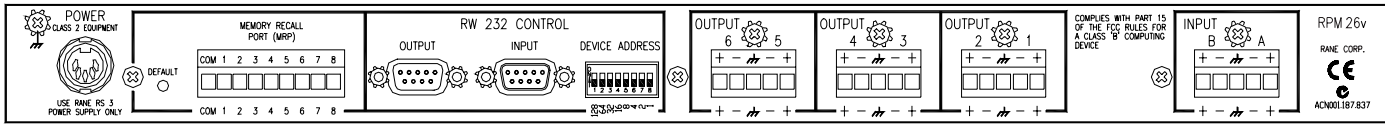

### Architectural Specifications

The signal processor shall provide two analog inputs and six analog outputs. Data conversion shall be 24-bit with a minimum 100 dB dynamic range. A variety of pre-programmed signal processing configurations shall be available utilizing internal digital signal processing algorithms. There shall be a wide variety of signal processing functions including varying combinations of:

- High & Low Cut Filters
- Compression
- Delay
- Crossover
- Parametric EQ
- Splitting
- Summing
- Limiting
- Input and Output Trim
- Pink noise or sine wave Generation

The fixed signal processing configurations shall be programmable from PC compatible, Windows® software. The unit shall have no front panel controls. There shall be 16 internal, non-volatile memories for storing settings for later recall via a dedicated on-site computer or via other RS-232 compatible means. Contact closure recall of the memories shall be provided via a rear panel Euroblock connector, making the computer optional once programmed. Contact closure ports shall be parallelable for recalling the same memory in multiple units. Each memory may contain a unique signal processing configuration. A recessed, rear panel default switch shall provide recall of Memory 1 in case of computer failure. All processing settings shall always be stored in non-volatile memory inside the unit, thus allowing computer failure without losing settings.

Active balanced analog inputs and outputs shall be accessible via rear panel Euroblock connectors. Signal processing configurations and settings shall be accessible via a rear panel RS-232, DB-9 input port. Up to 16 units at a time shall be daisy-chained via a rear panel RS-232 output port. The rear panel device address switch shall uniquely identify each unit on the RW 232 bus.

The front panel shall provide independent input and output, dual-color signal present (green) and overload (red) indicators. Level indicators shall provide throughput signal flow verification without need for a computer. There shall be front panel power and communications indicators.

The control software shall provide complete display and control, in graphical form, of all signal processing configurations and functions. Most signal processing settings shall be displayed from a single computer screen. All settings shall be accessible via dialog boxes and printable in device reports. There shall be means to backup all settings to a computer file for later recall or editing. Graphical plots of the calculated frequency response of each processing function and an overall response plot shall be provided.

The unit shall have certified compliance with FCC Part 15J for a Class B computing device and EMCD 89/336/EEC (CE approved). The unit shall be powered from a UL listed, CSA certified remote power supply meeting LVD 73/23/EEC and EMCD 89/336/EEC standards. The unit shall be constructed entirely of cold-rolled steel.

*The unit shall be a Rane Corporation RPM 26v DSP Multiprocessor.*

### Accessory Available:

#### Input Isolation Transformers (Rane part #00961)

Parameter	Specification	Limit	Units	Conditions/Comments
Optional Input Line Transformer	Nickel Core Bobbin Wound			Grade "80" Ni. transformer specs
.....Impedance	20 source, 10k load		ohms	
.....Turns Ratio	1:1			Primary to secondary
.....40 Hz Max Level	20	0.5 dB	dBu	1% THD point
.....20 Hz Max Level	18.5	0.5 dB	dBu	1% THD point
.....Load Loss	0.5	0.1	dB	
.....DC Resistance	200	10%	ohms	Primary / secondary
.....Frequency Response	20 Hz to 20 kHz	0.1	dB	+4 dBu
.....Bandwidth	60 kHz	-3	dB	Half power frequency
.....THD + Noise	<0.005	0.001	%	+20 dBu; 100 - 20 kHz
	<0.15	0.05	%	+20 dBu; 30 - 20 kHz