

General Description

Equal parts problem solver, creative tool and secret weapon, Rane’s dual channel PEQ 55 features five bands of fully parametric equalization, adjustable high-cut and low-cut filters, and three-band Accelerated Slope™ tone controls per channel. Front panel controls select between dual mono 5-band, mono 10-band, and stereo linked 5- or 10-band operating modes. Analog ease of use combined with high performance digital technology make the PEQ 55 ideal for professional sound reinforcement, fixed installation, broadcast and recording applications.

The PEQ 55 is a member of Rane’s analog-controlled digital family of products, which includes the AC 24 crossover, DEQ 60 / 60L graphic equalizers, C4 compressor and the G4 gate.

Features

- Each channel: 5 bands of fully parametric equalization (all bands overlapping 20 Hz to 20 kHz), adjustable high- and low-cut filters, and 3-band Accelerated Slope tone controls.
- Multiple configurations {
 - Dual mono 5-band operation.
 - Mono 10-band operation.
 - Stereo linked 5- or 10-band operation.
- Individual filter overload indicators.
- Bypass individual filters or all filters per channel.
- Input and Output Level controls and metering.
- XLR, ¼" TRS and Euroblock input/output connectors.
- Universal internal switching power supply.

Analog-Controlled Digital

For years, analog parametric equalizers have been the preferred tool in applications ranging from corrective equalization in sound reinforcement systems to creative equalization in live sound, broadcast and recording. Analog controls (knobs, sliders) allow a performer or sound engineer to make precise adjustments, in real time. Digital signal processing (DSP) provides a degree of accuracy, consistency and flexibility that simply can not be matched with a traditional analog design.

The PEQ 55 combines the best of both worlds by using analog controls and high performance digital processing to achieve an unprecedented feature set. Benefits of this approach:

- The ability to easily A/B two EQ curves
- The ability to link channels
- Improved accuracy and repeatability
- Exceptional immunity to RF and electromagnetic interference
- Lower cost per filter.

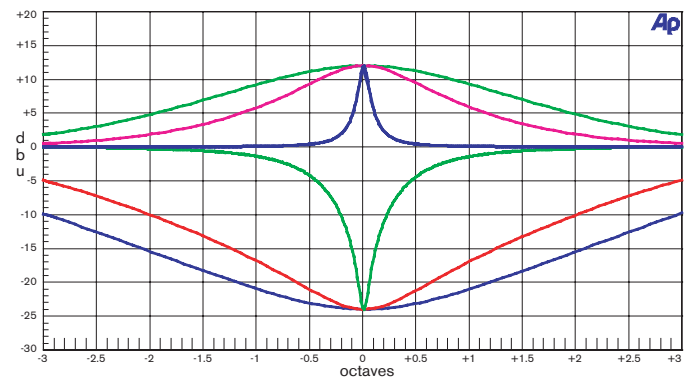

Figure 1. Graphic response of various bandwidths, boost and cut.

PEQ 55

PARAMETRIC EQUALIZER

Features and Specifications

Parameter	Specification	Limit	Units	Conditions/Comments
Inputs: Type	Active Balanced			
.....Connectors	XLR, ¼" TRS, Euroblock			XLR pin 2 hot per AES standards
.....Maximum Input	+22	1	dBu	1 kHz
.....Common Mode Rejection	60	typ.	dB	1 kHz
.....Impedance	10.0k	1%	Ω	Each leg to ground @ 1 kHz
Outputs: Type	Active Balanced			
.....Connectors	XLR, ¼" TRS, Euroblock			XLR pin 2 hot per AES standards
.....Impedance	100	1%	Ω	Each leg to ground
.....Maximum Output	+22	1	dBu	600 Ω or greater
EMI Filters	Yes			Inputs and Outputs
Frequency Response	15 Hz to 20 kHz	+0/-3	dB	
THD+Noise	.02	typ.	%	+4 dBu, 20-20 kHz, 20 kHz BW
THD+Noise	.006	typ.	%	+4 dBu, 1 kHz, 20 kHz BW
Crosstalk	<-100	typ.	dB	2 kHz
DSP Block				
24-bit Converters: Sample Rate	48		kHz	
.....Dynamic Range	106	typ.	dB	A-weighted (input to output); unity
Propagation Delay	1.29	typ.	ms	
Input Level: Range	±12		dB	
Output Level: Range	±12		dB	
High Shelf Filters	12.5 Hz to 20 kHz		Hz	2nd-order
Low Shelf Filters	25 Hz to 20 kHz		Hz	2nd-order
Parametric Filters:				2nd-order, overlapping
.....Frequency Range	12.5 Hz to 12 kHz		Hz	x0.1, x1, x10; 4 octave multiplier
.....Bandwidth	1/12 to 2 Octaves			
.....Boost/Cut	+12 / -24		dB	
Tone Controls	3-band; <i>Accelerated Slope</i> [™]			2nd-order, phase 0° @ unity gain
.....Range	+6 to off		dB	Center detent=0 dB
.....Low/Mid Crossover Point	300		Hz	
.....Mid/High Crossover Point	4		kHz	
Low-Cut Filter	15-240		Hz	
High-Cut Filter	5-20		kHz	
Meters	Input and Output			Each channel
.....Type	Peak responding		dBu	Peak-dBu is displayed for 1.5 sec
.....Attack/Decay	0/500	typ.	ms	per 20 dB step
Bypass:Power Failure	Automatic relay bypass			Input wired to Output
Bypass Switch Mode				Each channel
.....Rear switch:Bypass All	Filters and Levels bypassed			By front panel bypass
.....Rear switch:Bypass Filters	Filters bypassed only			By front panel bypass
A/B Switches	Determine controls to channel			Bypass and A/B not affected
Unit: Power Supply Requirement				100 to 240 VAC, 50/60 Hz, 20 W
.....Agency Listing				UL/cUL/CE
.....Construction	All Steel			
.....Size	3.5" H x 19" W x 8.25" D (2U)			(8.9 cm x 48.3 cm x 21 cm)
.....Weight	7.3 lb			(3.3 kg)
.....Shipping: Size	4.5" x 20.3" x 13.75"			(11.5 cm x 52 cm x 35 cm)
.....Shipping: Weight	12 lb			(5.5 kg)
<i>Note: 0 dBu=0.775 Vrms</i>				

Block Diagram

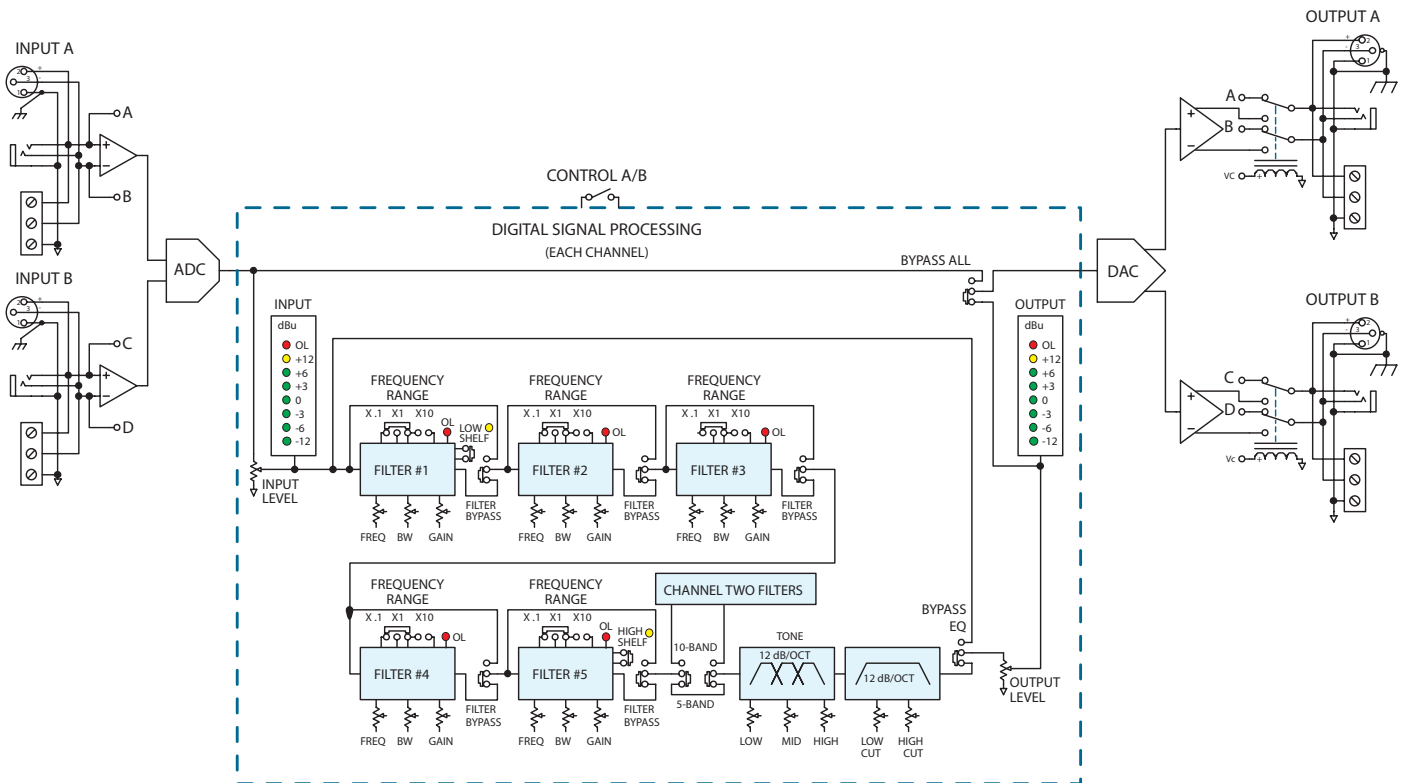

Architectural Specifications

The equalizer shall be analog-controlled, with all controls provided on the front panel. All signal processing shall be accomplished using high accuracy digital signal processing.

The equalizer shall consist of two channels of 5 frequency bands each. It shall be configurable as a dual mono 5-band, mono 10-band, or stereo linked 5- or 10-band equalizer. The equalizer shall feature analog-style control of advanced digital signal processing (DSP). A/B switches for curve comparison or stereo linking shall be provided.

Gain for each equalizer band shall be adjustable from -24 dB to +12 dB. All frequency bands shall be fully overlapping and adjustable from 12.5 Hz to 20 kHz with a x0.1, x1 or x10 frequency multiplier. Bandwidth shall be continuously adjustable from 1/12 to 2 octaves. Filter bands one and five of each channel shall include a switchable low and high shelving response, respectively. When 10-band mode is selected only band one of the first channel and band five of the second channel shall be switchable to shelving response.

Low and high cut filters shall be provided with 12 dB/ octave slopes and adjustable corner frequencies. Tone controls shall be provided for Low, Mid and High frequencies. The tone controls shall have a range of +6 dB to off.

The unit shall provide an automatic relay bypass feature when power is not available, and active bypass switches for each channel when the unit is operating. Active bypass mode shall be switchable to bypass all controls, including input and output levels, or just the filter section.

Input and Output Level controls and peak dBu meters shall be provided for each channel. All inputs and outputs shall be RFI filtered, active balanced designs terminated with XLR, ¼" TRS (tip-ring-sleeve), and Euroblock terminals.

The unit shall meet CE and UL agency safety requirements and be powered from an internal universal power supply (100 to 240 VAC) via a rear panel IEC connector. The unit enclosure shall be constructed entirely from cold-rolled steel. The unit shall be supplied with ears for mounting into a standard 2U EIA rack.

The unit shall be a Rane PEQ 55 Parametric Equalizer.

PEQ 55

PARAMETRIC EQUALIZER



Rear Panel

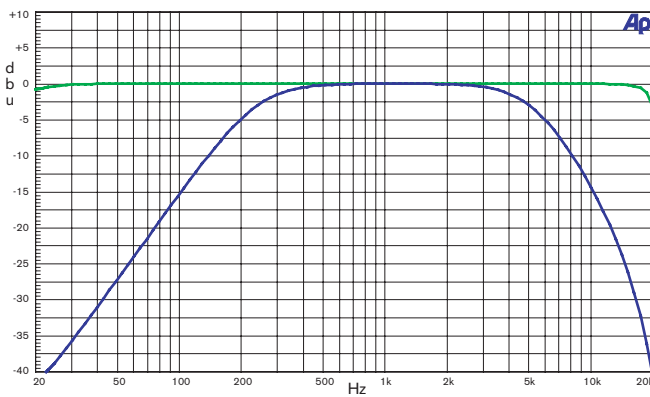
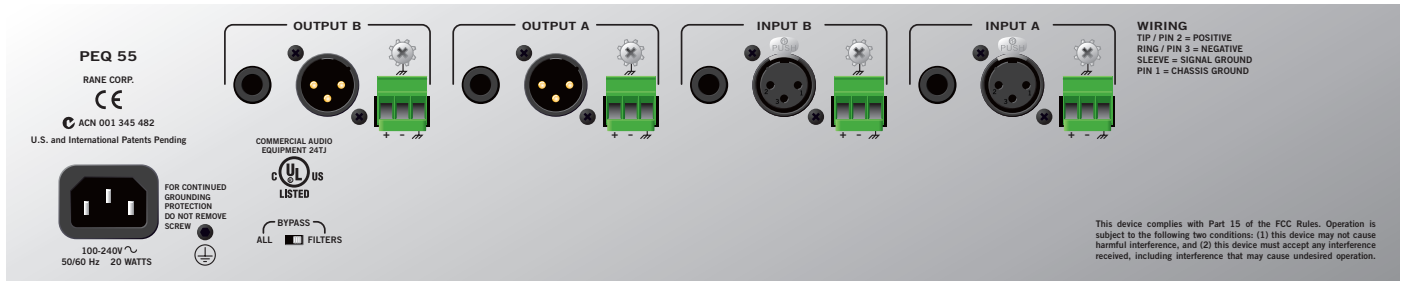

Figure 2. Low and High Cut filter response.

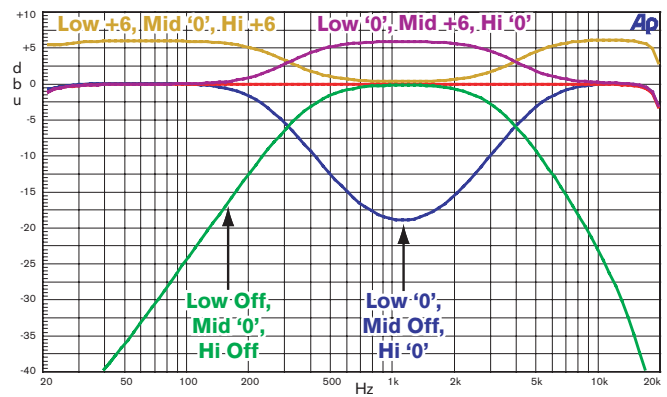

Figure 3. Tone control response.

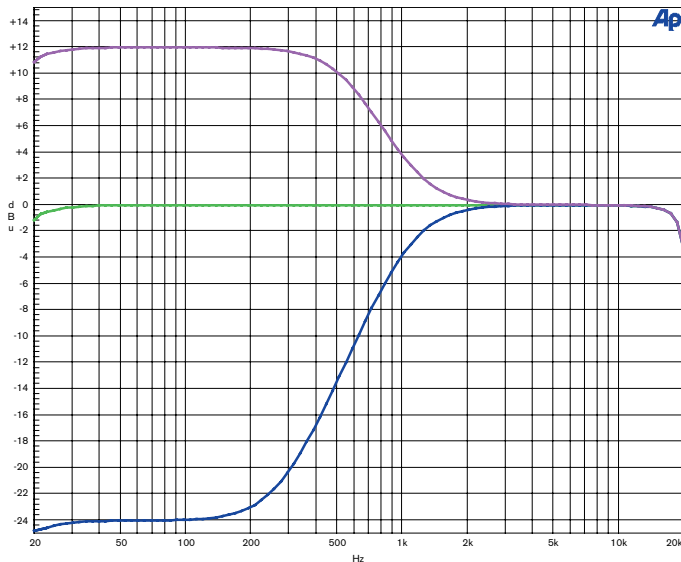

Figure 4. Low Shelf Filter response.

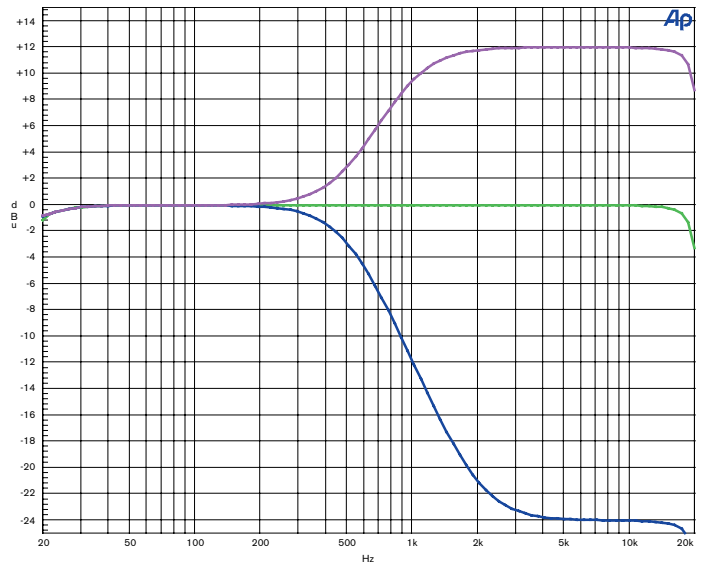

Figure 5. High Shelf Filter response.

Accessories

- Optional SC 5.2 Security Cover