

General Description

The Rane MS 1b Mic Stage preamplifier provides the answer when you need just one microphone input in an otherwise line-level world. Give us a call to go from either a dynamic, condenser or electret microphone to a line-level input with a minimum of noise, distortion, cost and hassle.

The MS 1b provides 48 V switchable Phantom Power with indicator LED, continuous rotary Gain trim between 18 dB and 66 dB, Signal/Overload LED, and XLR balanced Input & Output connectors. A Polarity switch and high-current cross-coupled output line driver round out the features.

The MS 1b utilizes one of the finest ultra low noise amplifier designs available. Featuring a true differential input with high common-mode rejection, use of the MS 1b guarantees performance usually found only in mixing consoles costing thousands of times as much. Of course, for all of that extra money you receive a proportional increase in KPSI (knobs per square inch).

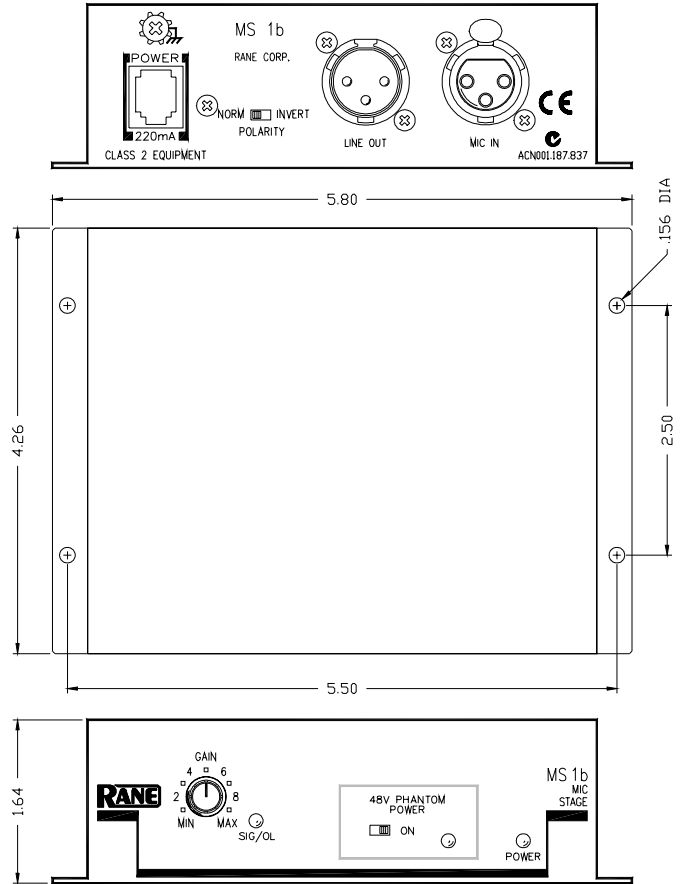

Features

- *New! Improved Max Input*
- *New! Improved dynamic range*
- Gain control
- Signal and Overload indicators
- Polarity switch
- Switchable 48 V Phantom Power
- Ultra low-noise design
- True differential Input
- Cross-coupled line driver
- UL/CSA/CE and 100/120/230 VAC remote power supply



Features and Specifications

Parameter	Specification	Limit	Units	Conditions/Comments
Input Impedance	10k	1%	ohms	Balanced 5k + 5k
Gain Range	18 to 66	typ.	dB	
Phantom Power	+48	4%	volts	10 mA max.
.....Impedance	6.81k	1%	ohms	Each leg
.....Load Regulation	0.1	typ.	%	0 to 14 mA
.....RMS CM Noise	.003	typ.	%	% of Vout (10 to 10k Hz)
Max. Input Level	+10/-32	min.	dBu	Gain 18/60, balanced output
Equivalent Input Noise	-128	typ.	dBu	20 kHz BW, Rs=150 ohms, Gain = 60 dB
Signal to Noise Ratio	96	typ.	dB	20 kHz BW, Rs=150 ohms, Gain = 18 dB, re 4 dBu
Dynamic Range	120/95	typ.	dB	Gain 18/66
CMRR	80	typ.	dB	Rs=150 ohms, 120 Hz, Gain = 60 dB
Frequency Response				
.....Gain 60 dB	45 to 200k	typ.	Hz	+0, -3dB
.....Gain 18 dB	30 to 200k	typ.	Hz	+0, -3db
THD+Noise (gain 60 dB)	.007 (Output=+20 dBu)	typ.	%	55 to 20k Hz, 20 kHz BW, Rl=10k ohms
THD+Noise (gain 18 dB)	.001 (Output=+20 dBu)	typ.	%	50 to 20k Hz, 20 kHz BW, Rl=10k ohms
Line Driver	Active Cross-coupled			Gain 5.2/6 dB typ. unbalanced/balanced
Max. Output Level	+22/+27	min.	dBu	Unbalanced/balanced, 2k ohm load
Output Impedance	50	1%	ohms	Each Leg
Signal Indicator	2/8	typ.	dBu	Unbalanced/balanced output, Green LED
Overload Indicator	14/20	typ.	dBu	Unbalanced/balanced output, Amber LED
Output Cable Length	300	typ.	meters	Belden 8451 or equivalent
Unit: Agency Listing				
.....120 VAC model	Class 2 Equipment UL & CSA			National Electrical Code Exempt Class 2 equipment
.....230 VAC model	CE-EMC CE-Safety			EMC directive 89/336/EEC Exempt per Art. 1, LVD 73/23/EEC
Power Supply: Agency Listing				
.....120 VAC model	UL CSA			Class 2 Equipment File no. E88261
.....230 VAC model	CE-EMC CE-Safety			File no. LR58948 EMC directive 89/336/EEC LV directive 73/23/EEC
.....100 VAC model	Built to JIS			Japan only
Power Supply Input	18 VAC w/center tap	10%	Vrms	Rane RS 1 supplied
Max Current Consumption	220		mA	
Unit Size	1.65" H x 5.1" W x 4.25" D			(4.2 cm x 13 cm x 10.8 cm)
.....Weight	1 lb			(0.45 kg)
Shipping Size	3.6" H x 11.75" W x 7.2" D			(9.5 cm x 30 cm x 18 cm)
.....Weight	4 lb			(1.8 kg)

Block Diagram

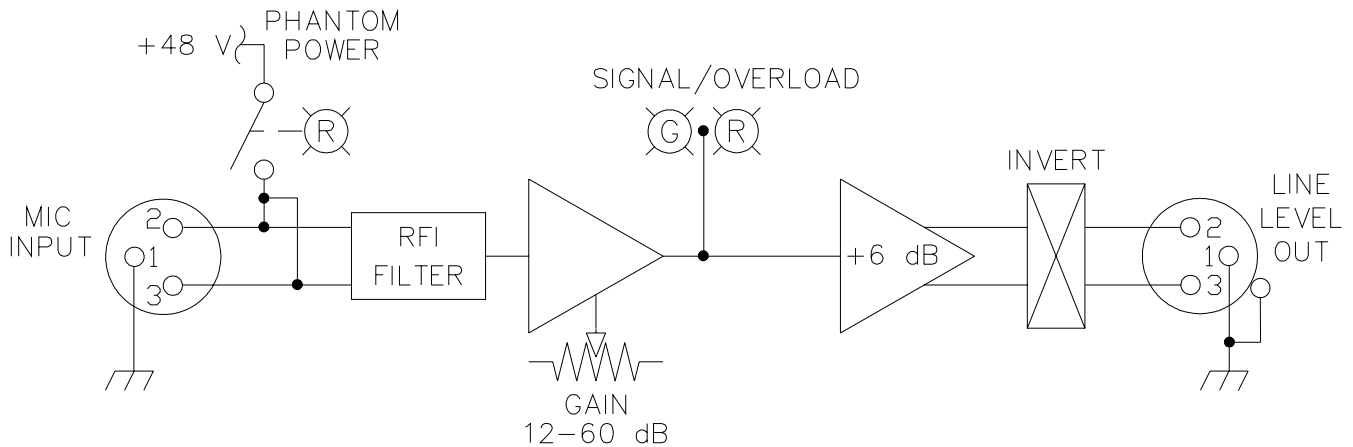

Application Information

Uses and applications for the MS 1b should be obvious. But then again, it's obvious to us our taxes are too high and nothing is being done about that. With this in mind, perhaps a few words on using the MS 1b might not be wasted.

BALANCED USE

The MS 1b provides a true cross-coupled balanced output. This is equivalent to an electronic simulation of a transformer output. Rane follows the AES standard of pin 2 = hot.

When running a long cable back to the mixer, run a *line-level* balanced line rather than a mic-level line. The compact MS 1b can mount closer to the microphone, provide a local volume control (or not, just pull the knob off), while the stronger signal minimizes RF and hum irritations.

UNBALANCED USE

Balanced use is recommended to minimize noise. When you must drive an unbalanced device with the MS 1b's balanced output, connect pin 2 to the "+" or "hot" lead, and *tie pin 3 and ground together at the shield.*

MIXING

The MS 1b is designed to fill the need for adding a microphone channel to line-level mixers, such as the Rane SM 26B or SM 82. Many installations using either of these products invariably wind up with one unused input that would do the job perfectly if only it could operate at mic-level. In rides the MS 1b to the rescue.

DIGITAL RECORDING AND SAMPLING

Another handy use for the MS 1b is in recording applications. Many popular products do not have a high enough quality mic preamp to suit the resolution of the digital processing electronics. Such irony. Using the ultra low noise MS 1b to bring the mic inputs up to extremely high quality line-level is an easy and affordable solution for this dilemma. No garbage in; no garbage out. *Clippity-clop; clippity-clop.*

MICROPHONE TYPES

The available gain and large input range of the MS 1b allows the use of virtually any type of microphone. True 48V phantom power guarantees the MS 1b works with every microphone. The better the mic, the better the MS 1b sounds.

Ah, the sound of the thundering hoofs is deafening.

Architectural Specifications

The microphone preamplifier shall be a single channel stand-alone unit with remote power supply. The power supply shall be U.L. listed, C.S.A. certified, and CE certified. The input and output shall be fitted with XLR connectors. A polarity inverting switch shall be included. Phantom power shall be provided in compliance with IEC 60268-15 and be controlled by a slide switch with an LED indicator. A gain control shall be provided with 18-66 dB adjustment range. Power, system signal and overload indicators shall be provided. High current cross-coupled active output line driver shall be standard, as well as input RFI filter protection.

The unit shall be a Rane MS 1b Microphone Stage.

CHASSIS GROUNDING

Units with outboard power supplies do not ground the chassis through the line cord. Make sure that these units are grounded either to another chassis which is earth grounded, or directly to the grounding screw on an AC outlet cover by means of a wire connected to a screw on the chassis with a star washer to guarantee proper contact.

Please refer to RaneNote 110, "Sound System Interconnection" (supplied in your manual and available on request separately) for further information on system grounding.