

OPERATORS MANUAL

MQ 302

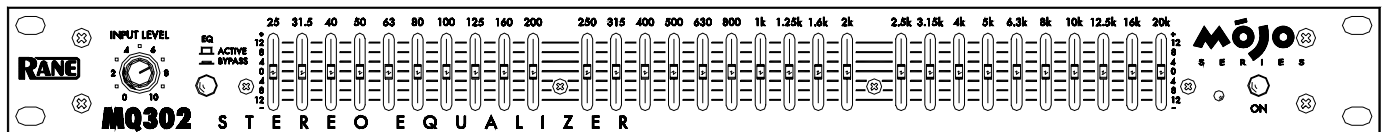

STEREO GRAPHIC EQUALIZER

QUICK START

If this is your first equalizer, please do yourself and your speakers a favor and read at least the first five pages. “An ounce of prevention...,” and all that.

The MQ 302 is a stereo equalizer, so adjusting any slider affects both Channels simultaneously. Begin by setting all sliders to their center detent (0 dB), and the **INPUT LEVEL** to **8**. Try to make more cuts than boosts. After equalizing, use the EQ switch to compare equalized and non-equalized signal. While **EQ** is switched to **ACTIVE** (*out*), adjust the **INPUT LEVEL** to the same level as when **EQ** is switched to **BYPASS** (*in*).

You may use either the XLR or ¼" connectors for Inputs or Outputs. Connect only one **INPUT** type per channel. The XLR and ¼" TRS inputs do not sum. You may, however, use both types of **OUTPUTS** simultaneously if desired.

IMPORTANT SAFETY INSTRUCTIONS



1. Read these instructions.
 2. Keep these instructions.
 3. Heed all warnings.
 4. Follow all instructions.
 5. Do not use this apparatus near water.
 6. Clean only with a dry cloth.
 7. Do not block any ventilation openings. Install in accordance with manufacturer's instructions.
 8. Do not install near any heat sources such as radiators, registers, stoves, or other apparatus (including amplifiers) that produce heat.
 9. Do not defeat the safety purpose of the polarized or grounding-type plug. A polarized plug has two blades with one wider than the other. A grounding-type plug has two blades and a third grounding prong. The wide blade or third prong is provided for your safety. If the provided plug does not fit into your outlet, consult an electrician for replacement of the obsolete outlet.
 10. Protect the power cord and plug from being walked on or pinched particularly at plugs, convenience receptacles, and the point where it exits from the apparatus.
 11. Only use attachments and accessories specified by Rane.
 12. Use only with the cart, stand, tripod, bracket, or table specified by the manufacturer, or sold with the apparatus. When a cart is used, use caution when moving the cart/apparatus combination to avoid injury from tip-over.
 13. Unplug this apparatus during lightning storms or when unused for long periods of time.
 14. Refer all servicing to qualified service personnel. Servicing is required when the apparatus has been damaged in any way, such as power supply cord or plug is damaged, liquid has been spilled or objects have fallen into the apparatus, the apparatus has been exposed to rain or moisture, does not operate normally, or has been dropped.
 15. The plug on the power cord is the AC mains disconnect device and must remain readily operable. To completely disconnect this apparatus from the AC mains, disconnect the power supply cord plug from the AC receptacle.
 16. This apparatus shall be connected to a mains socket outlet with a protective earthing connection.
 17. When permanently connected, an all-pole mains switch with a contact separation of at least 3 mm in each pole shall be incorporated in the electrical installation of the building.
 18. If rackmounting, provide adequate ventilation. Equipment may be located above or below this apparatus, but some equipment (like large power amplifiers) may cause an unacceptable amount of hum or may generate too much heat and degrade the performance of this apparatus.
 19. This apparatus may be installed in an industry standard equipment rack. Use screws through all mounting holes to provide the best support.
- WARNING:** To reduce the risk of fire or electric shock, do not expose this apparatus to rain or moisture. Apparatus shall not be exposed to dripping or splashing and no objects filled with liquids, such as vases, shall be placed on the apparatus.

NOTE: This equipment has been tested and found to comply with the limits for a Class B digital device, pursuant to part 15 of the FCC Rules. These limits are designed to provide reasonable protection against harmful interference in a residential installation. This equipment generates, uses and can radiate radio frequency energy and, if not installed and used in accordance with the instructions, may cause harmful interference to radio communications. However, there is no guarantee that interference will not occur in a particular installation. If this equipment does cause harmful interference to radio or television reception, which can be determined by turning the equipment off and on, the user is encouraged to try to correct the interference by one or more of the following measures:

- Reorient or relocate the receiving antenna.
- Increase the separation between the equipment and receiver.
- Connect the equipment into an outlet on a circuit different from that to which the receiver is connected.
- Consult the dealer or an experienced radio/TV technician for help.

CAUTION: Changes or modifications not expressly approved by Rane Corporation could void the user's authority to operate the equipment.

This Class B digital apparatus complies with Canadian ICES-003.

Cet appareil numérique de la classe B est conforme à la norme NMB-003 du Canada.

WARNING

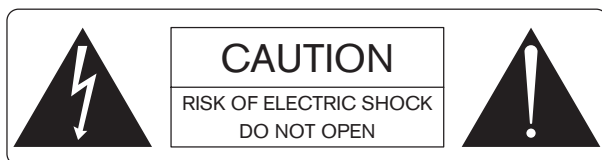

To reduce the risk of electrical shock, do not open the unit. No user serviceable parts inside. Refer servicing to qualified service personnel.

The symbols shown below are internationally accepted symbols that warn of potential hazards with electrical products.



This symbol indicates that a dangerous voltage constituting a risk of electric shock is present within this unit.



This symbol indicates that there are important operating and maintenance instructions in the literature accompanying this unit.

INPUT LEVEL control

This controls the overall level. +6 dB gain is reached at "10" with all sliders centered at 0 dB (see BYPASS switch below).

Filter level slide controls

Each of these sliders controls the output level of both Channels of the 30 bandpass filters. Center position is grounded for guaranteed flat response.

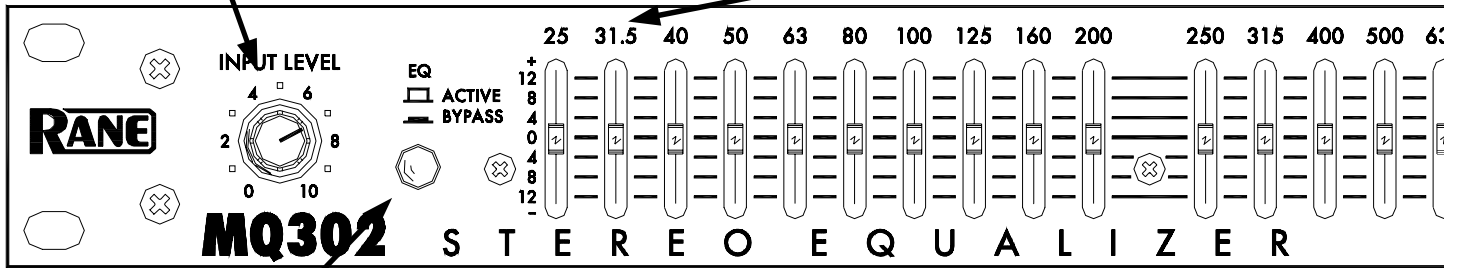

BYPASS switch

When pressed to BYPASS, the filter sliders have no effect. Since actual unity gain depends on varying slider settings, use the BYPASS switch to determine the unity gain position of the INPUT LEVEL control by comparing ACTIVE and BYPASS volumes.

Cable Wiring

In agreement with IEC and AES/ANSI standards, XLR wiring convention is pin 2 Positive (hot), pin 3 Negative (cold), and pin 1 Signal ground (for unbalanced use). Pin 1 and the connector case or shell are tied to chassis ground.

<p>MQ302</p> <p>RANE CORP.</p> <p>CE</p> <p>ACN001.187.837</p>	<p>120V~</p> <p>50/60Hz</p> <p>12WATTS</p> <p>FOR CONTINUED GROUNDING PROTECTION DO NOT REMOVE SCREW</p>	<p>CONNECTION INFORMATION</p> <p>3 PIN XLRs: PIN 1 = SHIELD, PIN 2 = POSITIVE (+), PIN 3 = NEGATIVE (-)</p> <p>1/4 INCH PHONE JACKS, UNBALANCED: TIP = HOT (SIGNAL), RING = GROUND, SLEEVE = GROUND</p> <p>1/4 INCH PHONE JACKS, BALANCED TIP = POSITIVE (+), RING = NEGATIVE (-), SLEEVE = SHIELD PLEASE REFER TO OWNERS MANUAL FOR MORE INFORMATION</p>
--	--	---

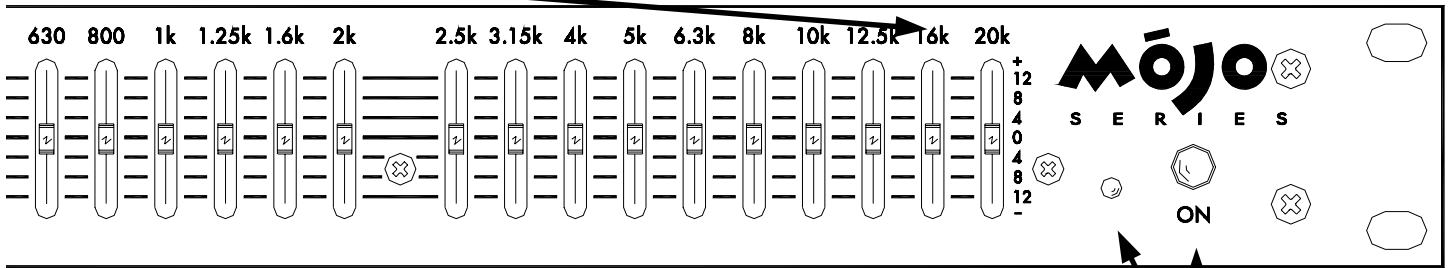

POWER switch and LED

Your basic, straightforward power switch. When the yellow LED is lit, the MC 22 is ready to go.

LEFT & RIGHT INPUTS

Choose between the balanced XLR or the balanced/unbalanced 1/4" TRS jacks, but only use one. Inserting a 1/4" TS jack will work—however—always use balanced lines especially when connecting cables over 10 feet in length. Consult SOUND SYTEM INTERCONNECTION on page Manual-8.

LEFT & RIGHT OUTPUTS

Use either the Balanced XLR or the Unbalanced 1/4" TS jacks. Using both types of Outputs are permissible to drive two devices, such as an amplifier and a recorder.

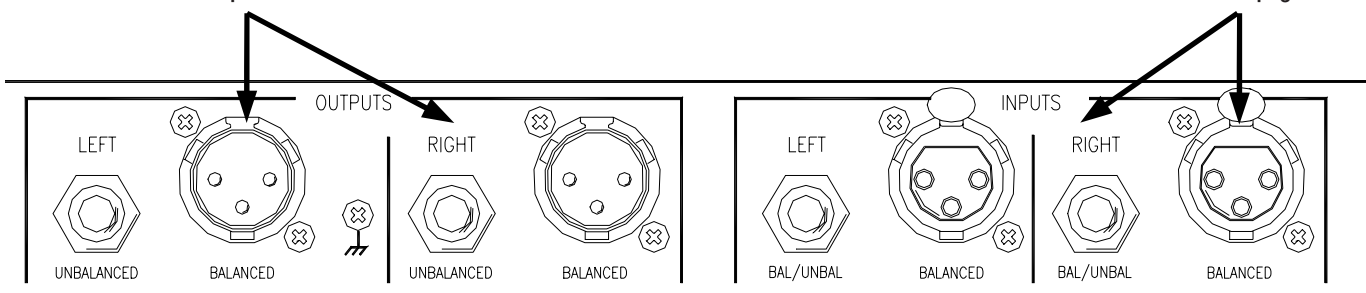

MQ 302 CONNECTION

Exactly *where* you install your MQ 302 into a sound system significantly affects such things as hum, noise, system headroom, compressor/limiter performance and other factors influencing overall sound quality. Both *what* and *why* you are equalizing determines *where* you install it. We'll leave the *when* and *who* entirely up to you.

WHAT AND WHY

Since acoustic compensation and tone contouring are two of the most common uses for equalization, here are a few words on each.

ACOUSTIC COMPENSATION

Acoustic compensation is controlled nicely with a device such as the MQ 302. The best way to “see” what room acoustics are doing to your sound is to use a real time analyzer. This test equipment lets you analyze the response of the room and the sound system and is the only accurate means available for setting an equalizer properly.

TONE CONTOURING

Contouring is accomplished mainly by ear. This you know how to do. Be careful though, not to introduce too much boost to the upper bass area (or the sub-bass area as in the last warning). Be aware that the MQ 302 is capable of boosting signals up to 12 dB (4 times as large!)—a level at which great care should be taken to prevent seismic disturbances.

WHERE

For tone contouring, the equalizer may be used at any point in the signal chain, such as insert loops in a mixer to equalize a single instrument, sweeten a tape recording, etc. When an equalizer is used for acoustical correction, the equalizer should be one of the *last* pieces of gear in front of the amplifiers and active crossovers. Any further up the line may cause electrical mismatch with other line level equipment. Here are a few *general* guidelines useful in deciding exactly where to install the MQ 302 in the system. See Figure 1.

DOWNSTREAM OF THE COMPRESSOR

Since system EQ is aimed at the *acoustical* problems, it should be installed *after* any compressor, which is designed to operate on electrical program material. For one thing, the equalizer slider settings will change with each new location, which in turn affects the control voltage and threshold responses of the compressor and renders it inconsistent. Secondly, healthy amounts of boost often strains the dynamic range of compressors and increases the danger of distortion and/or overload.

UPSTREAM OF THE LIMITER

If a limiter is installed strictly to protect the drivers, then install the limiter just before the power amplifiers. A good limiter leaves the dynamics unchanged until the amplifier reaches driver overload levels.

AFTER ANY SYSTEM GAIN

Here is a trap many fall into: mixer, compressor/limiter, equalizer, active crossover and power amplifier—all with gain controls, and all working *against* each other. The MQ 302 has good low noise levels, but it *is* a line-level active component. If you set the INPUT LEVEL control way down (to avoid overdriving the compressor which is wrongly connected *after* it), then you must turn *up* the compressor, crossover and amplifier controls to compensate; now you'll blame the equalizer for being too noisy. Whenever headroom allows, try to take all the gain at the mixer, and run unity levels from there on. This also gives better noise performance from the mixer. Connect the MQ 302 before the amplifier or active crossover. Take any required line gain before the MQ 302. Avoid taking a lot of gain in the crossover or power amps as this creates noise and hum problems. The MQ 302 operates at unity gain around “8” on the INPUT LEVEL control when sliders average to center (0 dB). You can test this with the EQ BYPASS switch—adjust the INPUT LEVEL control so that volume does not change when switching between ACTIVE and BYPASS.

SEND/RECEIVE LOOPS

Mixers, mixer/preamps and the like often provide send/receive loops for additional effects or EQ, and the MQ 302 works well in this situation. Just be sure to keep input trim or gain controls turned up as far as the mixer input headroom will allow, to avoid taking excessive gain downstream and creating noise problems. Remember to feed the MQ 302 with roughly line level program (between -10 dBV and +4 dBu to +20 dBu), and all should work fine.

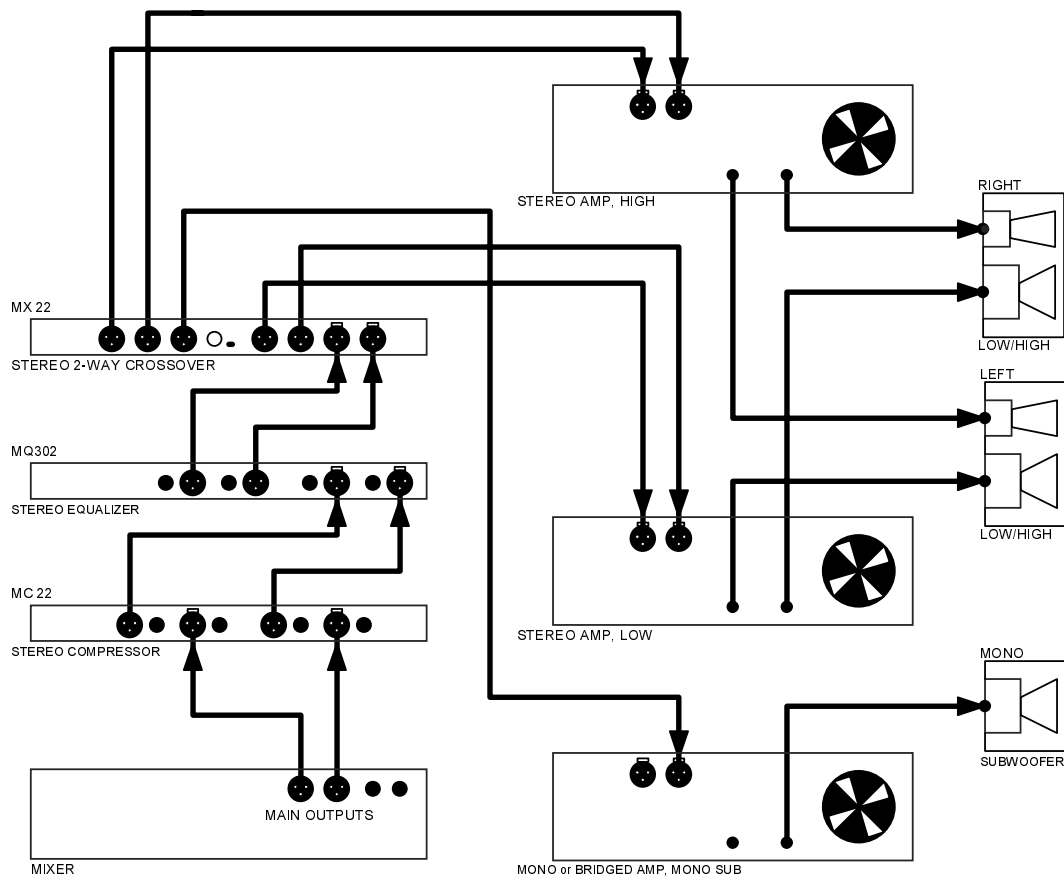

Figure 1. Stereo Biamp System with Equalizer

OPERATING INSTRUCTIONS

The MQ 302 is an accurate, professional quality instrument capable of precise equalization down to a fraction of a dB. You can expect several advantages from your constant-Q equalizer over conventional designs: Moving one slider will not affect neighboring filters as much, so you won't spend time re-adjusting sliders (we call this "equalizing the equalizer"). You'll be able to obtain better feedback control without losing sound quality. All sliders maintain smooth, consistent and accurate calibrated control over filter levels, which is especially critical in low-profile equalizer designs. Because of this, the overall EQ adjustment process is significantly easier and more effective.

Equalizing a sound system by ear is a *very* difficult process to achieve successfully, especially in a timely manner. Although the human ear is very sensitive, it is *not* calibrated, nor consistent, and frankly the odds *against* a well behaved, clear sound system are very great when tuned by ear. Most people know when a sound system doesn't sound good, unfortunately they just can't tell exactly *why* and *where* it's not right. ***Because of this, we strongly recommend the use of a realtime analyzer to properly equalize your system with the MQ 302.***

Forget everything you've thought about analyzers and consider this: there's a newer generation of analyzers which are compact, simple, very easy to operate and surprisingly affordable. Best of all, they can make a drastic improvement in the overall performance of your sound system while saving

you a great deal of time and effort.

A realtime analyzer helps you quickly achieve things nearly impossible by ear: flatten speaker response, minimize feedback, remove room resonance and allows accurate crossover alignment. In most cases, simply "normalizing" or "flattening" a sound system is a surprisingly drastic improvement, but *don't stop there*:

Remember this Rane proverb: "Look, don't stop, and listen." Once you have aligned the system by **looking** at the analyzer, **don't stop** at this point. **Listen** to the music program and make additional adjustments to suit your taste, the type of music and your audience. Fatten the bass, sweeten the highs, brighten the mids. Since you are starting from a "tuned" system, your ear will not be fooled into thinking bass is too high when actually mids are too low, or that highs are too weak when really the mids are too strong.

Fact: analyzers don't have good taste—people do. Analyzers consistently and accurately "tell it like it is," but ultimately, personal judgment determines what sounds good or appropriate. In fact, final optimum EQ settings, made *after* analyzer testing, will vary greatly depending on the type of music, sound pressure level, size of the venue and disposition of the audience.

Conclusion: *To consistently obtain the best sound from your system, use an analyzer and then your ears, in that order.* The analyzer supplies the consistency and calibration while your ear supplies the good taste.

MOJO GLOSSARY

balanced line The recommended method of interconnecting audio equipment. A balanced line requires three conductors: a twisted-pair for the signal (positive and negative) and an overall shield. *The shield must be tied to the chassis at both ends for hum-free interconnect.*

bandwidth *Abbr. BW* The numerical difference between the upper and lower -3 dB points of an audio band.

clipping What occurs when a unit tries to produce a signal *larger than its power supply*. The signal takes on a flat-topped, or *clipped* shape. When an amplifier tries to go above its max power, it *clips*.

compressor A signal processing device used to *reduce the dynamic range* of the signal passing through it. For instance, an input dynamic range of 110 dB might pass through a compressor and exit with a new dynamic range of 70 dB. The modern usage for compressors is to turn down (or reduce the dynamic range of) just the loudest signals. Other applications use compressors to control the *creation* of sound. When used in conjunction with microphones and musical instrument pick-ups, compressors help determine the final timbre by selectively compressing specific frequencies and waveforms.

connectors Audio equipment uses different styles:

RCA An *unbalanced* pin connector commonly used on consumer and some pro equipment; aka *phono plug*

XLR A 3-pin connector common on pro audio equipment.

Preferred for *balanced line* interconnect; aka *Cannon plug*

1/4" TRS 1. *Stereo* 1/4" connector consisting of *tip* (T), *ring* (R), and *sleeve* (S) sections, with T = *left*, R = *right*, and S =

ground/shield. 2. *Balanced* interconnect with the pos & neg signal lines tied to T and R respectively and S acting only as an overall shield. 3. *Insert loop* interconnect with T = *send*, R =

return, and S = *ground/shield*. [Think: *ring, right, return*]

1/4" TS *Mono* 1/4" connector consisting of *tip* (T) [signal] and

sleeve (S) [ground & shield] for *unbalanced* wiring.

constant-Q equalizer (also **constant-bandwidth**) The bandwidth remains constant for all boost/cut levels. Since Q and bandwidth are interrelated, the terms are fully interchangeable.

decibel *Abbr. dB* (named after *Alexander Graham Bell*). The preferred method and term for representing the *ratio* of different audio levels. Being a ratio, *decibels have no units*. Everything is relative. So it must be relative to some *0 dB reference point*. A suffix letter is added to distinguish between reference points:

0 dBu A reference point equal to 0.775 V

+4 dBu Standard pro reference level equal to 1.23 V

0 dBV A reference point equal to 1.0 V

-10 dBV Standard reference level for consumer and some pro audio use, equal to 0.316 V. *RCA* (phono) connectors are a good indicator of units operating at -10 dBV

dynamic range The ratio of the loudest signal to the quietest signal in a unit or system as expressed in *decibels* (dB).

expander A signal processing device used to *increase the dynamic range* of the signal passing through it. Expanders complement compressors. For example, a compressed input dynamic range of 70 dB might pass through an expander and exit with a new *expanded* dynamic range of 110 dB. Modern expanders usually operate only *below a set threshold point*, i.e., they operate only on low-level audio. The term *downward expander* describes this type of application.

ground Any electrical reference point for measuring voltage levels. Usually a large conducting body, such as the earth or an electric circuit connected to the earth. Chassis should always be at earth potential.

headroom The level in dB between the typical operating level and *clipping*. For example, a nominal +4 dBu system that clips at +20 dBu has 16 dB of *headroom*.

hum Unwanted sound contaminating audio paths due to EMI (electro-magnetic interference) caused by AC power-lines & transformers getting into unbalanced, poorly shielded, or improperly grounded connecting cables. Hum has a definite smooth (sine wave) repetitive sound based on the harmonics of 50/60 Hz such as 100/120 Hz and 150/180 Hz.

interpolating Term meaning to insert between two points. If a graphic equalizer's adjacent bands, when moved together, produce a smooth response without a dip in the center, they are *interpolating* between the fixed center frequencies.

levels Terms used to describe relative audio signal levels:

mic-level Nominal signal coming directly from a microphone.

Very low, in the microvolts, and requires a preamp with at least 60 dB gain before using with any *line-level* equipment.

line-level Standard +4 dBu or -10 dBV audio levels.

instrument-level Nominal signal from musical instruments using electrical pick-ups. Varies widely, from very low *mic-levels* to quite large *line-levels*.

limiter A compressor with a fixed *ratio* of 10:1 or greater. The dynamic action prevents the audio signal from becoming larger than the *threshold* setting.

Linkwitz-Riley crossover The most preferred active crossover design. It features steep 24 dB/octave slopes, in-phase outputs, and flat amplitude response. Due to the in-phase outputs the acoustic lobe resulting when both loudspeakers reproduce the crossover frequency is always on-axis (not tilted up or down) and has no peaking.

noise 1. *Interconnect*. Unwanted sounds contaminating audio paths. RFI (radio frequency interference) caused by broadcast signals leaking into unbalanced, poorly shielded, or improperly grounded connecting cables. Also by light dimmers, motor controls and computers. 2. *Music*. A random mix of audio frequencies not harmonically related, sounding like radio static.

polarity A signal's electromechanical potential with respect to a reference. For example, a microphone has *positive polarity* if a positive pressure on its diaphragm results in a positive output voltage. **polarity vs. phase shift:** *polarity* refers to a signal's *reference* NOT to its *phase shift*. Being 180 degrees *out-of-phase* and having *inverse polarity* are DIFFERENT things. We wrongly say something is *out-of-phase* when we mean it is *inverted*. One occurs over a period of *time*; the other occurs instantaneously.

Q (upper-case) Quality factor. Defined to be the ratio of the center frequency *f* divided by the bandwidth *BW* for a bandpass filter.

signal-to-noise ratio The ratio in dB between a reference level and the noise floor. For example, a signal-to-noise ratio of 90 dB re +4 dBu, means the noise floor is 90 dB below a +4 dBu ref.

unbalanced line An audio interconnect scheme using one wire with an overall shield. The shield must perform two functions: act as the return signal path (*ground*) and to protect the conductor from noise (*shield*). Consequently this method is vulnerable to hum & noise problems.

unity gain A gain setting of one. The level out equals the level in.

WARNING: SHOCK HAZARD

Never use an AC line cord ground-lift adapter or cut off the 3rd pin. It is illegal and dangerous.

MQ 302 SPECIFICATIONS

Parameter	Specification	Limit	Units	Conditions/Comments
Equalizer:				
.....Channels	Two			
.....Bands	(2x30) 1/3-Octave ISO Spacing			From 25 Hz to 20 kHz
.....Type	Constant-Q			Smooth combining
.....Accuracy	3		%	Center frequency
.....Travel	20		mm	Positive grounded center detent
.....Range	±12	1	dB	
Inputs:				
.....Type	Active Balanced			
.....Connectors	XLR & ¼" TRS			Pin 2 "hot" per AES standards
.....Impedance	20k	1%	ohms	
.....Maximum Level	21	1	dBu	
Outputs:				
.....XLR	Active Balanced			100 ohms impedance each leg
.....¼"	Active Unbalanced			100 ohms impedance
.....Maximum Level	+20	1	dBu	2k ohms balanced & unbalanced
Overall Gain Range	Off to +6	-0/+4	dB	Sliders centered
RFI Filters	Yes			
Frequency Response	20-20 kHz	+0,-2	dB	
THD+Noise	0.009	.002	%	+4 dBu, 20-20 kHz
IM Distortion (SMPTE)	0.005	.003	%	60 Hz/7 kHz, 4:1, +4 dBu
Signal-to-Noise Ratio				20 kHz noise BW; balanced out re +4 dBu
	96	2	dB	Sliders centered, re +4 dBu, 20 kHz BW
	76	2	dB	Sliders all boosted, re +4 dBu, 20 kHz BW
	91	2	dB	Sliders all cut, re +4 dBu, 20 kHz BW
Channel Separation	80	3	dB	1 kHz
Common Mode Rejection	40	1	dB	1 kHz
Maximum Power	12		W	
Unit: Agency Listing				
.....120 VAC model	UL cUL (Canada)			UL 6500 (file E104174) C22.2 (file E104174)
.....230 VAC model	CE (EMC) EN55013, EN55020 CE (Safety) EN60065			EMC Directive 89/336/EEC LV Directive 73/23/EEC
.....Construction	All Steel			
.....Size	1.75"H x 19"W x 8.5"D (1U)			(4.4 cm x 48.3 cm x 21.6 cm)
.....Weight	5 lb			(2.3 kg)
Shipping:				
.....Size	4.25" x 20.3" x 13.75"			(11 cm x 52 cm x 35 cm)
.....Weight	9 lb			(4.1 kg)
Note: 0 dBu = 0.775 Vrms				

SOUND SYSTEM INTERCONNECTION

Rane's policy is to accommodate rather than dictate. However, this document contains suggestions for external wiring changes that should ideally only be implemented by trained technical personnel. Safety regulations require that all original grounding means provided from the factory be left intact for safe operation. No guarantee of responsibility for incidental or consequential damages can be provided. *(In other words, don't modify cables, or try your own version of grounding unless you really understand exactly what type of output and input you have to connect.)*

THE ABSOLUTE BEST RIGHT WAY TO DO IT

Use balanced lines and *tie the cable shield to the metal chassis (right where it enters the chassis) at both ends of the cable.*

A balanced line requires three separate conductors, two of which are signal (+ and -) and one shield. The shield serves to guard the sensitive audio lines from interference. Only by using balanced line interconnects can you *guarantee* (yes, *guarantee*) hum-free results. Always use twisted pair cable. Chassis tying the shield at each end also *guarantees* the best possible protection from RFI [radio frequency interference] and other noises [neon signs, lighting dimmers].

THE NEXT BEST RIGHT WAY TO DO IT

The quickest, quietest and most foolproof method to connect balanced and unbalanced is to **transformer isolate all unbalanced connections**. Your audio dealer can recommend such a transformer.

The goal of transformer adaptors is to allow the use of *standard cables*. With these transformer isolation boxes, modification of cable assemblies is unnecessary. Virtually any two pieces of audio equipment can be successfully interfaced without risk of unwanted hum and noise.

Another way to create the necessary isolation is to use a *direct box*. Originally named for its use to convert the high impedance, high level output of an electric guitar to the low impedance, low level input of a recording console, it allowed the player to plug "directly" into the console. Now this term is commonly used to describe any box used to convert unbalanced lines to balanced lines.

THE LAST BEST RIGHT WAY TO DO IT

If transformer isolation is not an option, special cable assemblies are a last resort. The key here is to prevent the shield currents from flowing into a unit whose grounding scheme creates ground loops (hum) in the audio path (i.e., most audio equipment). Do not be tempted to use 3-prong to 2-prong "cheater" adapters to lift grounds. This is a dangerous and illegal practice.

It is true that connecting both ends of the shield is theoretically the best way to interconnect equipment – though this assumes the interconnected equipment is internally grounded properly. Since most equipment is *not* internally grounded properly, connecting both ends of the shield is not often practiced, since doing so can create noisy interconnections.

A common solution to these noisy hum and buzz problems involves disconnecting one end of the shield, even though one can not buy off-the-shelf cables with the shield disconnected at one end. The best end to disconnect is a matter of personal preference and should be religiously obeyed; choose inputs or outputs and always lift the side you choose (our drawings happen to disconnect the outputs). If one end of the shield is disconnected, the noisy hum current stops flowing and away goes the hum — but only at low frequencies. A one-end-only shield connection increases the possibility of high frequency (radio) interference since the shield may act as an antenna. Many reduce this potential RF interference by providing an RF path through a small capacitor (0.1 or 0.01 microfarad ceramic disc) connected from the lifted end of the shield to the chassis. The fact that many modern day installers still follow this one-end-only rule with consistent success indicates this and other acceptable solutions to RF issues exist, though the increasing use of digital and wireless technology greatly increases the possibility of future RF problems.

See the following page for suggested cable assemblies for your particular interconnection needs. Find the appropriate output configuration from either your mixer output or the MQ 302 output (down the left side), and then match this with the correct balanced or unbalanced input to the MQ 302 or the amplifier (down the right side.) An "off-the-shelf" cable may be available or modifiable. Soldering should only be attempted by those trained in the art.

SUMMARY

If you are unable to do things correctly (i.e. use fully balanced wiring with shields tied to the *chassis* at the point of entry, or transformer isolate all unbalanced signals from balanced signals) then there is no guarantee that a hum free interconnect can be achieved, nor is there a definite scheme that will assure noise free operation in all configurations.

WINNING THE WIRING WARS

- Use balanced connections whenever possible.
- Transformer isolate all unbalanced connections from balanced connections.
- Use special cable assemblies when unbalanced lines cannot be transformer isolated.
- Any unbalanced cable must be kept under ten feet (three meters) in length. Lengths longer than this will amplify the nasty side effects of unbalanced circuitry's ground loops.

This information was condensed from Rane Note 110, "Sound System Interconnection". If you would like the complete note, call or email the factory, download it from Rane's web site (addresses on page Manual-10) , or ask your dealer for a copy.

VARIOUS XLR & 1/4" CABLE ASSEMBLIES

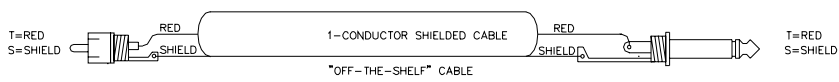
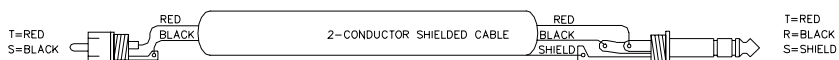
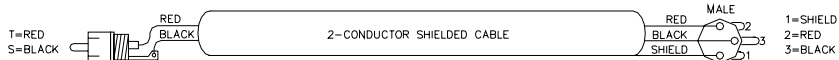
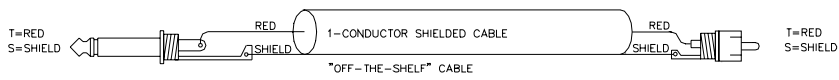
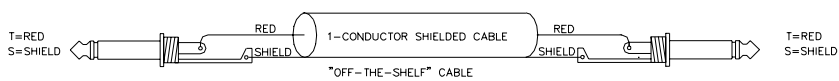
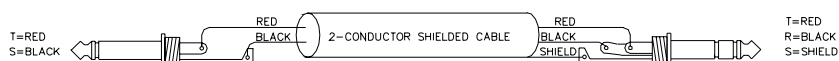
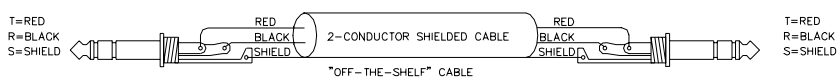
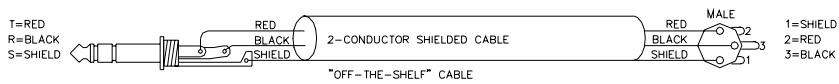
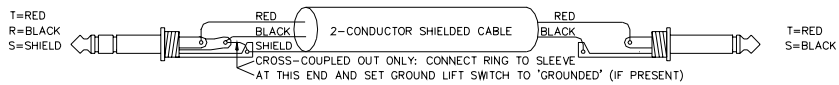
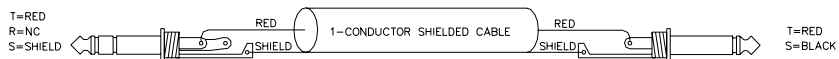
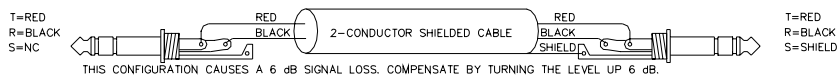
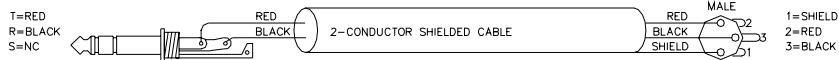
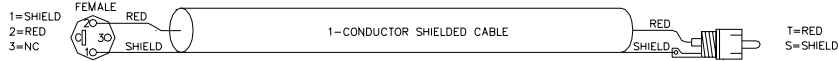
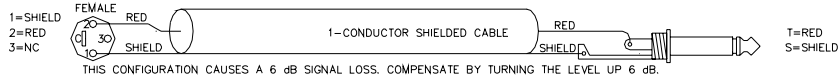
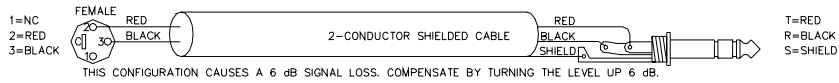
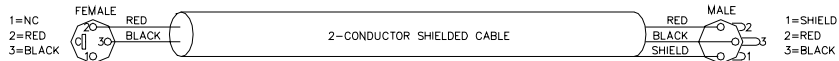

FROM OUTPUT

TO INPUT

MQ 302 BLOCK DIAGRAM

