

# Mojo Filters

## MQ 302S

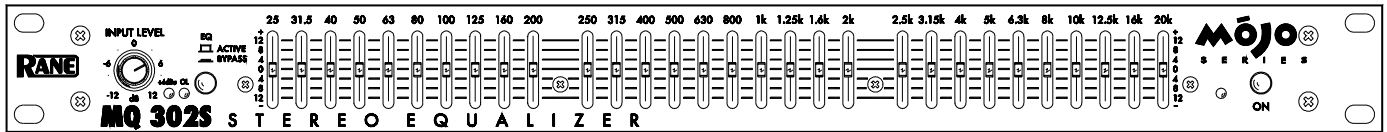

## MQ 302L

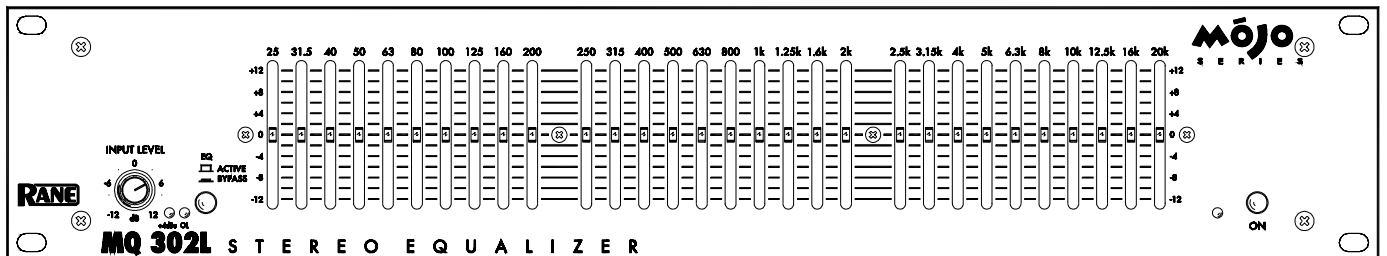

### General Description

Here's the long and the short of it. The MQ 302S uses Short space-saving 20 mm sliders, while the MQ 302L uses Long and more precise 45mm sliders. All other features are identical.

The MQ 302S and MQ 302L are 30-band equalizers with ultimate stereo accuracy. The single set of faders controls both left and right channels simultaneously, maintaining true stereo tracking and utilizing constant-Q technology. These EQs fills the void for true stereo applications.

Both models are accurate, professional quality instruments capable of precise equalization down to a fraction of a dB. You can expect several advantages from your constant-Q equalizer over conventional designs: moving one slider will not affect neighboring filters as much, so you won't spend time re-adjusting sliders (we call this "equalizing the equalizer"). You'll be able to obtain better feedback control

without losing sound quality. All sliders maintain smooth, consistent and accurate calibrated control over filter levels, which is especially critical in low-profile equalizer designs. Because of this, the overall EQ adjustment process is significantly easier and more effective.

An Input Level control is provided along with a Bypass switch, enabling easy gain comparisons between equalized and unequalized signal. +4 dBu and Overload indicators detect both input and post-EQ levels.

Either unit interfaces easily to many types of systems, featuring balanced XLR Inputs and Outputs, along with balanced 1/4" TRS Inputs and unbalanced 1/4" TS Outputs.

The Rane Mojo Series maintains sonic and construction quality not found (until now) in this price range. Designed for the working musician...simple operation...reduced features...without compromise in audio quality or dependability.

### Features

- 30 Bands of Constant-Q Filters on Ganged Stereo Sliders
- Extremely Low Noise: 115 dB Dynamic Range
- Signal (+4 dBu) and Overload Indicators
- ±12 dB Level Control for Optimum Gain Structure
- Low Noise Toroid Transformer
- Balanced XLR & 1/4" Connectors
- Internal AC Power Supply Meets European CE Requirements

### MQ 302S

- 20 mm Filter Sliders Control Both Left & Right Channels
- Now with Signal (+4 dBu) and Overload Indicators
- New ±12 dB Level Control for Optimum Gain Structure

### MQ 302L

- 45 mm Filter Sliders Control Both Left & Right Channels



**MQ 302S & 302L**  
STEREO GRAPHIC EQUALIZERS



**Features and Specifications**

Parameter	Specification	Limit	Units	Conditions/Comments
Equalizer:				
.....Channels	Two			
.....Bands	(2x30) 1/3-Octave ISO Spacing			From 25 Hz to 20 kHz
.....Type	Constant-Q			Smooth combining
.....Accuracy	3		%	Center frequency
.....Travel, MQ 302S	20		mm	Positive grounded center detent
.....Travel, MQ 302L	45		mm	Positive grounded center detent
.....Range	±12	1	dB	
Inputs:				
.....Type	Active Balanced			
.....Connectors	XLR & ¼" TRS			Pin 2 "hot" per AES standards
.....Impedance	20k	1%	ohms	
.....Maximum Level	21	1	dBu	
Outputs:				
.....XLR	Active Balanced			100 ohms impedance each leg
.....¼"	Active Unbalanced			100 ohms impedance
.....Maximum Level	+20	1	dBu	2k ohms balanced & unbalanced
Overall Gain Range	-12 to +12	±1.5	dB	Sliders centered
RFI Filters	Yes			
Frequency Response	20-20 kHz	+0,-2	dB	
THD+Noise	0.009	0.002	%	+4 dBu, 20-20 kHz
IM Distortion (SMPTE)	0.005	0.003	%	60 Hz/7 kHz, 4:1, +4 dBu
Signal-to-Noise Ratio				20 kHz noise BW; balanced out re +4 dBu
	96	2	dB	Sliders centered, re +4 dBu, 20 kHz BW
	76	2	dB	Sliders all boosted, re +4 dBu, 20 kHz BW
	91	2	dB	Sliders all cut, re +4 dBu, 20 kHz BW
Channel Separation	80	3	dB	1 kHz
Common Mode Rejection	40	1	dB	1 kHz
Maximum Power	12		W	
Unit: Agency Listing				
.....120 VAC model	UL cUL (Canada)			UL 6500 (file E104174) C22.2 (file E104174)
.....230 VAC model	CE-EMC EN55103, EN55020 CE-Safety EN60065			EMC Directive 89/336/EEC LV Directive 73/23/EEC
.....Construction	All Steel			
MQ 302S: Size	1.75"H x 19"W x 8.5"D (1U)			(4.4 cm x 48.3 cm x 21.6 cm)
.....Unit Weight	5 lb			(2.3 kg)
.....Shipping Size	4.25" x 20.3" x 13.75"			(11 cm x 52 cm x 35 cm)
.....Shipping Weight	9 lb			(4.1 kg)
MQ 302L: Size	3.5"H x 19"W x 8.5"D (2U)			(8.9 cm x 48.3 cm x 21.6 cm)
.....Unit Weight	7 lb			(3.2 kg)
.....Shipping Size	4.25" x 20.3" x 13.75"			(11 cm x 52 cm x 35 cm)
.....Shipping Weight	11 lb			(5.0 kg)
Note: 0 dBu = 0.775 Vrms				

### MQ 302S and MQ 302L Block Diagram

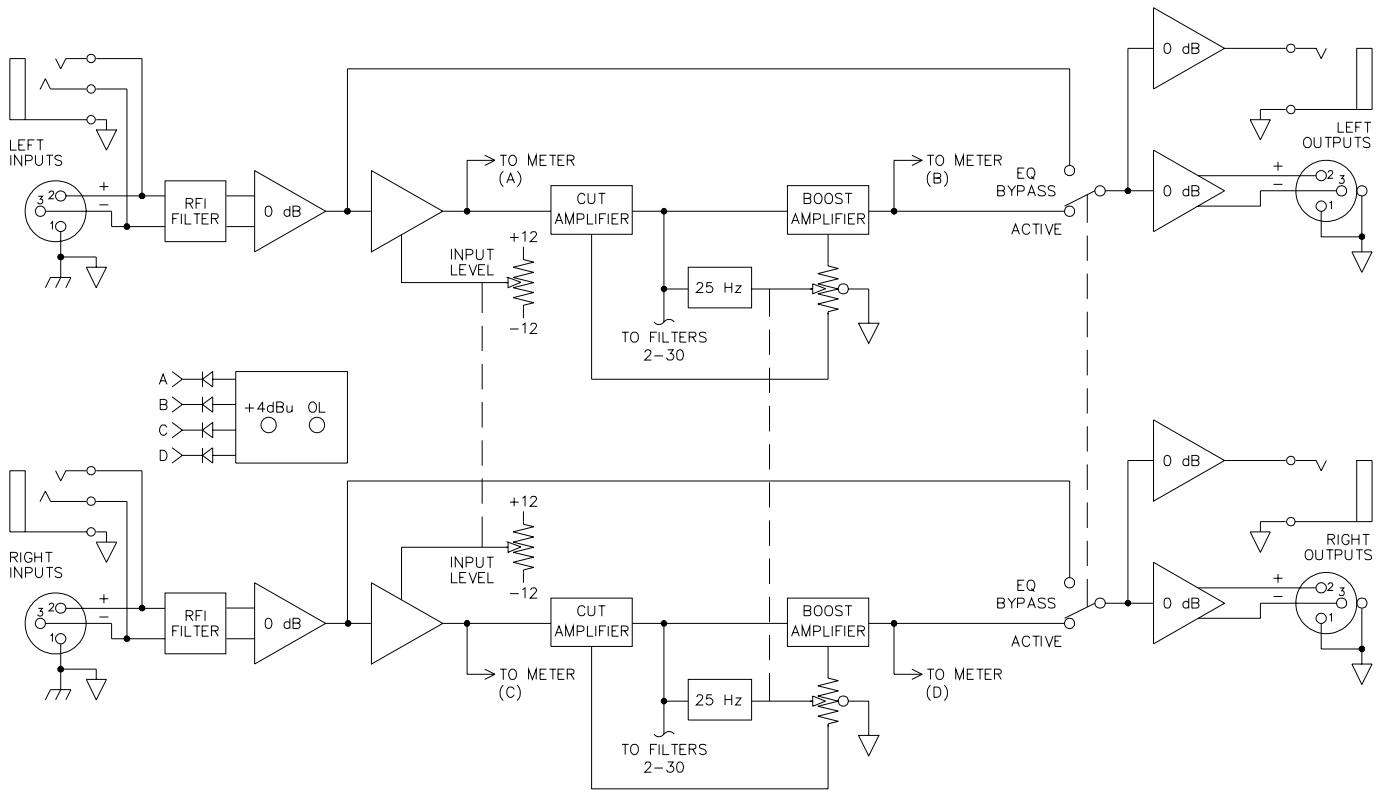

### Application Information

Constant-Q graphic equalizers arose from the sound professional's need for greater control with less interaction than previously possible with conventional equalizers. Truth in slider position became a requirement. The curve traced out by the slider positions on constant-Q designs indeed represents the actual changes to the frequency response. On conventional designs they do not.

You use a constant-Q graphic the same way you use a conventional graphic. You just get the desired results quicker, with far less after adjustment to the adjacent sliders. Eliminating a phenomena Rane calls "equalizing the equalizer".

The accompanying figures dramatically show the advantages of constant-Q designs. For more in-depth information please see RaneNote 101, "Constant-Q Graphic Equalizers."

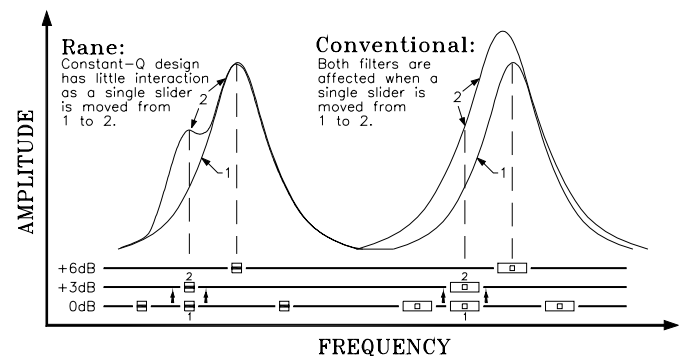
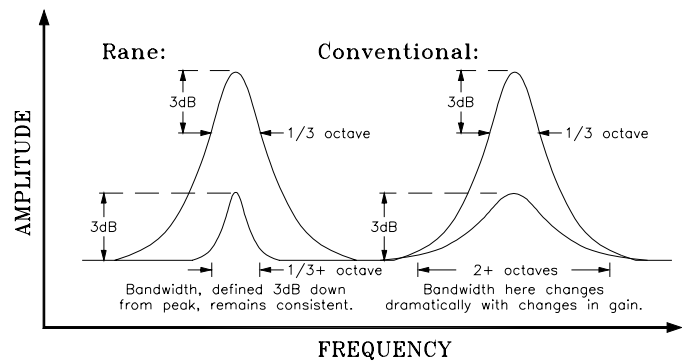



# MQ 302S & 302L

## STEREO GRAPHIC EQUALIZERS



### MQ 302S Rear Panel

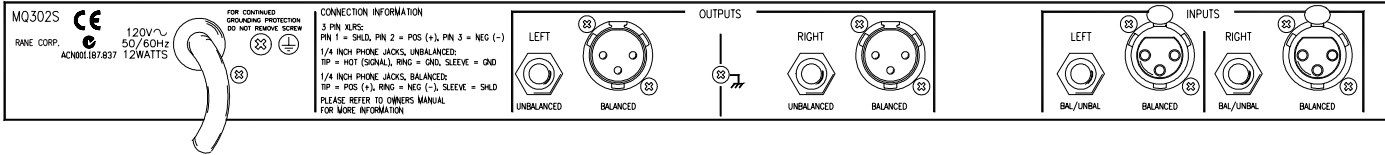

### MQ 302L Rear Panel

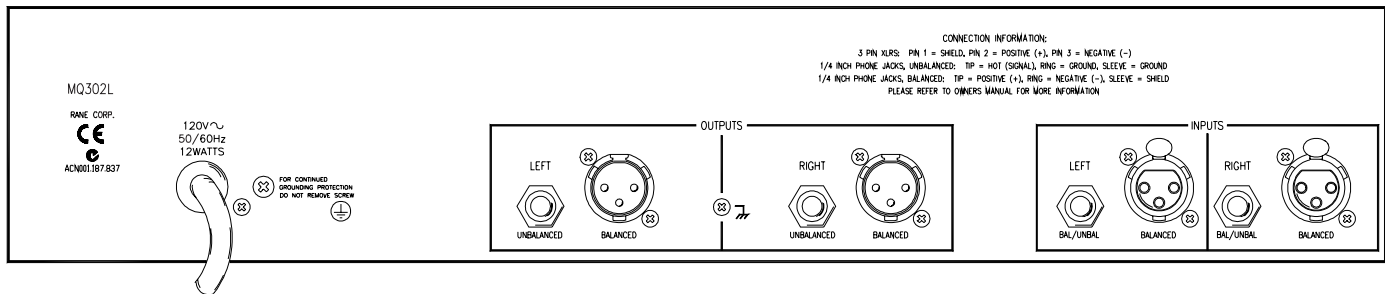

## Architectural Specifications

The graphic equalizer shall be of constant-Q design to minimize interactions between adjacent bands, and contain frequency bands located on standard ISO center frequencies. Each band shall have a bandwidth of 1/3-octave with a boost/cut range of 12 dB. A detented and positively grounded 0 dB point shall be provided on 20 mm (MQ 302S) or 45 mm (MQ 302L) linear sliders with dust dams. A single set of sliders shall control both channels. A rotary overall level control shall be provided with a range from 12 dB of attenuation to 12 dB of gain. The level control shall provide a detented 0 dB center point.

The unit shall include +4 dBu and overload indicators detecting both input and post-equalizer levels.

The inputs shall be active balanced/unbalanced designs terminated with both XLR and 1/4" TRS (tip-ring-sleeve) connectors. The outputs shall have active balanced XLR and unbalanced 1/4" TS (tip-sleeve) connectors. RFI filters shall be provided. The unit shall provide a bypass switch.

The unit shall be capable of operation by means of its own built-in power supply connected to 120 VAC (230 VAC where applicable) and meet CE requirements. The chassis shall be entirely constructed from cold-rolled steel.

*The unit shall be a Rane Corporation MQ 302S or MQ 302L Stereo Graphic Equalizer.*