

General Description

Rane proudly presents the MP 44 Mixer. Finally, a mixer that supports DJ creativity while club sound quality and equipment remain in tact! The MP 44's unique set of features combine with superior audio performance to provide unparalleled value.

The MP 44 features four Input Buses, each providing:

- Assignment to the A-side, B-side or Post-Crossfader
- Phono/CD and Line inputs
- Gain trim (± 12 dB)
- Overload indicator
- *FlexFX*TM loop assignment
- 3-band full-cut *Accelerated-Slope*TM Tone Controls.

Two Auxiliary Inputs are provided. Aux Input A is unbalanced, while Aux Input B is balanced. Each Input features off to +6 dB Level controls.

Two Auxiliary Outputs are provided. Aux Output A is unbalanced. Aux Output B is balanced. Each Output features off to +6 dB Level controls. Each Output may be assigned Pre-Master Effects loop, Post-Master Effects loop or Post Master Effects loop plus Mic. These features provide the flexibility to use the Aux Outputs for recording or additional zones.

High performance VCA level controls are used for House and Booth level, providing very low travel noise and long life. A Master left/right balance control and recessed Master Mono switch with LED indicator are provided.

A high-performance Master Limiter with true RMS detectors limits both House and Booth maximum levels. The

Special Club Owner features include:

- High-performance Master Limiter (limits House & Booth Outs)
- Exceptional overload characteristics
- Automatic Emergency Page Input
- Optional remote DC Master Level control

Special DJ features include:

- 3-band full-cut Tone controls (off to +6 dB) on each of the 4 Input buses
- *FlexFX*TM assignment allows processing any combination of the 4 Input buses by the Effects loop, regardless of A-side, B-side or Post-Crossfader assignment!
- A-side, B-side or Post-Crossfader assign for each Input bus
- High performance VCA Crossfader with Contour control
- High performance VCA channel faders
- 2 Auxiliary Inputs; 2 Mic Inputs
- 2 Auxiliary Outputs; House, Booth and Light Outputs
- 2 automatic Crossfader CD Triggers
- 2 Mic Preamps with independent EQ & Effects Loops
- Versatile split cue headphone monitoring and metering

Parameter	Specification
Phono Inputs	RCA
.....Impedance	47k ohms 1%, 200 pF 5%
.....Gain @ 1 kHz	35 dB
.....Frequency Response	RIAA ±.5 dB 30-20 kHz
Unbalanced Line Inputs	RCA
.....Maximum Input	+20 dBu
.....Input Impedance	10k ohms, 1%
Input Bus	
.....Gain Trim Range	±12 dB
.....Frequency Response	15 Hz to 30 kHz, -3dB point
.....Channel Separation	80 dB, min., 1 kHz
.....Left/Right Separation	70 dB, min., 1 kHz
.....Channel Fader Feed-through	-90 dB, max., 1 kHz
.....Crossfader Contour	Continuous range from blend to cut
.....Input Overload Indicator	3 dB before clip
FlexFX Loop	unbalanced, ¼" tip/sleeve
.....Input / Output Impedances	10k ohms 1% / 300 ohms 1%
.....Max Input / Output Level	+16 dBu
Low end cut filter	12 dB/octave, Butterworth
.....Corner Frequency	15 Hz, ±5%
Aux A Input / Output	Unbalanced, RCA
.....Input / Output Impedances	10k ohms 1% / 300 ohms 1%
.....Input / Output Gain	off to +6 dB
.....Max Input / Output Level	+20 dBu
Aux. B Input / Output	Balanced, ¼" TRS
.....Input / Output Impedances	10k ohms min. / 100 ohms 1% each leg to gnd
.....Input / Output Gain	off to +6 dB
.....Max Input / Output Level	+20 dBu
Master Effects	unbalanced, ¼" tip/sleeve
.....Input / Output Impedances	10k ohms 1% / 300 ohms 1%
.....Max Input / Output Level	+20 dBu
Light Trigger	balanced, ¼" TRS
.....Gain Range	off to +6 dB
.....Output Impedance	100 ohms 1% each leg to gnd
.....Maximum Output	+20 dBu
Limiter	True RMS feed-forward
.....Threshold Range	-20 to +20 dBu
.....Ratio	infinity:1
Remote Level Input	Wired DC, 3-pin Euroblock
.....Control Voltage Range / Law	0 to +5 volts, 125mV/dB
.....Gain Range	0 to -40 dB
.....Input Impedance	100k ohms 1%
House Page Input	balanced, 3-pin Euroblock
.....Input Z	10k ohms 1%
.....Max. Input	+20 dBu
.....Gain Range	-20 to +6 dB
.....Auto Detect Threshold	-20 dBu (after gain)
.....Program Attenuation	40 dB

Note: 0 dBu=0.775 Vrms
All specifications are typical unless otherwise indicated.

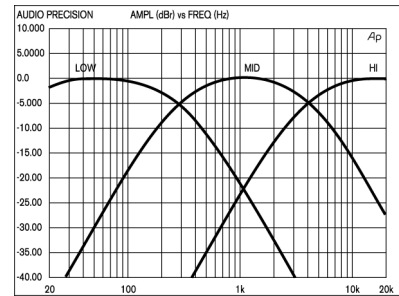

This chart shows the response of each Low, Mid and Hi tone control when the other two are set to OFF (full cut).

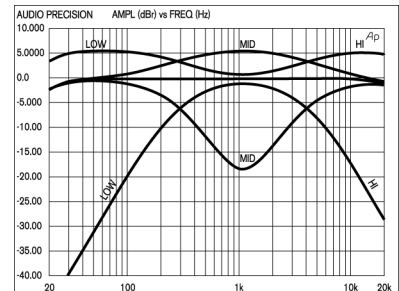

This chart shows the combined response of the three tone controls.

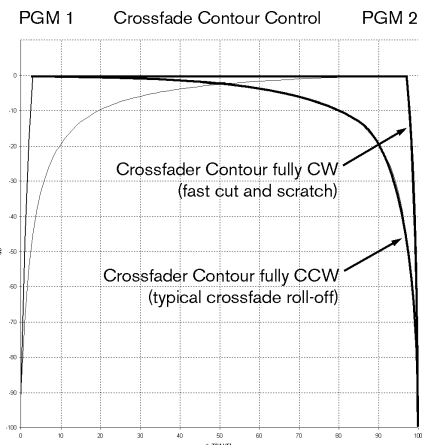

rear panel threshold control range is ± 20 dBu. Threshold indicators are provided on both the front and rear panels.

The optional Rane VR 1 Remote Level control may be used to externally control the House Output. A remote DC Level Control port allows 40 dB of Master Mix gain control. Any linear potentiometer from 10k to 100k ohms works with the internal reference. An external ground referenced control voltage (0 to 5 VDC) may also be used. The gain control law is 125 mV/dB.

Applied signal on the Emergency Page Input automatically mutes all program material at House and Booth Outputs. The Emergency Page level is set independently using a recessed rear panel control.

Two CD Trigger Outputs are provided via 3.5mm (1/8") mini TRS jacks. Outputs are normally high with 50 ms active low trigger pulses. Start is on tip and stop is on sleeve. Ring has no connection. The CD Trigger Enable switch is located on the front panel.

Parameter	Specification
Main Mic	Active balanced, combo XLR / 1/4" TRS
.....Gain Range	15 to 60 dB, typical
.....Maximum Input	+4 dBu
.....EIN	-128 dBu, Rs=150 ohms, g=60, 20 - 20 kHz
.....Tone Type	3-band Baxandall
.....Phantom Power	12 volts
Aux Mic	Active balanced, combo XLR / 1/4" TRS
.....Mic Gain Range	30 to 60 dB
.....Line Gain Range	0 to 30 dB
.....EIN	-116 dBu, Rs 150 ohms, g=60 dB, 20-20 kHz
.....Tone Type	3-band Baxandall
House / Booth Output	Active balanced, XLR / 1/4" TRS
.....Output Z	100 ohms 1% each leg
.....Max Output	+20 dBu
.....S/N	>90 dB re +4 dBu, 20 Hz- 20 kHz, unity gain
.....THD+N	.1% 20-20 kHz, +4 dBu, unity, Rl=2k ohms
Meter	Peak dBu, 1 second peak hold
.....Sensitivity	+4 dBu / -10 dBV for 0 dB indication
Headphone Output Power	200 mW into 150 ohms
International Power Supply	85 to 250 VAC, 50/60 Hz, IEC receptacle
Unit: Agency Listing	UL / cUL Listed, E193164
.....Construction	All Steel
.....Size	8.75"H x 19"W x 5.3"D (5U)
.....Weight	17 lb (7.7 kg)
Shipping: Size	13.6"H x 20"W x 9"D (34.5 x 50.8 x 23 cm)
.....Weight	17 lb (7.7 kg)

Two Mic Inputs each provide

- Combination XLR / TRS input jacks
- Full range fader control
- 3-band tone controls
- Effects insert with Engage switch
- 12 dB auto Booth Ducking
- Blue Mic-Engage indicator

Main Mic features

- Studio-grade integrated microphone preamplifier
- Gain range 15 dB to 60 dB
- Selectable 12 volt phantom power

Aux Mic features

- Balanced input
- Mic or Line-level input
- Mic Gain Range 30 to 60 dB
- Line Gain Range 0 to 30 dB

Versatile headphone monitor allows Panning between Cue and House signals. Engage the Monitor Mono switch to Pan between Mono Cue and Mono Master (pre-house fader). The MP 44 uses a high-current, low-noise headphone amplifier, of course.

Versatile metering

- Stereo House output
- Mono-Cue / Mono-Master
- +4 dBu or -10 dBV sensitivity (switchable)

Light Trigger Output

- Balanced output (no transformer)
- Rear panel Level control

The MP 44 uses an internal universal switching power supply. The MP 44 is UL and cUL listed and CE certified with CE emissions and immunity certification.

Output Block Diagram

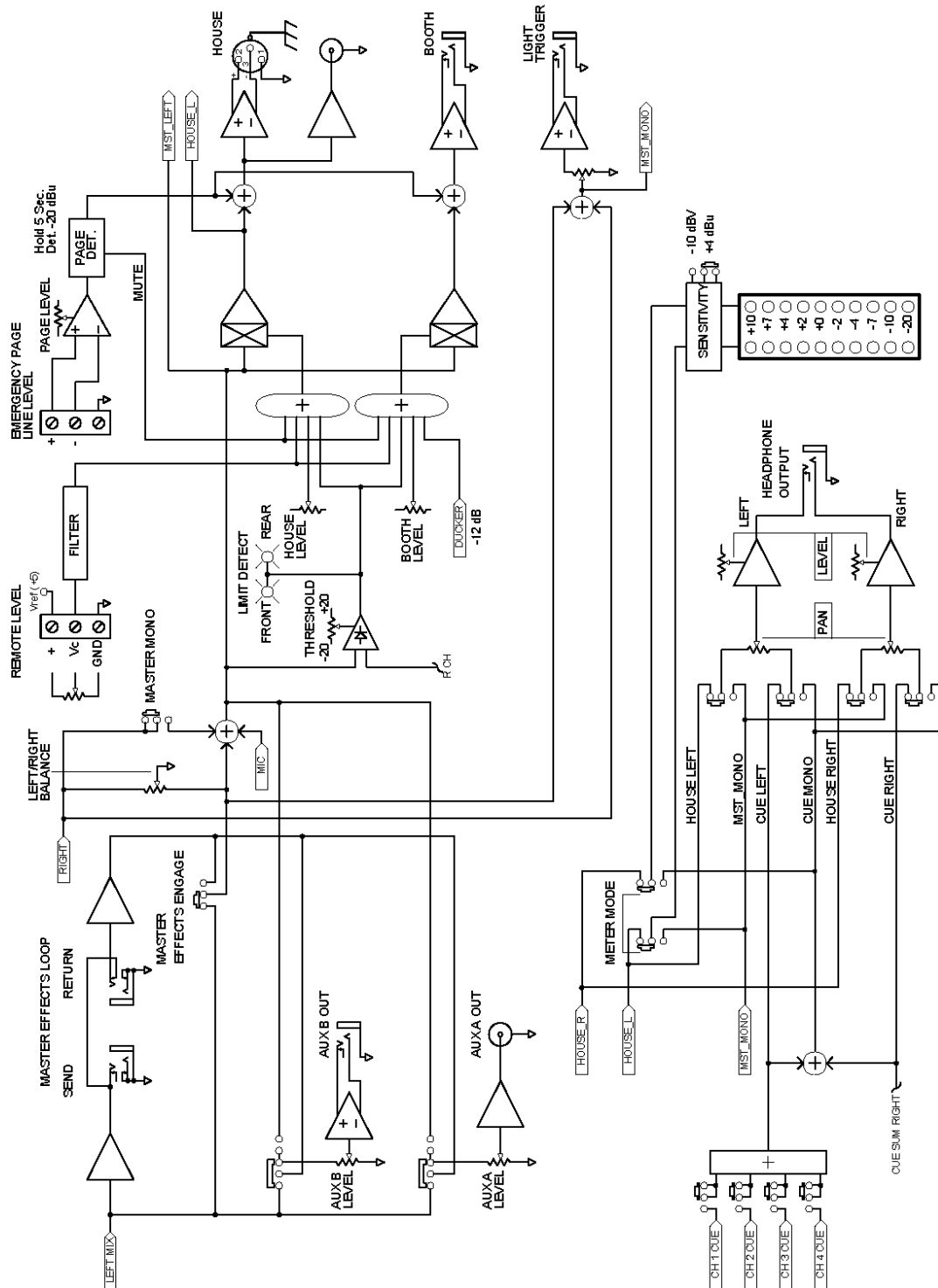

Rear Panel

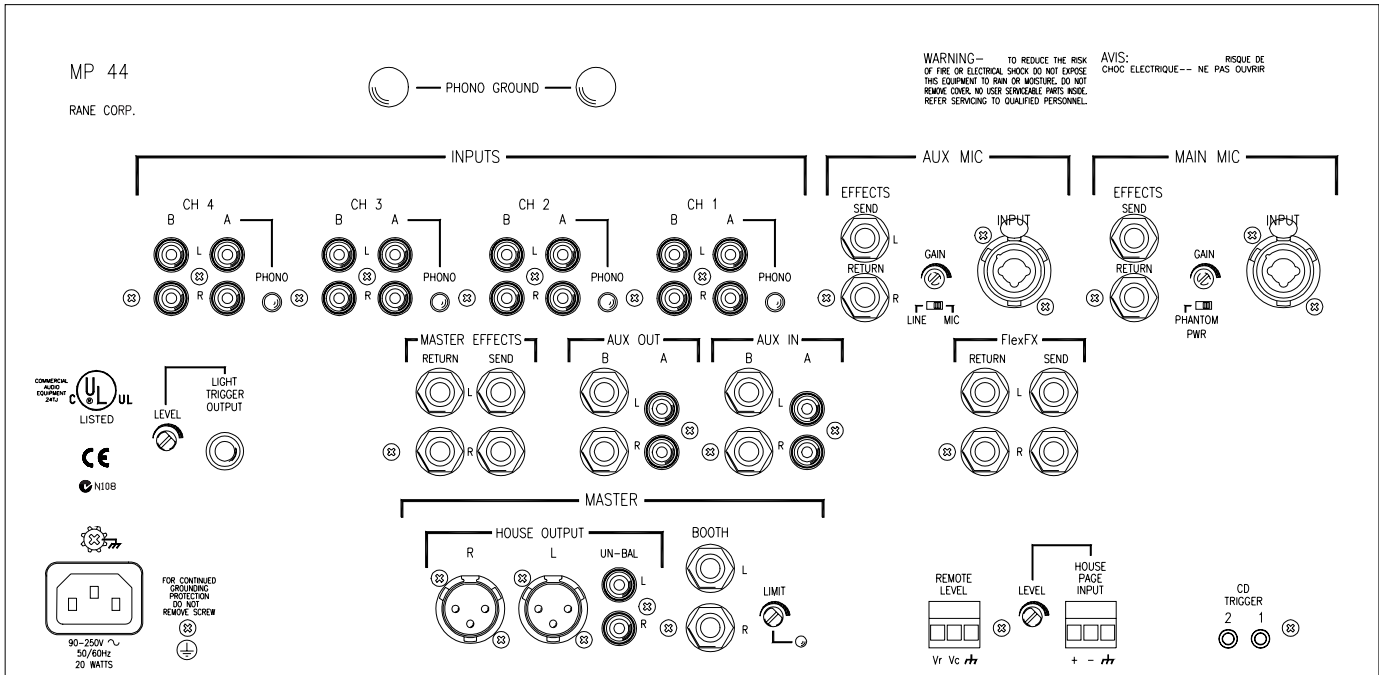

VR 1 Remote Level Control

The optional VR 1 allows the Master Output of the MP 44 to be controlled from a remote location. It mounts in any standard U.S. electrical box, which can then be fitted with a Decora™ cover of your choice. VR 1 part # 11791.

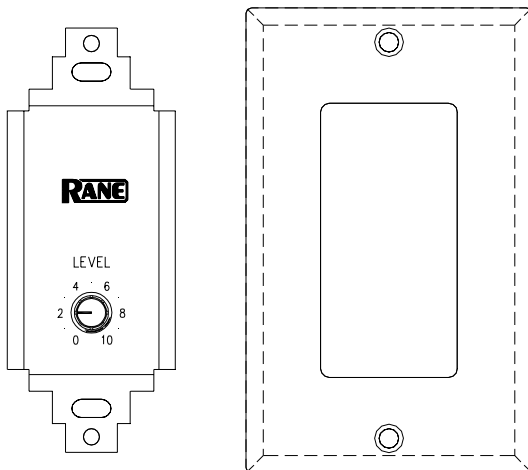

Decora is a registered trademark of Leviton