

## General Description

Following the success of the MP 24 DJ mixer, Rane presented the MP 22 for smaller systems and budgets. Rane then released the improved MP 22x design which featured an *Active Crossfader™* and balanced outputs. The MP 22z offers a new level of performance and flexibility with the addition of a full-range Crossfader Contour control (see Figure 1, back page).

The MP 22z features six stereo Inputs with individual Trims. Each of the two assignable mixing buses contains its own defeatable four band EQ, allowing separate equalization for different sources. All of the fader controls feature protective dust dams.

The Crossfader Contour control allows adjusting the “shape” of the Crossfader response from a gentle curve for smooth, long running fades, to the steep pitch required for top performance cut and scratch effects. *Active Crossfader* technology combines state of the art voltage controlled amplifier design with a professional quality crossfader control. This combination sets new standards for performance, reliability and serviceability. Virtually all crossfader noise is eliminated. Channel to channel cross-talk is greatly reduced and the *off* isolation of the faded channel is greatly increased. *Active Crossfader* technology dramatically

increases the service life of the crossfader. In the unlikely event of crossfader failure, there is no loss of signal. If a crossfader becomes rough or noisy, it may be “hot-swapped” during a performance *with no interruption of the audio signal*. Simply use the input faders to set the audio levels while the crossfader is out of service. The crossfader may be replaced with either a 60 mm version or a 45 mm version, your choice.

Each of the two Phono (RIAA) Inputs can switch to CD (Line Level) use via rear panel switches. Both Mic Inputs have Bass and Treble controls as well as an Effects Loop. The MP 22z also features a second Remote Mic/Line Input and a stereo Aux Line Input. Master Outputs include a stereo Master Loop for equalization or processing, as well as two separate Zone Outputs. The Tape Output and Zone 1 can be individually switched to include the Main Mic signal with the program signal. The MP 22z doesn't scrimp on its powerful Headphone Cueing system. The metering can be switched to monitor stereo program *or* mono cue on one side and mono program on the other. The MP 22z's recessed top mounted jacks provide room for cabling in tight DJ coffins or racks without sacrificing its compact 4" depth.

## Features

- Front Panel Replaceable Active Crossfader™
- Crossfader Contour control
- 'Dipless' 60 mm Crossfader; Optional 45 mm Crossfader
- Balanced Outputs
- Six Stereo Inputs with Trims
- Additional Aux Stereo Input
- Phono Inputs are Line Level Convertible
- Separate EQ on each Assignable Bus
- Front Panel Mic Input with EQ & Loop
- Remote Mic/Line Input
- Master Stereo Effects Loop
- Mic/Aux to Tape or Zone Switches
- Versatile Program/Cue Metering and Headphone Cueing
- UL/CSA/CE and 100/120/230 VAC Remote Power Supplies

Parameter	Specification	Limit	Units	Conditions/Comments
Gain (Master and Zone Outputs)				1 kHz, EQ centered, all Levels Max
.....Phono/Line	48 / 16	1	dB	
.....Line and Aux Line	16	1	dB	
.....Main Mic	8 / 53	1	dB	Min/Max
.....Remote Mic	6.5 / 42	1	dB	Min/Max
.....Mic and Master Loops	10	1	dB	
Input Impedance: Line	6.5k	20%	$\Omega$	
.....Phono/Line	47.5k	1%	$\Omega$	Shunted by 200 pf
.....Aux Line	20k	1%	$\Omega$	
.....Main Mic	1.2k	min	$\Omega$	
.....Remote Mic	16k	10%	$\Omega$	@ 1 kHz
.....Master Loop	8k	min	$\Omega$	
Max Input Level: Line	22 / 16	1	dBu	Trim @ -6 dB / Trim @ Max
.....Phono (1kHz)	77 / 160	5%	mV	Trim @ -6 dB / Trim @ Max
.....Main Mic	+14 (-21)	1	dBu	Min gain (Max gain)
.....Remote Mic	+16 (-10)	1	dBu	Min gain (Max gain)
Output Impedance: Master	100	1%	$\Omega$	Each leg to ground
.....Zone, Tape & Master Loop	300	1%	$\Omega$	
.....Mic Loop	100	1%	$\Omega$	
.....Headphone	0.8	max	$\Omega$	
Max Output Levels:	22	1	dBu	2k load
.....Headphone	100 / 190	typ	mW	600 $\Omega$ load / 150 $\Omega$ load
Infrasonic Filter	15	3%	Hz	18 dB/oct, Butterworth
Frequency Response	15-65 kHz	+0/-3	dB	Line to Master
THD+Noise	0.02	.01	%	+4 dBu, 20-20 kHz, Line to Master
IM Distortion (SMPTE)	0.01	0.01	%	+4 dBu, 20-20 kHz, Line to Master
Signal-to-Noise Ratio	re +4 dBu; 20 kHz noise BW, Input fader Max, Master fader & Zone Level @ unity gain			
.....Phono to Master/Zone	90	1	dB	
.....Line to Master/Zone	94	1	dB	
.....Main Mic	-113	1	dBu	Equivalent input noise
Main Output Meter: Range	-20 to +8	1	dB	
Overload Indicator	4	typ	dB	Below clipping level
RIAA Phono Stages	0.5	typ	dB	Equalization accuracy
Crosstalk	-65	2	dB	Channel to channel, 1 kHz
Input Equalizer: Bass	Shelving @ 100	5%	Hz	Range $\pm$ 8 dB
.....Mid	Peaking @ 1.6k	5%	Hz	Range $\pm$ 8 dB
.....Hi-Mid	Peaking @ 4.0k	5%	Hz	Range $\pm$ 8 dB
.....Treble	Shelving @ 6k	5%	Hz	Range $\pm$ 8 dB
Microphone Equalizer: Bass	Shelving @ 100	5%	Hz	Range $\pm$ 12 dB
.....Treble	Shelving @ 5k	5%	Hz	Range $\pm$ 12 dB
Unit: Agency Listing 120 VAC model	Class 2 Equipment			National Electrical Code
	UL			Exempt Class 2 equipment
	CSA			Exempt Class 2 equipment
Unit: Agency Listing 230 VAC model	CE-EMC			EMC directive 89/336/EEC
	CE-Safety			Exempt per article 1 of LVD 73/23/EEC
Power Supply: Agency Listing				Class 2 equipment
.....120 VAC model	UL			File no. E88261
	CSA			File no. LR58948
.....230 VAC model	CE-EMC			EMC directive 89/336/EEC
	CE-Safety			LV directive 73/23/EEC
Power Supply Requirement	18 VAC	0.1	Vrms	With center tap (RS 1 Power Supply)
Maximum Current	750		mA	RMS current from remote supply
Unit: Size	7"H (4U) x 19"W x 4"D			(17.8 cm x 48.3 cm x 10.2 cm)
.....Weight	9 lb w/o RS 1			(4.1 kg)
Shipping: Size	11" x 23" x 16"			(27.9 cm x 58.4 cm x 40.6 cm)
.....Weight	16 lb			(7.3 kg)

## Block Diagram

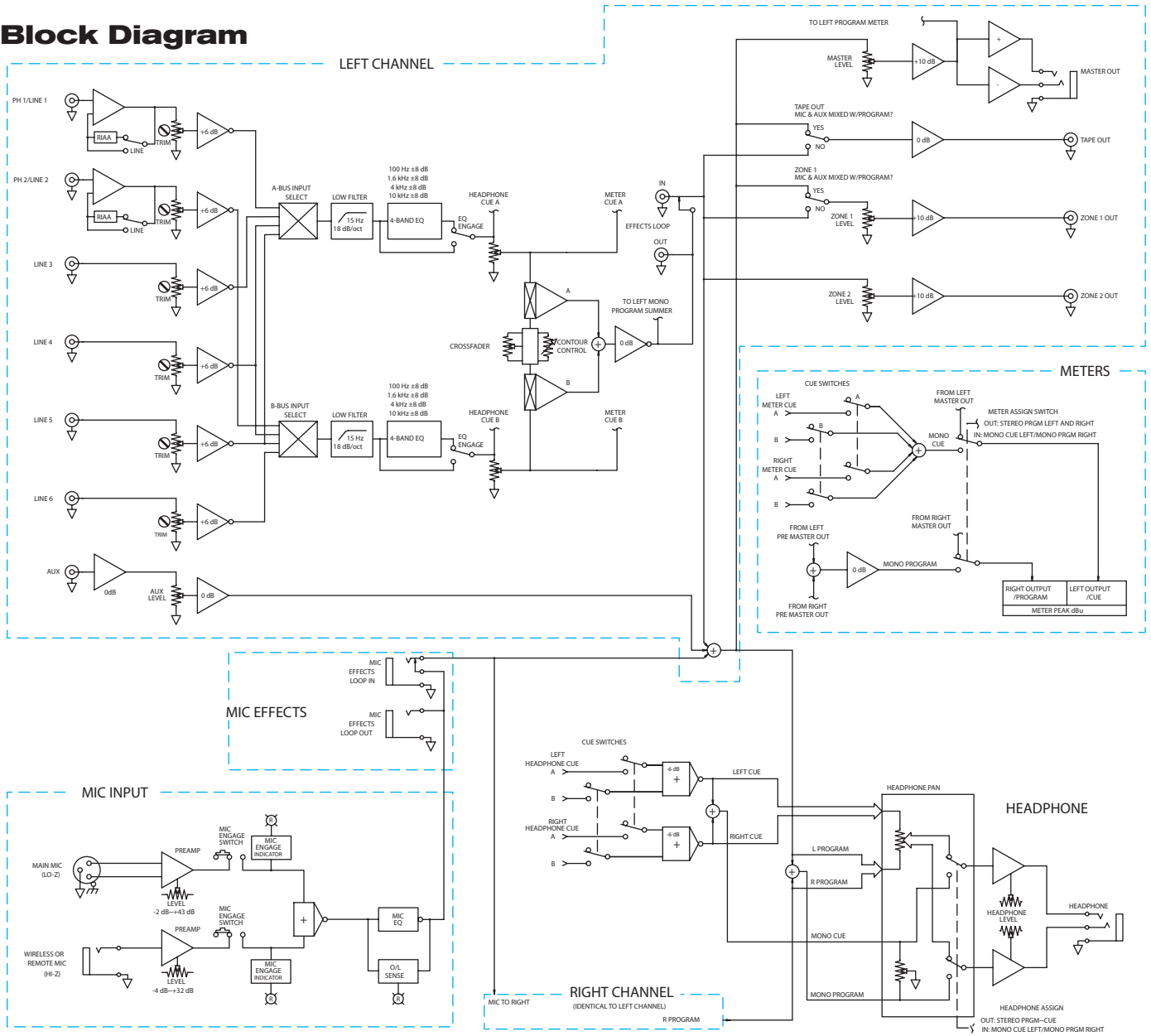

## Application Information

The MP 22z provides two sets of EQ controls, four bands each, connected with each Input fader. Sensibly placed center frequencies provide optimum control over a wide range of input devices. A tape deck on Input A, for instance, can be equalized to sound similar to a CD player on Input B for smoother crossfades. Many DJ's prefer to drop the leading Bass control during beat-matching, and bring it back up after the crossfade for a more professional mix.

The MP 22z has a dual purpose metering system. Through the meter source selector it can be changed from peak program in stereo, to mono cue on the left and mono program on the right. This allows Input Levels to be matched before Crossfading.

Separate Main Mic and Remote Mic Engage buttons with flashing indicators leave no question as to whether a mic is on or not.

The Aux Line Input has its own Level control and sums with the other program material before the Master Level fader.

Both Tape and Zone 1 Outputs can have the Mic and Aux Input signals removed by rear panel switches.

The two Zone Outputs have separate front panel Level controls. The Master Outputs are balanced ¼" TRS (tip-ring-sleeve), allowing long cable runs to an equalizer or amplifier. Unbalanced ¼" TS (tip-sleeve) cables may be used for short runs when necessary.

**Top View**

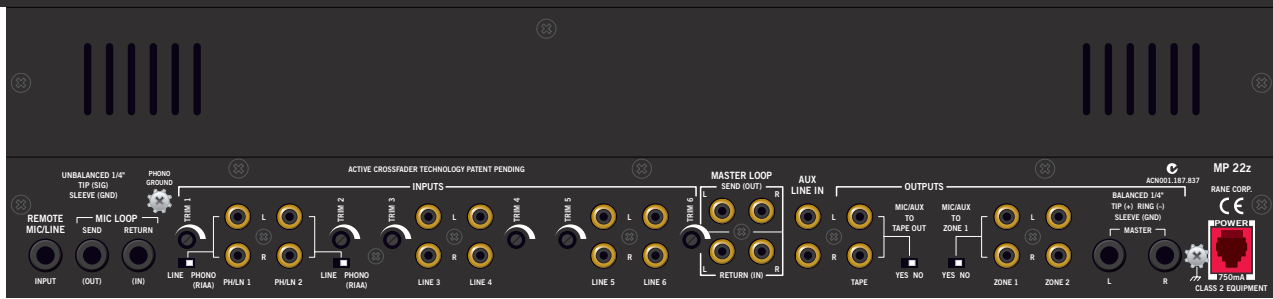

**Side View**

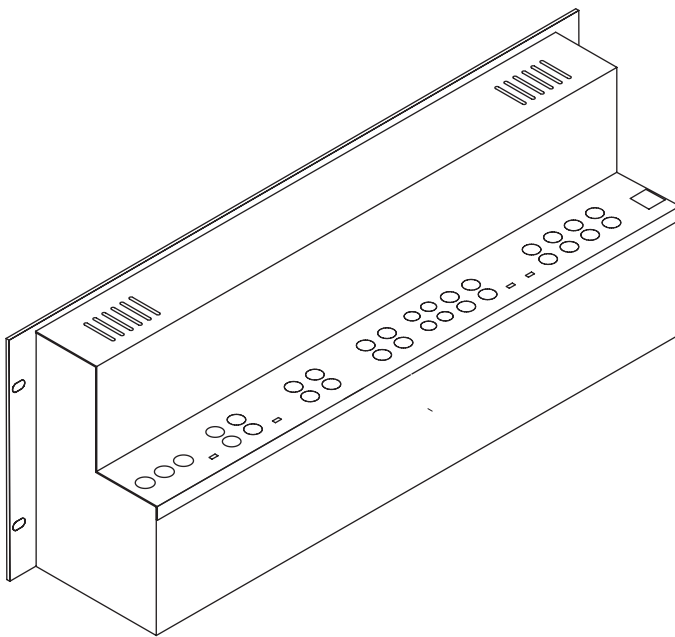

**Architectural Specifications**

The mixer shall have two (2) stereo mixing buses, each equipped with high quality 60 mm faders. Separate equalization shall be provided for each bus with a 4-band equalizer. Smooth and silent active VCA-controlled crossfading between the input buses shall be included. A crossfader contour control shall be included. There shall be two (2) stereo phono inputs which can be converted to line level, and four (4) stereo line level inputs. Provisions shall exist for simultaneous use of two microphones, with 2-band equalization and an external processing loop. A master effects loop shall be provided. Three stereo outputs shall be provided with individual level controls, comprised of Master and two Zones. Program metering shall be via a stereo LED meter. Complete cueing and headphone monitoring system shall be provided. Infrasonic and phono RFI filters shall be built-in.

The unit shall be exempt from agency safety requirements and powered from a UL listed, CSA certified (120 VAC) or CE approved (230 VAC) remote power supply. The unit shall be entirely constructed from cold-rolled steel, and mount into a standard 4U EIA rack.

*The unit shall be a Rane Corporation Model MP 22z.*

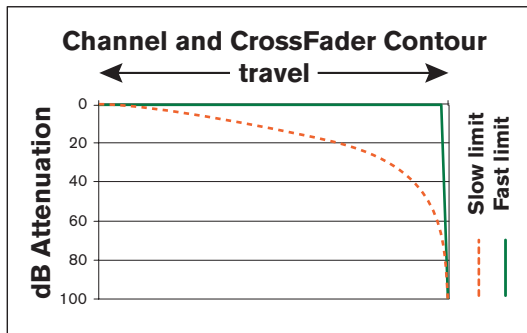

Figure 1

**Accessories**

- F 45 Fader Kit - 45 mm Crossfader Replacement
- F 60 Fader Kit - 60 mm Crossfader Replacement