

General Description

Following the success of the MP 24 DJ mixer, Rane presents the MP 22. Now smaller systems and budgets can take advantage of Rane quality and performance. The MP 22 features six stereo Inputs with individual Trims. Each of the two assignable mixing buses contains its own defeatable four band EQ, allowing separate equalization for different sources. All of the fader controls feature protective dust dams, and the rugged studio-quality Crossfader is front panel replaceable. Each of the two Phono (RIAA) Inputs can switch to CD (Line Level) use via rear panel switches. Both Mic Inputs have Bass and Treble controls as well as an Effects Loop. The MP 22

also features a second Remote Mic/Line Input and a stereo Aux Line Input. Master Outputs include a stereo Master Loop for equalization or processing, as well as two separate Zone Outputs. The Tape Output and Zone 1 can be individually switched to include the Main Mic signal with the program signal. The MP 22 doesn't scrimp on its powerful Headphone Cueing system. The metering can be switched to monitor stereo program *or* mono cue on one side and mono program on the other. The MP 22's recessed top mounted jacks provide room for cabling in tight DJ coffins or racks without sacrificing its compact 4" depth.

Features

- SIX STEREO INPUTS WITH TRIMS
- ADDITIONAL AUX STEREO INPUT
- PHONO INPUTS LINE LEVEL CONVERTIBLE
- SEPARATE EQ ON EACH ASSIGNABLE BUS
- FRONT PANEL REPLACEABLE CROSSFADER
- FRONT PANEL MIC INPUT WITH EQ & LOOP
- REMOTE MIC/LINE INPUT
- MASTER STEREO EFFECTS LOOP
- MIC/AUX TO TAPE OR ZONE SWITCHES
- VERSATILE HEADPHONE CUEING
- PROGRAM/CUE METERING
- UL/GSA REMOTE POWER SUPPLY (120 VAC)
- CE (LOW VOLTAGE & EMC) REMOTE POWER SUPPLY (230 VAC)

Parameter	Specification	Limit	Units	Conditions/Comments
Gain (Master and Zone Outputs)				1 kHz, EQ centered, All Levels Max
.....Phono/Line	48/16	1	dB	
.....Line and Aux Line	16	1	dB	
.....Main Mic	8/53	1	dB	Min/Max
.....Remote Mic	6.5/42	1	dB	Min/Max
.....Mic and Master Loops	10	1	dB	
Input Impedance: Line	6.5k	20%	ohms	
.....Phono/Line	47.5k	1%	ohms	Shunted by 200 pf
.....Aux Line	20k	1%	ohms	
.....Main Mic	1.2k	min	ohms	
.....Remote Mic	16k	10%	ohms	@ 1 kHz
.....Master Loop	8k	min	ohms	
Max Input Level: Line	22 / 16	1	dBu	Trim @ -6 dB / Trim @ Max
.....Phono (1kHz)	77 / 160	5%	mV	Trim @ -6 dB / Trim @ Max
.....Main Mic	+14 (-21)	1	dBu	Min Gain (Max Gain)
.....Remote Mic	+16 (-10)	1	dBu	Min Gain (Max Gain)
Output Impedance: Master & Zone	300	1%	ohms	
.....Tape & Master Loop	300	1%	ohms	
.....Mic Loop	100	1%	ohms	
.....Headphone	0.8	max	ohms	
Max Output Levels:	22	1	dBu	2k Load
.....Headphone	100 / 190	typ	dBu	600 Ohm Load / 150 Ohm Load
Infrasonic Filter	15	3%	Hz	18 dB/Oct, Butterworth
Frequency Response	15-65 kHz	+0/-3	dB	Line to Master
THD+Noise	0.02	.01	%	+4 dBu, 20-20 kHz, Line to Master
IM Distortion (SMPTE)	0.01	0.01	%	+4 dBu, 20-20 kHz, Line to Master
Signal-to-Noise Ratio	re +4 dBu			
.....Phono to Master/Zone	90	1	dB	20 kHz Noise Bandwidth, Input Fader Max, Master Fader & Zone Level @ Unity Gain
.....Line to Master/Zone	94	1	dB	
.....Main Mic	-113	1	dBu	Equivalent Input Noise
Main Output Meter: Range	-20 to +8	1	dB	
Overload Indicator	4	Typ	dB	Below Clipping Level
RIAA Phono Stages	0.5	Typ	dB	Equalization Accuracy
Crosstalk	-65	2	dB	Channel to Channel, 1 kHz
Input Equalizer: Bass	Shelving @ 100	5%	Hz	Range ±8 dB
.....Mid	Peaking @ 1.6k	5%	Hz	Range ±8 dB
.....Hi-Mid	Peaking @ 4.0k	5%	Hz	Range ±8 dB
.....Treble	Shelving @ 6k	5%	Hz	Range ±8 dB
Microphone Equalizer: Bass	Shelving @ 100	5%	Hz	Range ±12 dB
.....Treble	Shelving @ 5k	5%	Hz	Range ±12 dB
Unit: Agency Listing				
.....120 VAC model	Class 2 Equipment U.L. 813 Exempt CSA Exempt			National Electrical Code Class 2 Class 2
.....230 VAC model	VDE, SELV CE (EMC) CE (safety) Exempt			Safety Extra Low Voltage EMC directive 89/336/EEC Article 1 of LVD 73/23/EEC
Power Supply: Agency Listing				Class 2 Equipment
.....120 VAC model	UL listed CSA Certified			File no. E88261 File no. LR58948
.....230 VAC model	CE (EMC) CE (safety)			Meets EMC directive 89/336/EEC LV directive 73/23/EEC
Power Supply Requirement	18 VAC w.center tap	0.1	Vrms	
Maximum Current	750		mA	RMS Current from Remote Supply
Unit Construction	All Steel			
.....Size	7"H (4U) x 19"W x 4"D			(17.8 cm x 48.3 cm x 10.2 cm)
.....Weight	9 lb w/o RS 1			(4.1 kg)
Shipping: Size	11" x 23" x 16"			(27.9 cm x 58.4 cm x 40.6 cm)
.....Weight	16 lb			(7.3 kg)
Note: 0 dBu=0.775 Vrms				

Block Diagram

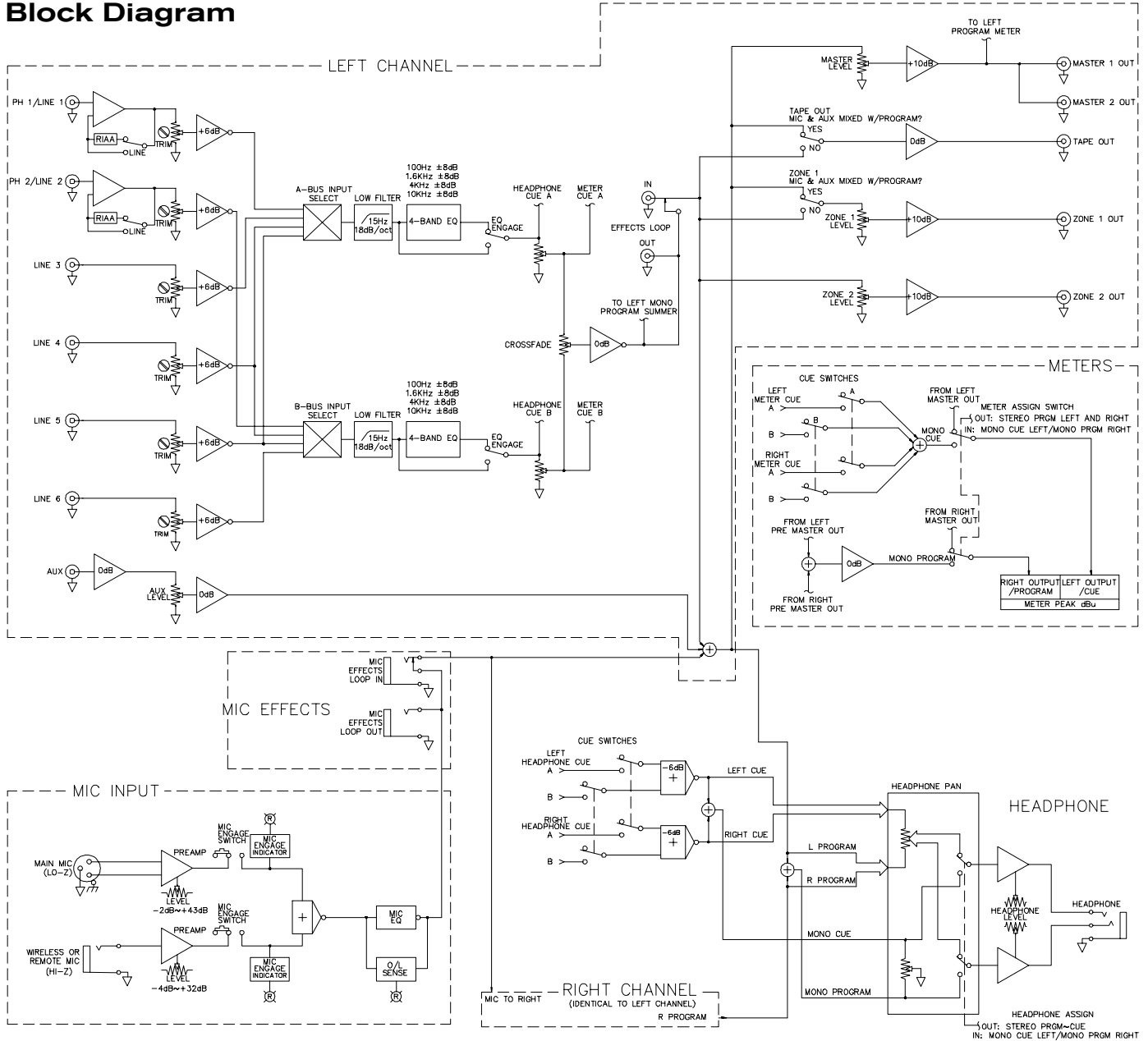

Application Information

The MP 22 provides two sets of EQUALIZER controls, four bands each, connected with each Input fader. Sensibly placed center frequencies provide optimum control over a wide range of input devices. A tape deck on INPUT A, for instance, can be equalized to sound similar to a CD player on INPUT B for smoother crossfades. Many DJ's prefer to drop the leading BASS control during beat-matching, and bring it back up after the crossfade for a more professional mix.

The MP 22 has a dual purpose metering system. Through the meter source selector button it can be changed from peak program in stereo, to mono cue on the left and mono program on the right. This allows Input Levels to be matched before Crossfading.

Separate MAIN MIC and REMOTE MIC ENGAGE buttons with flashing LEDs leave no question as to whether a mic is on or not.

The AUX LINE Input has its own LEVEL control and sums with the other program material before the MASTER LEVEL fader.

Both TAPE and ZONE 1 Outputs can have the Mic and Aux Input signals removed by rear panel switches.

MASTER 1 and MASTER 2 Output levels are linked and controlled by the MASTER LEVEL fader on the front panel. The two ZONE Outputs have separate front panel LEVEL controls.

Top View

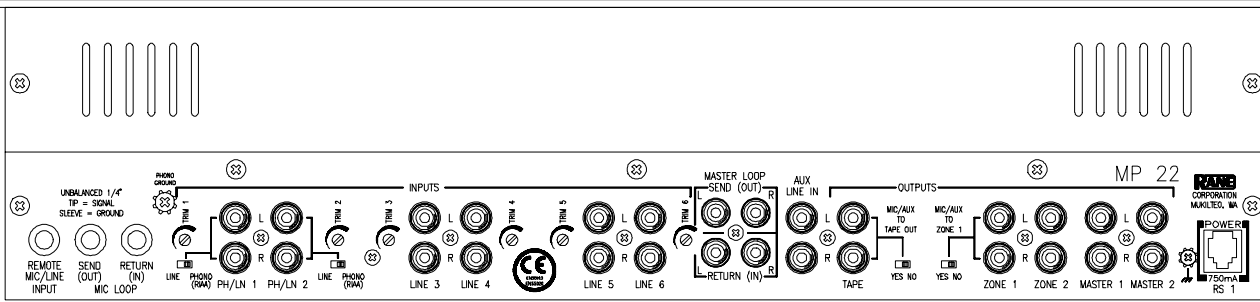

Architectural Specifications

The mixer shall have two (2) stereo mixing buses, each equipped with high quality 60mm faders. Separate equalization shall be provided for each bus with a 4-band equalizer. Smooth and silent crossfade between the input buses shall be included. There shall be two (2) stereo phono inputs which can be converted to line level, and four (4) stereo line level inputs. Provisions shall exist for simultaneous use of two microphones, with 2-band equalization and an external processing loop. A master effects loop shall be provided. Three stereo outputs shall be provided with individual level controls, comprised of Master and two Zones. Program metering shall be via a stereo LED meter. Complete cueing and headphone monitoring system shall be provided. Infrasonic and phono RFI filters shall be built-in.

The unit shall be exempt from agency safety requirements and powered from a UL listed, CSA certified (120 VAC) or CE approved (230 VAC) remote power supply. The unit shall be entirely constructed from cold-rolled steel, and mount into a standard 4U EIA rack.

The unit shall be a Rane Corporation Model MP 22.

Side View

