



General Description

The Rane MLM103 Mic & Line Mixer features six balanced studio-grade microphone inputs, and two balanced stereo line-level inputs. The microphone preamplifiers feature direct outputs. These can monitor the signal ‘pre’ or ‘post’ the mix Level control via rear panel switches. Each microphone and *stereo* line input features three-band EQ and mix level controls. Input overload indicators are peak detecting and illuminate 4 dB before clipping. Three balanced outputs are provided. A and B outputs may be used as a stereo pair in a single zone or as two independent mono zones. The AUX output is mono. All connections are via Euroblock connectors.

Inputs 1 through 6 may be individually switched between Mic or Line level via rear panel switches. Inputs operate in Mic mode with a gain range of +12 dB to 60 dB. Each *pair* of Inputs may operate with or without 12 volt phantom power via rear panel switches. When Inputs are operated in Line mode, the gain range is -4 to 12 dB. When Line mode is selected, phantom power is defeated. Each Input may be assigned to the A, B or AUX Output.

Features

- **Six Studio-grade Mic Preamplifier Inputs**
 - Mic or Line-level Operation
 - +12 volt Phantom Power
 - Continuously Variable Gain Trim
 - Direct Outputs (pre- or post- mix level)
 - A/B/AUX Assign Switches
 - Input Overload Indicator
 - EQ & Assign Switch Security Cover Included
- **Two Balanced Stereo Line-level Inputs**
 - Mono Switch
 - A/B/AUX Assign Switch
 - Input Overload Indicator
- **A/B/AUX Balanced Outputs**
 - Independent Level Control
 - 10-Segment Meter with Peak Hold
- **Euroblock Audio Connections**

Stereo Line Inputs 7 through 10 accommodate +24 dBu signal levels. The gain range is $-\infty$ to +12 dB. The A/B Assign switch for Inputs 7/8 assigns 7 to Output A *and* 8 to Output B. The A/B Assign switch for Inputs 9/10 assigns 9 to Output A *and* 10 to Output B. The Mono switch sends the *sum* of Inputs 7 and 8 (or 9 and 10) to buses A *and* B. Assigning 7/8 or 9/10 to AUX sends the *sum* of Input 7/8 (or 9/10) to the AUX Output.

The A, B and AUX Outputs feature independent level controls and 10 segment meters with peak hold. Each balanced Output provides an additional 6 dB of gain and delivers a minimum signal level of +24 dBu into a 10 k Ω load.

The MLM103 features a built-in high efficiency, universal voltage power supply that can operate in almost any country in the world. A security cover for the EQ and Assign switches is included with the unit.

This product has not been tested to the current CE requirements and is not available in markets requiring CE compliance.



Includes Security Cover for EQ and Assign Switches.

Parameter	Specification	Limit	Units	Conditions/Comments
Mic Inputs: Type	Active balanced			
.....Connectors	Euroblock			Accepts 12-24 AWG wire
.....Input Impedance Mic Mode	1.49 k	1%	Ω	745 Ω each leg, 1 kHz
.....Input Impedance Line Mode	8 k	1%	Ω	4 kΩ each leg, 1 kHz
.....Gain Range Mic Mode	12 to 60	2	dB	Min/max, 1 kHz
.....Max Input Mic Mode	+8 / -40		dBu	Min/max gain, 1 kHz
.....Gain Range Line Mode	-4 / +12	1	dB	Min/max, 1 kHz
.....Max Input Line Mode	+24 / +8		dBu	Min/max gain, 1 kHz
.....Frequency Response	50 Hz-50 kHz	+5,-3	dB	Mic gain=60 dB
	10 Hz-50 kHz	+5,-3	dB	Mic gain=12 dB
.....Equivalent Input Noise	-127	typ	dBu	Mic gain 60 dB, Rs=150Ω 20Hz-20kHz
.....Common Mode Rejection	60	min	dB	1 kHz, Rs=150Ω, gain=60 dB
.....THD+N	0.01	typ	%	Mic gain=40 dB, +4 dBu, 20 Hz-20 kHz
.....Phantom Power	12	5%	VDC	Disabled in Line mode
Stereo Line Inputs: Type	Active balanced			
.....Connectors	Euroblock			
.....Input Impedance	10 k	1%	Ω	Each leg, common mode or differential
.....Gain Range	-infinity to +12	typ.	dB	1 kHz
.....Maximum Input	+24 / +12		dBu	Min/max gain, 1 kHz
.....Frequency Response	10 Hz-50 kHz	+5/-3	dB	
.....Common Mode Rejection	40	min	dB	1 kHz, Rs=150Ω
.....THD+N	0.005	typ	%	20 Hz-20 kHz, +4 dBu, Load=10 kΩ
Tone Controls: Type	Baxandall			2 stage, bass and treble shelving
.....Boost/Cut Range	±12	typ	dB	All filters
.....Low	±6	typ	dB	Boost/cut at 300 Hz
.....Mid	±6	typ	dB	Boost/cut at 300 Hz & 3.3 kHz, center 1 kHz
.....High	±6	typ	dB	Boost/cut at 3.3 kHz
Outputs: Type	Active balanced			
.....Connector	Euroblock			Accepts 12-24 AWG wire
.....Output Impedance	200	1%	Ω	100 Ω each leg, 1 kHz
.....Maximum Output	+24	min	dBu	Load=10 kΩ, 1 kHz
.....Noise Floor	-100	typ	dB	No inputs assigned
	-89	typ	dB	Any line-level input assigned, output levels at max, 20 Hz to 20 kHz, re +4 dBu
.....Crosstalk	-80	max	dB	Any input to any output @ 1 kHz
.....Control Feed-through	-80	max	dB	All front panel assign and level controls
Meters: Type	Average dBu			
.....Range	-20 to +10		dBu	
.....Number of Segments	10			
.....Peak Hold	1 sec			
Power Supply Requirement	100 to 240		VAC	50/60 Hz, 20 watts
Unit: Conformity	FCC, cCSAus			247105
.....Construction	All Steel			
.....Size	5.25"H x 19"W x 5.3"D (3U)			(13.3 cm x 48.3 cm x 13.5 cm)
.....Weight	9 lb			(4.1 kg)
Shipping: Size	11" x 23" x 16"			(27.9 cm x 58.4 cm x 40.6 cm)
.....Weight	13 lb			(5.9 kg)

Note: 0 dBu=0.775 Vrms

Block Diagram

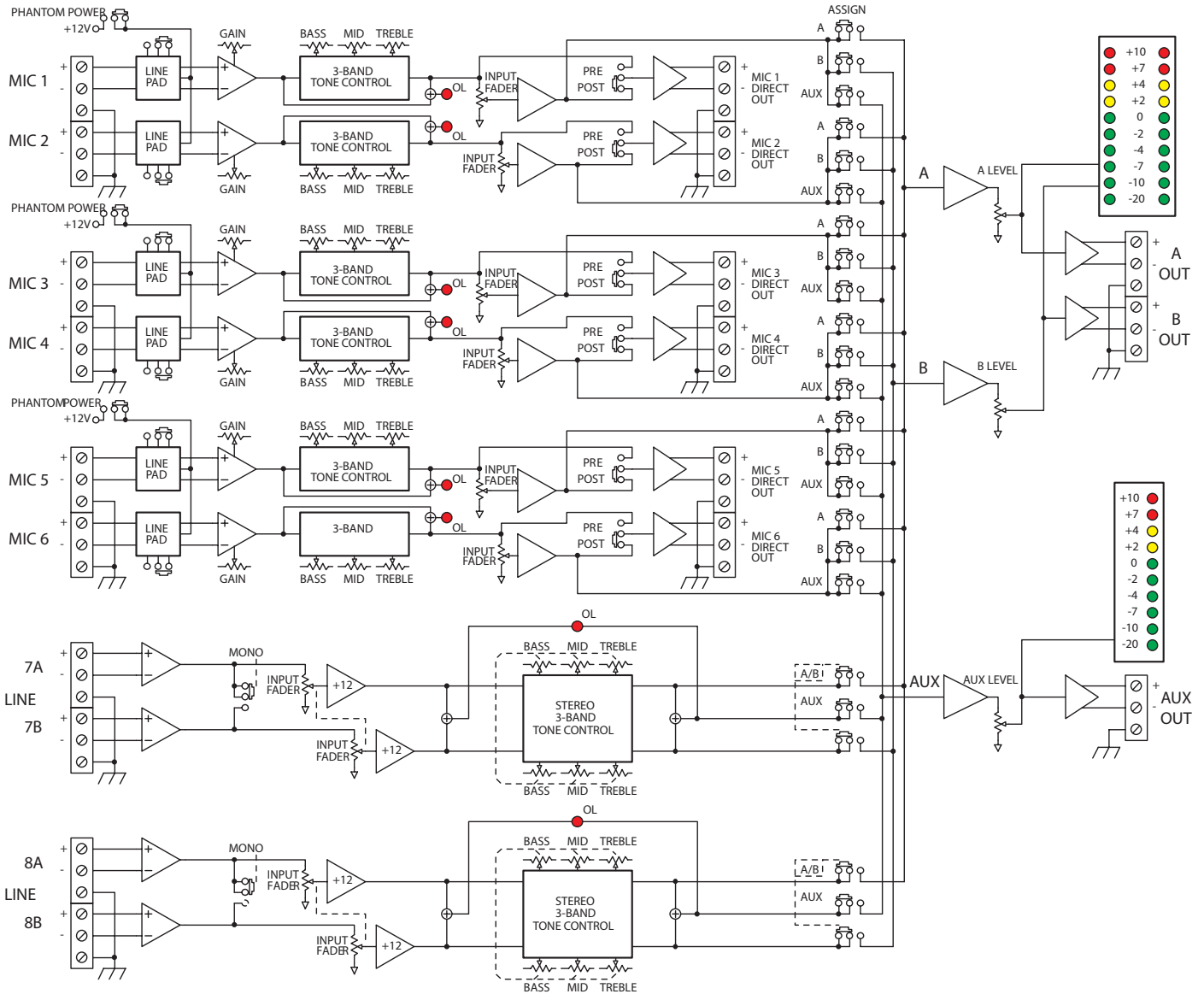

Applications

Applications can include hotels, churches, conference rooms, schools and rental sound systems. The direct outputs may be used with other mixers for applications requiring room combining and/or flexible zone distribution. The studio-grade specifications of the MLM103 allow many other applications such as sub-mixing, recording and post-production.

MLM103

MIC & LINE MIXER



Front Panel with Security Cover Installed



Rear Panel

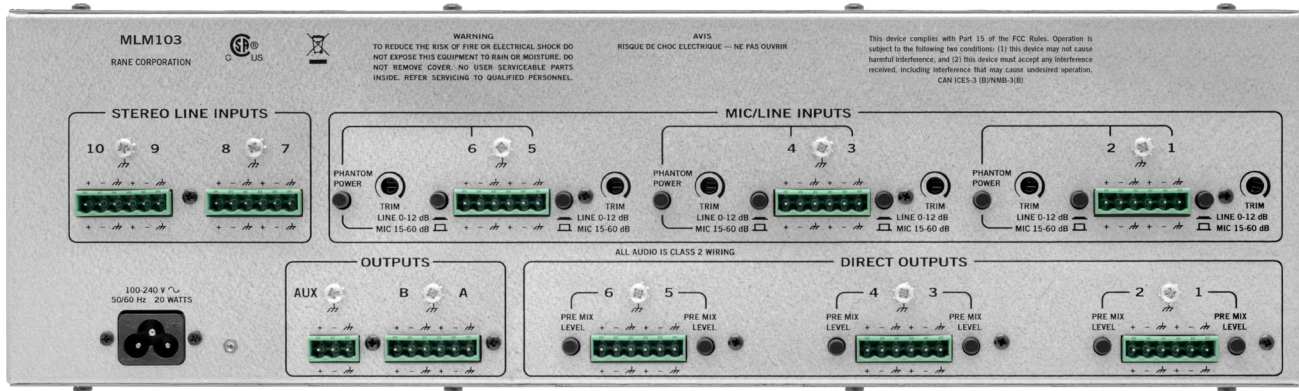

Architectural Specifications

The Mixer shall be a high performance Mic/Line Mixer featuring six balanced, studio-grade microphone inputs and two balanced, stereo line-level inputs. The microphone preamplifiers shall feature direct outputs able to monitor the signal pre- or post- the mix Level control. Each microphone and *stereo* line input shall feature three-band EQ and mix level controls. Peak detecting input overload indicators shall be provided. The Mixer shall have A, B and AUX outputs with independent level controls and 10 segment level meters with peak hold. Each balanced output shall provide an additional 6 dB of gain and deliver a minimum signal level of +24 dBu into a 10 kΩ load. All connections shall be via Euroblock connectors.

Microphone inputs shall operate in Mic mode with a gain range of +12 dB to 60 dB. Each *pair* of microphone inputs may operate with or without 12 volt phantom power. Each microphone input shall be capable of line-level operate with a gain

range of -4 to 12 dB. If Line mode is selected, phantom power is defeated. Each microphone input may be assigned to the A, B or AUX output bus.

Stereo Line inputs shall accommodate +24 dBu signal levels with a gain range is $-\infty$ to +12 dB. Each stereo line input shall feature a mono switch, A-B and AUX assign switch.

The Mixer shall include a security cover for the equalizer section and output assign switches, leaving only the level controls and metering exposed.

The Mixer shall feature a built-in, high efficiency, universal voltage power supply capable of operating from 100 to 240 VAC, 50-60 Hz. The unit shall feature an IEC socket and line cord. The unit shall meet UL/CSA and CE safety requirements. The unit shall be constructed of cold-rolled steel and mount into a standard 19" 3U EIA rack.

The unit shall be a Rane MLM103 Mic & Line Mixer.