

522-0801 DESIGNATOR: ME 60 MAIN AWC 07NOV96
 ACTION: ADDED CE TRANSFORMER OPTION

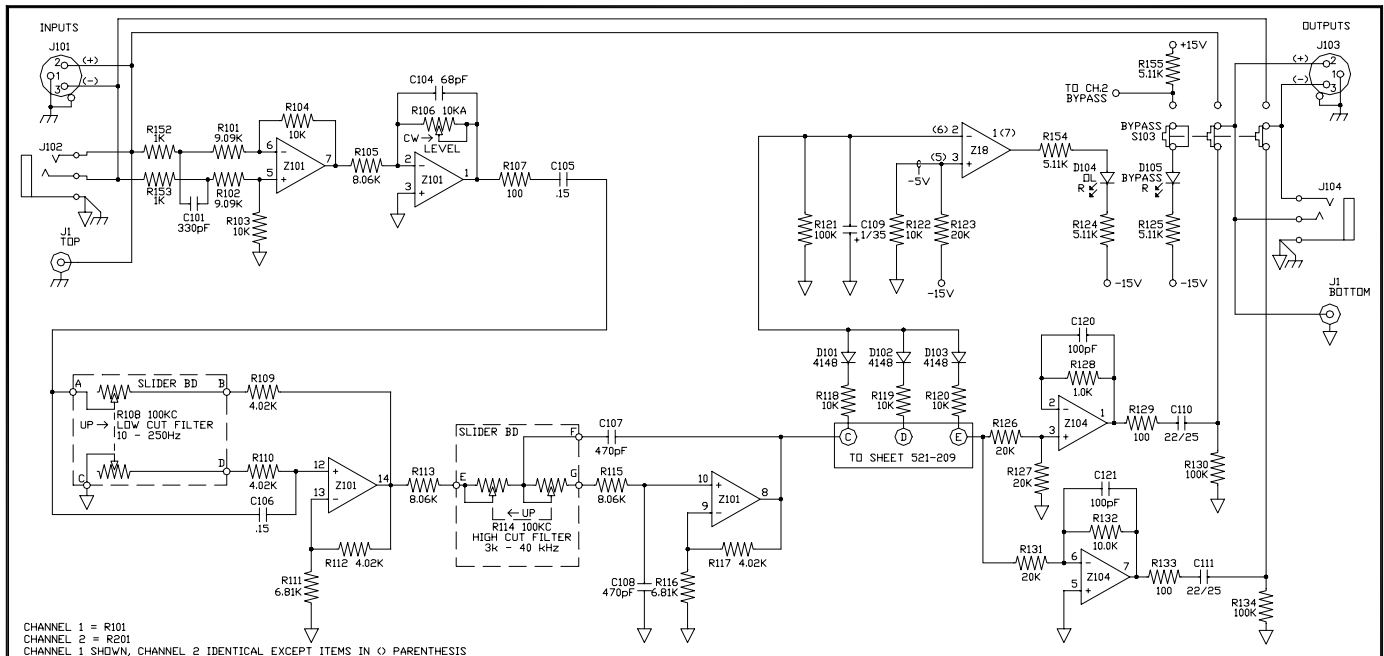

CHANNEL 1 = R101
 CHANNEL 2 = R201
 CHANNEL 1 SHOWN, CHANNEL 2 IDENTICAL EXCEPT ITEMS IN O PARENTHESIS

NOTES

- UNLESS OTHERWISE SPECIFIED:
- ALL RESISTORS 1/4W 1% METAL FILM
 - QUADS PIN 4, DUALS PIN 8 ARE +V
 QUADS PIN 11, DUALS PIN 4 ARE -V
 - ALL SW'S SHOWN IN THEIR 'OUT' OR 'OFF' POSITION
 - IC'S
 Z1-26,Z8-Z11,Z13-Z16,Z10L,Z201 = OP11 OR EQUIV
 Z7,Z12 = 4570DR EQUIV
 Z104,Z04 = 5532DR EQUIV
 Z102,Z202 = 4574DR EQUIV
 - FILTER DESIGNATION SCHEME:
 X X X X X
 DESIGNATOR
 FILTER NUMBER (01-30)
 CHANNEL NUMBER (1,2)
 COMPONENT TYPE
 EXAMPLE: C2072
 CAPACITOR, CHANNEL 2,
 FILTER 07 (100Hz), NUMBER 2

FOR 230VAC CIRCUIT CONNECTION SEE SHEET 521-374

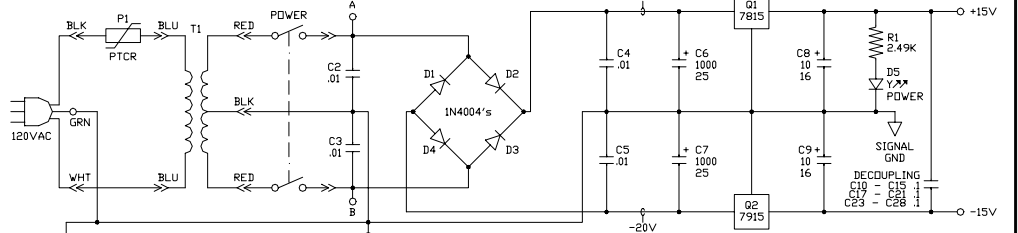

REVISIONS	REV. A	ACTION ADDED 230VAC TRANSFORMER OPTION AND WARNING MARK	DATE 08NOV96	APPROVED AWC
DRAWN	A. CLAXTON	DATE 23FEB93	CHECKED D. BOHN	DATE 12MAR93
		SHEET 1	OF 2	DO NOT SCALE DRAWING

Corp. 10802 47th Avenue West, Mukilteo
 WA 98275-5098 (206) 355-6000

TITLE		ME 60 I/O	
DRW. NO.	521-373	REV.	A

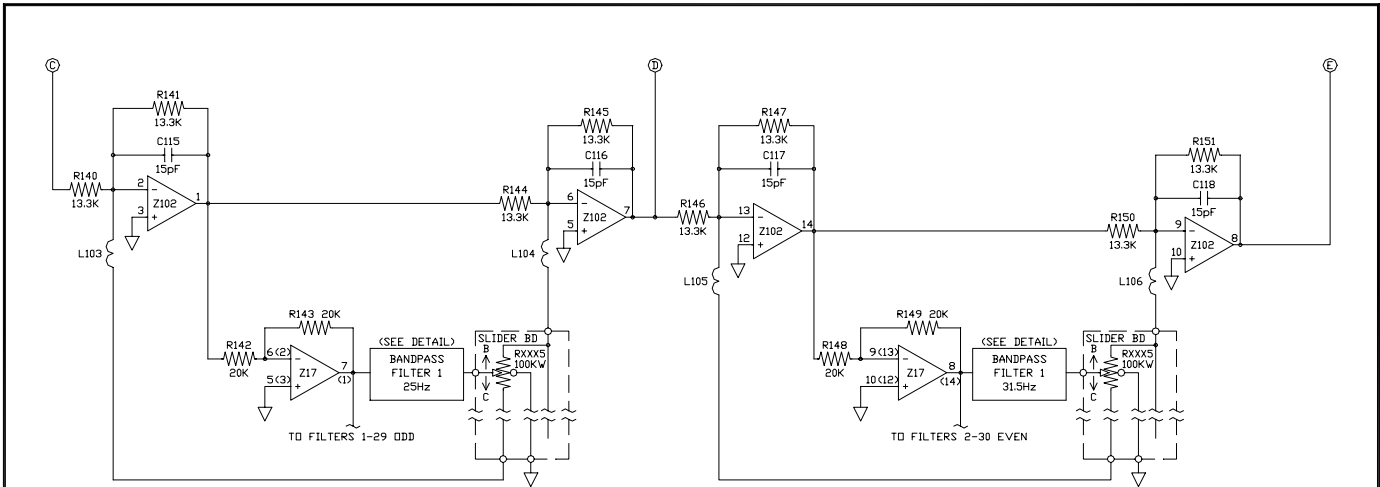

ZX CONNECTIONS

CHANNEL 1					CHANNEL 2						
FILTER	FREQ	ZX	X	Y	Z	FILTER	FREQ	ZX	X	Y	Z
1	25	Z12	2	3	1	1	25	Z22	9	10	8
2	31.5	Z13	6	5	7	2	31.5	Z22	13	12	14
3	40	Z13	2	3	1	3	40	Z3	9	10	8
4	50	Z14	6	5	7	4	50	Z3	13	12	14
5	63	Z14	2	3	1	5	63	Z3	6	5	7
6	80	Z16	2	3	1	6	80	Z3	2	3	1
7	100	Z16	6	5	7	7	100	Z2	6	5	7
8	125	Z15	2	3	1	8	125	Z2	2	3	1
9	160	Z15	6	5	7	9	160	Z1	9	10	8
10	200	Z15	9	10	8	10	200	Z1	13	12	14
11	250	Z15	13	12	14	11	250	Z4	9	10	8
12	315	Z16	9	10	8	12	315	Z4	13	12	14
13	400	Z16	13	12	14	13	400	Z6	13	12	14
14	500	Z14	13	12	14	14	500	Z6	9	10	8
15	630	Z14	9	10	8	15	630	Z5	13	12	14
16	800	Z13	13	12	14	16	800	Z5	9	10	8
17	1k	Z13	9	10	8	17	1k	Z5	6	5	7
18	1.25k	Z12	6	5	7	18	1.25k	Z5	2	3	1
19	1.6k	Z7	2	3	1	19	1.6k	Z6	6	5	7
20	2k	Z8	6	5	7	20	2k	Z6	2	3	1
21	2.5k	Z8	2	3	1	21	2.5k	Z4	2	3	1
22	3.15k	Z9	6	5	7	22	3.15k	Z4	6	5	7
23	4k	Z9	2	3	1	23	4k	Z1	2	3	1
24	5k	Z11	2	3	1	24	5k	Z1	6	5	7
25	6.3k	Z11	6	5	7	25	6.3k	Z7	6	5	7
26	8k	Z10	2	3	1	26	8k	Z8	9	10	8
27	10k	Z10	6	5	7	27	10k	Z8	13	12	14
28	12.5k	Z10	13	12	14	28	12.5k	Z9	9	10	8
29	16k	Z11	9	10	8	29	16k	Z9	13	12	14
30	20k	Z11	13	12	14	30	20k	Z10	9	10	8

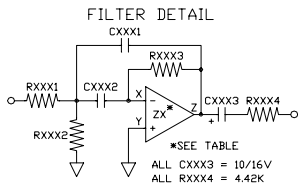

SEE NOTES SHEET 521-205

CHANNEL 1 = R101
CHANNEL 2 = R201
CHANNEL 1 SHOWN, CHANNEL 2 IDENTICAL

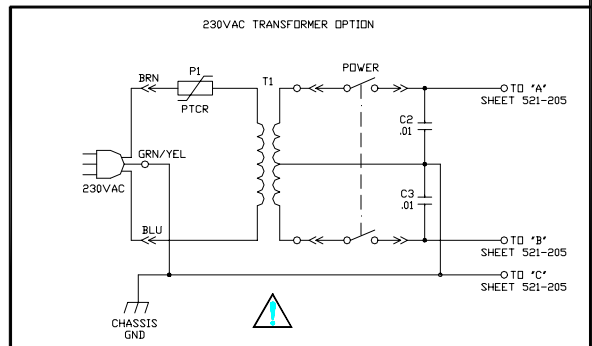

Corp. 10802 47th Avenue West, Mukilteo
WA 98275-5098 (206) 355-6000

TITLE ME 60 DETAILS	
DRW. NO. 521-374	REV. A

REVISIONS	REV. A	ACTION	ADDED 230VAC TRANSFORMER OPTION AND WARNING MARK	DATE	08OCT96	APPROVED	AWC
DRAWN	A. CLAXTON	DATE	07APR93	CHECKED	D. BOHN	DATE	07APR93
SHEET 2 OF 2				DO NOT SCALE DRAWING			