

QUICK START

Sure, you say, “it’s just a three channel amp, I’m in a hurry and I don’t need to read the manual.” But at least read this little section so you really know what to expect, and your installation can go even faster.

Be sure the Amplifier is *off* before making any connections. Euroblocks make Amplifier connection easy. They are just like “snap on” terminal blocks. The balanced Input blocks are three-terminal female connectors. The Output blocks are two-terminal female connectors.

Driving the MA 3 from a balanced source is recommended. If you must drive the MA 3 Input with an unbalanced source, we recommend using a cable that has two conductors plus a shield, and be sure to keep cable lengths as short as possible (under 10 feet). See Rane Note 110, “Sound System Interconnection” (contained in this booklet).

Nominal speaker loads should be no lower than 4 ohms per Output. If you are running series or parallel combinations, be sure and *check your total load impedance*. For constant-voltage distribution, consider using the optional TF 407 (40 W / 70.7 V) or TF 410 (40 W / 100 V) transformer. Transformers may be installed *inside* the MA 3 on any number of Output Channels required. If you intend to use constant-voltage distribution transformers, you may want to read RaneNote 136 “Constant-Voltage Audio Distribution Systems” (contained in this booklet).

Once Input and Output connections are completed, be sure all rear panel **LEVEL** controls are all the way counterclockwise. Now flip the **POWER** switch on. After a couple of seconds, slowly turn up each Channels’ **LEVEL** control to the desired gain. Maximum yields the most effective dynamic range control for the built-in Limiter). If all is well, you will hear something pleasant. If not, re-check connections, put on a better CD, and read more of the manual.

FRONT PANEL DESCRIPTION

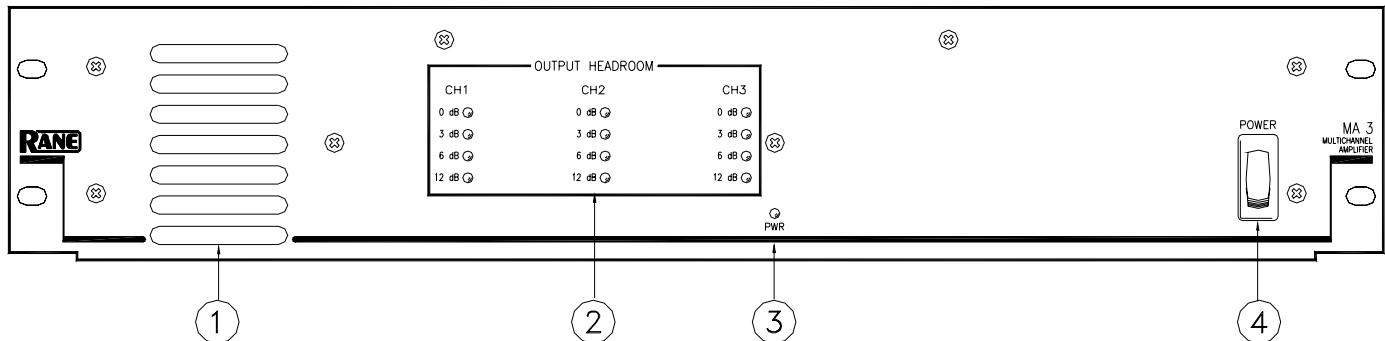

- ① **Heat tunnel exhaust vents** are located on the left of the unit. Large aperture vent slots are used for low noise. Air is taken in at the back of the unit and exhausts out the front. When installed in a rack, make sure there is ample room for air to exit. The sealed heat tunnel design does not require the use of an air filter.
- ② **OUTPUT HEADROOM meters** indicate the amount of remaining headroom (how much more signal can be applied before Limiting occurs).
0 dB OUTPUT HEADROOM remaining is indicated by a red indicator. When lit, any additional signal causes the Limiter to operate. It is possible to “compress” the signal as much as 20 dB with very little effect on sound quality. This gives the MA 3 the overload characteristics of a much larger amplifier, without the use of external compressors. The MA 3 was designed to be driven hard (heavily compressed signal) so it is not necessary to buy extra power to obtain the headroom required to prevent overload.
3 dB OUTPUT HEADROOM remaining is indicated by a yellow indicator. When lit, 3 dB of additional signal may be applied before Limiting.
6 dB OUTPUT HEADROOM remaining is indicated by a green indicator. When lit, 6 dB of additional signal may be applied before Limiting.
12 dB OUTPUT HEADROOM remaining is indicated by a green indicator. When lit, 12 dB of additional signal may be applied before Limiting.
- ③ **PWR:** This yellow indicator lights when power is applied to the unit. See ④ below.
- ④ **POWER switch:** This control obediently turns the MA 3 on and off every time you poke it with your finger. Poking the top half of the switch turns the unit *on* when it is off. Poking the bottom portion of the switch turns the unit *off* when it is on. All three Channels have turn-on and turn-off muting to reduce switching transients.

REAR PANEL DESCRIPTION

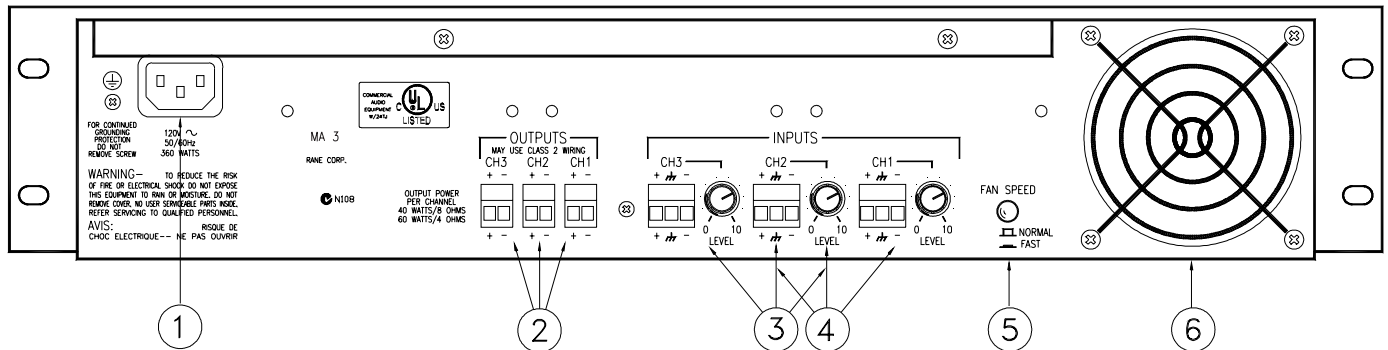

- ① **IEC cord socket:** This connector accepts a standard IEC line cord (included with 120 V domestic units). Plug this into a *grounded* AC outlet of 120 VAC (or 230 VAC if the MA 3 is internally wired for 230 V operation).
- ② **OUTPUTS:** Connect the speaker(s) to each of the three Channels by means of the Euroblock connectors with 18 to 12 AWG wire. Each Output may have an *optional* 70.7V or 100V distribution transformer installed inside the MA 3. These optional transformers are 40 watt devices with 0.5 dB insertion loss at rated power and a frequency response of 50 Hz to 15 kHz, ± 1 dB. The 70.7 V transformer kit is the TF 407. The 100V transformer kit is the TF 410.
- ③ **INPUTS** are balanced Euroblock connectors. We recommend the use of at least 18 AWG wire for reliability. Driving the MA 3 from a balanced source is recommended. If you must drive the MA 3 Input with an unbalanced source, we recommend using a cable that has two conductors plus a shield. Connect the (+) or “hot” source to the MA 3 (+) Input, the ground to the MA 3 (–) Input and connect the shield to the MA 3 shield input. **Do not** connect the shield on the source end. Shield connections go directly to chassis ground and should not be used as signal ground. Shield connection to chassis occurs via the screw found between the Input and Output connectors—keep this screw tight for improved EMI protection. When operating the MA 3 with unbalanced Inputs, be sure to keep cable lengths as short as possible. Refer to RaneNote 110, “*Sound System Interconnection*” (included in this booklet) for additional information.
- ④ **LEVEL** controls adjust the input sensitivity for each of the three Amplifiers. The internal Limiters have maximum operating range (most amount of limiting before input overload) when the LEVEL controls are set to maximum. For best *system* noise performance, the input sensitivity may be reduced to send a “hotter” signal to the Amplifier. Here we go again! You get nothing for free. There are always tradeoffs to be made (better overdrive capability *or* lower system noise). The choice depends on your application. For additional information see RaneNote 135 “*Setting Sound System Level Controls*” available from our website or upon request from the factory.
- ⑤ **FAN SPEED:** There are two fan speeds. The NORMAL setting (switch out) allows the MA 3 to deliver full rated continuous average power into 4 ohms, all Channels driven, with ambient room temperature of 22°C. Therefore, it is seldom, if ever, necessary to run the fan at the FAST speed. The exception might be a very hot environment *and* heavily compressed music into a demanding load. The only penalty for running the fan at the FAST speed is noise.
- ⑥ **Heat tunnel air intake:** The fan draws air in through the finger guard on the rear of the unit. The air flow is directed down a sealed heat tunnel and exhausts through front panel vents. No filter is required as air flow is directed through an unobstructed, sealed tunnel and will not contaminate internal circuitry.

FEATURES & APPLICATIONS

Built to be driven hard

The MA 3 Amplifier drives all three Channels at the continuous average rated power, indefinitely. It is specifically designed to operate in demanding commercial applications. Very low emissions allow the Amplifier to operate in close proximity to signal processing equipment without causing excessive interference. The CP 31, CP 52, CP 64 and SRM 66 may all operate next to the MA 3 in a rack. The high efficiency "heat tunnel" design allows the Amplifier to process severely compressed signals reliably even when installed in a rack with elevated ambient temperatures. Forced air cooling keeps heat away from other equipment.

You won't hear other Zones

The MA 3 is designed to deliver foreground music, background music and paging signals to three different Zones without annoying crosstalk. A quiet office, for example, with a paging signal only, will not hear foreground music playing in the lounge. The high capacity linear power supply incorporates three independent secondary supplies with independent bridge rectifiers and filters. The result is exceptionally good crosstalk figures even with multiple channels driving full power into 4 ohm loads.

It's OK to light the 0 dB Headroom indicator a lot

The high performance Limiter used in the MA 3 means all the available power can be delivered to the load and not simply held in reserve to avoid overload. There is no need to buy up to four times the required power just to prevent occasional system overload. The MA 3 can compress a signal with 9 dB of dynamic power range down to a signal with 3 dB of dynamic power without loss of speech intelligibility or excessive distortion.

With typical Amplifiers, when 40 watts is needed to achieve a required average SPL of 80 dB, the contractor must buy an Amplifier rated at no less than 160 watts just to maintain 6 dB of headroom. The figure below illustrates the performance of the MA 3 Limiter.

No bad "spikes"

The MA 3 is designed to operate without interruption of signal with as little as 85 VAC available (120 VAC unit). Even if the Amplifier is operating at full power, the signal will not breakup as the AC line voltage drops to 85 VAC. If the AC line drops lower than 85 VAC the signal mutes without "spikes." Once AC power is restored, the signal restarts quickly without "spikes" or signal breakup.

The good "SPiKe"

The power Amplifiers in the MA 3 are protected with National Semiconductors' proprietary SPiKe* protection circuitry. SPiKe protection offers a level of protection not available in conventional amplifiers. It has the ability to instantaneously monitor the temperature of the power device die, yielding a level of reliability not achievable with discrete designs.

80 Hz Highpass Filters

Internal jumpers allow independently selecting 80 Hz, 2nd-order Butterworth Filters for each Channel. These Filters are useful when using small bookshelf speakers or small constant voltage distribution transformers.

Optional constant voltage distribution transformers

Up to three 70.7 V or 100 V constant voltage distribution transformers may be mounted *inside* the MA 3. The optional TF 407 is a 40 watt, 70.7 V transformer with 0.5 dB insertion loss at rated power and a frequency response of 50 Hz to 15 kHz, ± 1 dB. The optional TF 410 is a 40 watt, 100 V transformer with .5 dB insertion loss at rated power and a frequency response of 50 Hz to 15 kHz, ± 1 dB. No external wiring or mounting is required.

*Spike is a registered trademark of National Semiconductor Corporation. SPiKe is an acronym for **S**elf **P**eak **I**ntermediate **(K)**e protection circuitry.

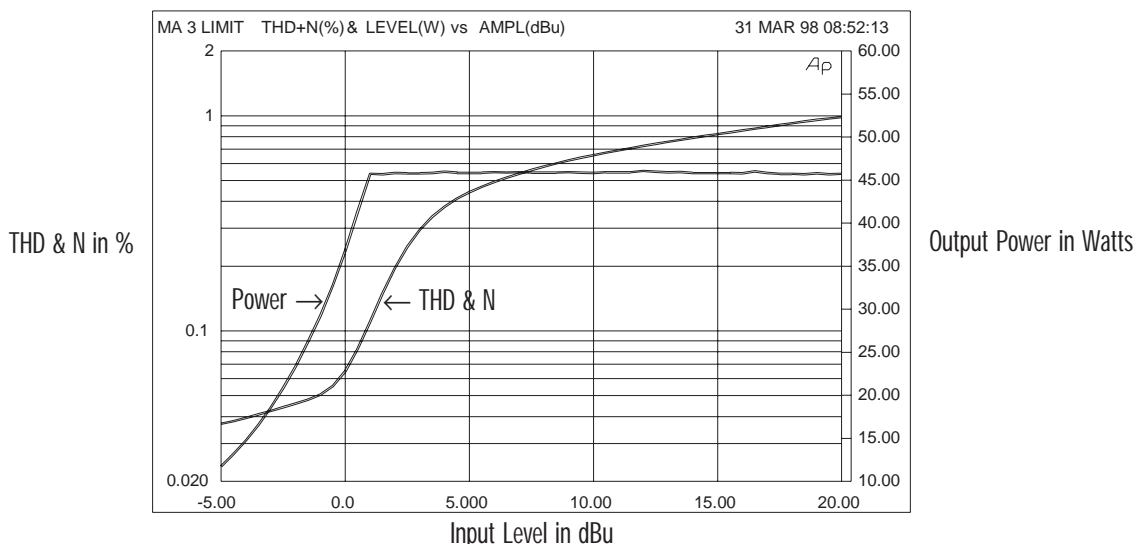

IMPORTANT SAFETY INSTRUCTIONS



1. Read these instructions.
 2. Keep these instructions.
 3. Heed all warnings.
 4. Follow all instructions.
 5. Do not use this apparatus near water.
 6. Clean only with a dry cloth.
 7. Do not block any ventilation openings. Install in accordance with manufacturer's instructions.
 8. Do not install near any heat sources such as radiators, registers, stoves, or other apparatus (including amplifiers) that produce heat.
 9. Do not defeat the safety purpose of the polarized or grounding-type plug. A polarized plug has two blades with one wider than the other. A grounding-type plug has two blades and a third grounding prong. The wide blade or third prong is provided for your safety. If the provided plug does not fit into your outlet, consult an electrician for replacement of the obsolete outlet.
 10. Protect the power cord and plug from being walked on or pinched particularly at plugs, convenience receptacles, and the point where it exits from the apparatus.
 11. Only use attachments and accessories specified by Rane.
 12. Use only with the cart, stand, tripod, bracket, or table specified by the manufacturer, or sold with the apparatus. When a cart is used, use caution when moving the cart/apparatus combination to avoid injury from tip-over.
 13. Unplug this apparatus during lightning storms or when unused for long periods of time.
 14. Refer all servicing to qualified service personnel. Servicing is required when the apparatus has been damaged in any way, such as power supply cord or plug is damaged, liquid has been spilled or objects have fallen into the apparatus, the apparatus has been exposed to rain or moisture, does not operate normally, or has been dropped.
 15. The plug on the power cord is the AC mains disconnect device and must remain readily operable. To completely disconnect this apparatus from the AC mains, disconnect the power supply cord plug from the AC receptacle.
 16. This apparatus shall be connected to a mains socket outlet with a protective earthing connection.
 17. When permanently connected, an all-pole mains switch with a contact separation of at least 3 mm in each pole shall be incorporated in the electrical installation of the building.
 18. If rackmounting, provide adequate ventilation. Equipment may be located above or below this apparatus, but some equipment (like large power amplifiers) may cause an unacceptable amount of hum or may generate too much heat and degrade the performance of this apparatus.
 19. This apparatus may be installed in an industry standard equipment rack. Use screws through all mounting holes to provide the best support.
- WARNING:** To reduce the risk of fire or electric shock, do not expose this apparatus to rain or moisture. Apparatus shall not be exposed to dripping or splashing and no objects filled with liquids, such as vases, shall be placed on the apparatus.

NOTE: This equipment has been tested and found to comply with the limits for a Class B digital device, pursuant to part 15 of the FCC Rules. These limits are designed to provide reasonable protection against harmful interference in a residential installation. This equipment generates, uses and can radiate radio frequency energy and, if not installed and used in accordance with the instructions, may cause harmful interference to radio communications. However, there is no guarantee that interference will not occur in a particular installation. If this equipment does cause harmful interference to radio or television reception, which can be determined by turning the equipment off and on, the user is encouraged to try to correct the interference by one or more of the following measures:

- Reorient or relocate the receiving antenna.
- Increase the separation between the equipment and receiver.
- Connect the equipment into an outlet on a circuit different from that to which the receiver is connected.
- Consult the dealer or an experienced radio/TV technician for help.

CAUTION: Changes or modifications not expressly approved by Rane Corporation could void the user's authority to operate the equipment.

This Class B digital apparatus complies with Canadian ICES-003.

Cet appareil numérique de la classe B est conforme à la norme NMB-003 du Canada.

WARNING

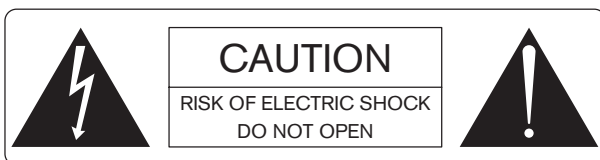

To reduce the risk of electrical shock, do not open the unit. No user serviceable parts inside. Refer servicing to qualified service personnel.

The symbols shown below are internationally accepted symbols that warn of potential hazards with electrical products.



This symbol indicates that a dangerous voltage constituting a risk of electric shock is present within this unit.



This symbol indicates that there are important operating and maintenance instructions in the literature accompanying this unit.