

GE Series Constant-Q Equalizers

General Description

The Rane GE Series Constant-Q Graphic Equalizers consists of the GE 14, a 2-Channel, 14-band, 2/3-octave design, and the GE 27, a single Channel, 27-band, 1/3-octave version. Housed in two rack-space units, these equalizers feature long throw, high resolution slide controls on each band, ensuring good resolution over its extended boost/cut range of +12dB to -15dB.

The active filter sections are of the constant bandwidth (constant-Q) variety. The bandwidth of each individual filter is guaranteed to be narrow enough to prevent unwarranted interaction between filters, yet wide enough to produce exactly the type of correction curve demanded by even the most unusual acoustic surroundings. This differs dramatically from conventional designs of the past encumbered with the

unfortunate characteristic of changing bandwidth with changing boost/cut amounts.

Front panel controls and indicators include an overall LEVEL control for each Channel as well as Signal present and Overload indicators. The rear of the unit provides 1/4" Tip-Ring-Sleeve connectors for Inputs and Outputs. The Inputs are fully actively balanced: the tip is the positive input, the ring negative and the sleeve is signal ground. Unbalanced sources may be connected to the GE series through the use of either 'mono' 1/4" connectors or by tying the ring to the sleeve on TRS type plugs. The outputs are active unbalanced.

Please consult the references cited on the back for additional details.

Features

- **GE 14: (2) 14-BAND, 2/3-OCTAVE CHANNELS**
- **GE 27: (1) 27-BAND, 1/3-OCTAVE CHANNEL**
- **CONSTANT-Q BANDWIDTH DESIGN**
- **1/4" TRS CONNECTORS**
- **OVERALL LEVEL CONTROLS**
- **PASSIVE BYPASS SWITCHES**
- **45mm FILTER SLIDE CONTROLS**
- **+12, -15dB BOOST/CUT RANGE**
- **GROUNDING CENTER-DETENTS**
- **OVERLOAD INDICATORS**
- **SIGNAL PRESENT INDICATORS**
- **INFRASONIC FILTERS**
- **ULTRASONIC FILTERS**
- **RFI FILTERS**
- **UL LISTED**



GRAPHIC EQUALIZERS

Features and Specifications

Parameter	Specification	Limit	Units	Conditions/Comments
Equalizer:				
..... Bands: GE 14	(14) 2/3-Octave ISO Spacing			From 40Hz to 16kHz
..... GE 27	(27) 1/3-Octave ISO Spacing			From 40Hz to 16kHz
..... Type	Constant-Q			
..... Accuracy	3		%	Center Frequency
..... Travel	45		mm	Positive Grounded Center Detent
..... Range	Boost: +12; Cut: -15	+2/-1	dB	
Inputs: Type	Active Balanced/Unbalanced			
..... Connectors	¼" TRS			
..... Impedance	20k	1%	Ohms	
..... Maximum Level	+22	1	dBu	Level Control Set Less Than Unity
	+19	1	dBu	Level Control Set For Unity Gain
	+14	1	dBu	Level Control Max
Outputs: Type	Active Unbalanced			
..... Connectors	¼" TRS			
..... Impedance	100	1%	Ohms	Signal & Common to Ground
..... Maximum Level	+20	1	dBu	Level Control Max
	+18	1	dBu	Level Control Set For Unity Gain
Overall Gain Range	Off to +6	-0/+4	dB	Sliders Centered
RFI Filters	Yes			
On/Off Transient Muting	Yes			Relay Controlled
Passive Bypass Switch	Yes			
LED Thresholds: Overload	+16	1	dBu	Output or any Internal Level
..... Signal Present	-20	1	dBu	Input Level
Infrasonic Filter	20Hz, 18dB/Oct, Butterworth	3%	Hz	
Ultrasonic Filter	50kHz, 12dB/Oct	3%	Hz	
Frequency Response	20-50kHz	+0/-3	dB	
THD+Noise	0.009	.002	%	+4dBu, 20-20kHz
IM Distortion (SMPTE)	0.02	.01	%	60Hz/7kHz, 4:1, +4dBu
Signal-to-Noise Ratio	GE 14 GE 27			re +4dBu, 20kHz Noise Bandwidth
	89 94	2	dB	Sliders Centered, Unity Gain
	86 91	2	dB	Sliders Centered, Max Gain
	75 75	2	dB	Sliders Max, Unity Gain
	70 70	2	dB	Sliders Max, Max Gain
Channel Separation (GE 14)	75	5	dB	20-20kHz
Maximum Power	30		W	
Line Voltage: Domestic	95-130VAC, 50/60Hz			
..... Export	190-250VAC, 50Hz			
Unit: Construction	All Steel			
..... Size	3.5"H x 19"W x 8.5"D (2U)			(8.9cm x 48.3cm x 21.6cm)
..... Weight	9 lbs			(4.1 kg)
Shipping: Size	7" x 22" x 13"			(18cm x 56cm x 33cm)
..... Weight	12 lbs			(5.4 kg)
Note: 0dBu=0.775Vrms				

Block Diagram

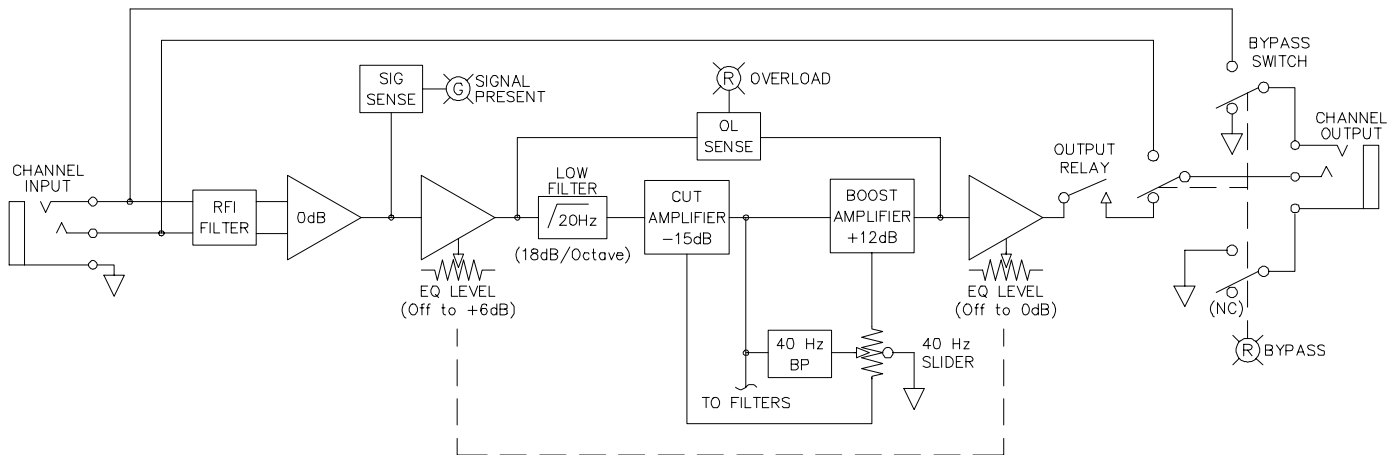

Application Information

Constant-Q graphic equalizers arose from the sound professional's need for greater control with less interaction than previously possible with conventional equalizers. Truth in slider position became a requirement. The curve traced out by the slider positions on constant-Q designs indeed represents the actual changes to the frequency response. On conventional designs they do not.

You use a constant-Q graphic the same way you use a conventional graphic. You just get the desired results quicker, with far less after-adjustment to the adjacent sliders. This eliminates a phenomenon Rane calls "equalizing the equalizer".

The accompanying figures dramatically show the advantages of constant-Q designs. A brief explanation follows describing design philosophy; for more technical information please consult the references shown on the back page.

In traditional designs the slider control is part of the bandpass filter. Consequently, whenever the slider is moved, the bandwidth changes. The output exhibits the desired bandwidth (either 1/3- or 2/3-octave) only at full boost or cut, degrading to over 1.5 octaves at moderate slider settings. Responding to this dilemma, Rane developed topology ensuring constant filter bandwidth ("Q") at all slider positions.

Another important advantage of constant bandwidth is reduction of adjacent filter overlap. Conventional designs exhibit excessive overlap at moderate slider settings. Adjusting one slider affects the adjacent neighbors, requiring re-adjustments to each. Filter overlap in Rane equalizers is dramatically less, reducing the need for constant re-adjustment of adjacent sliders. This means more effective equalization in significantly less time.

If smooth, uncolored sound quality is what is desired, then high resolution at all slider settings is what is needed. The precision constant-Q performance of Rane equalizers gives you that consistent resolution, and the difference is clearly audible.

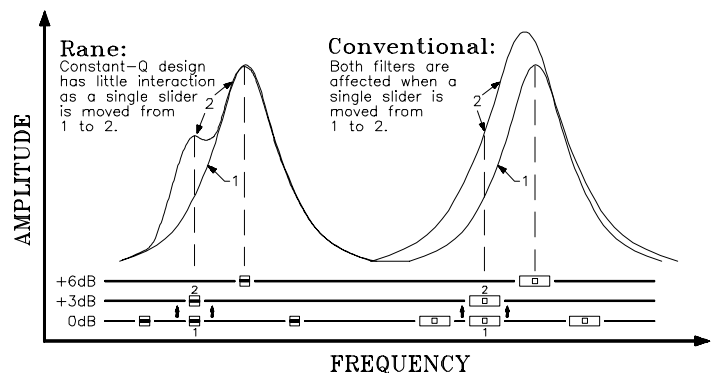
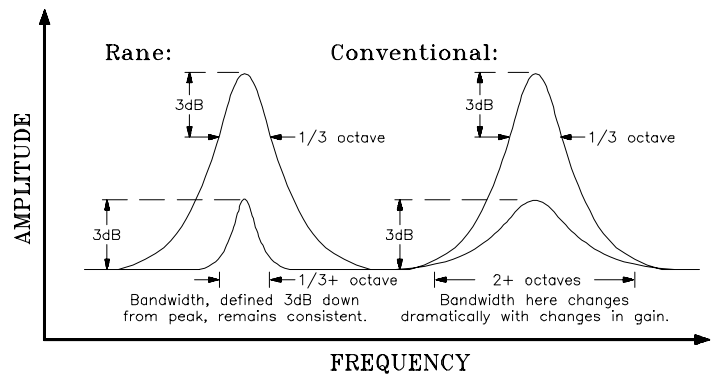



Rear Panel Details

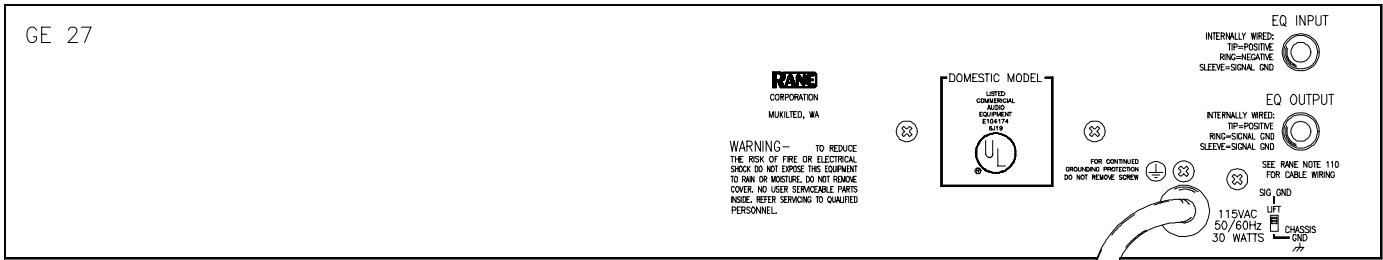
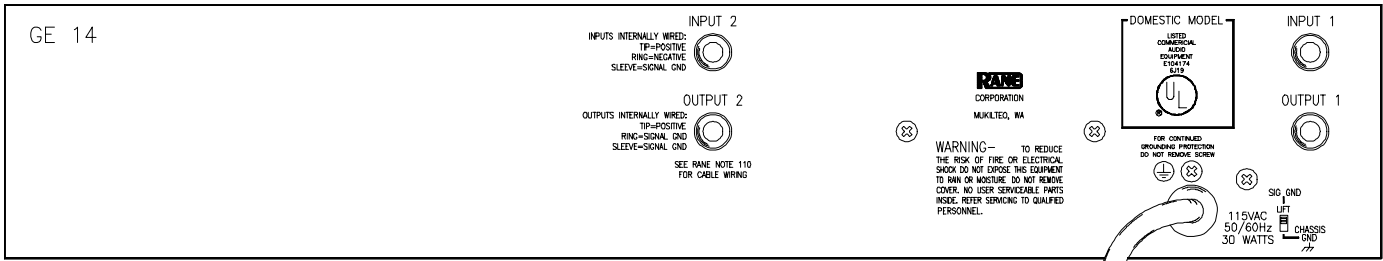

Architectural Specifications

The graphic equalizer shall be of constant-Q design to minimize interactions between adjacent bands, and contain frequency bands located on standard ISO center frequencies. Each band shall have a bandwidth of either 1/3- or 2/3-octave, as specified elsewhere. A boost range of +12dB and a cut range of -15dB shall be provided. A detented and positively grounded 0dB point shall be provided on 45mm linear sliders with dust dams.

A rotary overall level control shall be provided with a range from off to +6dB of gain.

The inputs shall be active balanced/unbalanced designs terminated with 1/4" TRS (tip-ring-sleeve) connectors. The outputs shall be active unbalanced with equal output imped-

ances (line & ground) terminated with 1/4" TRS connectors. RFI filters shall be provided. Transient on/off relay muting shall be provided. The unit shall provide a passive Bypass feature requiring no power to operate. Infrasonic and ultrasonic filters shall be built-in. LEDs shall be provided to indicate Overload and Signal Present conditions.

The unit shall be capable of operation by means of its own built-in power supply connected to 120VAC (240VAC where applicable). The unit shall be entirely constructed from cold-rolled steel.

The unit shall be a Rane Corporation GE Series Constant-Q Graphic Equalizer.

Available Accessories

- SC 3.5 Security Cover

References

1. D. Bohn, "Constant-Q Graphic Equalizers," Rane Note 101, (1982).
2. D. Bohn, "A New Generation of Filters," Sound and Video Contractor, vol. 2, pp. 36-39 (Feb. 1984).
3. T. Pennington, "Constant-Q," Studio Sound, vol.27, pp. 82-85 (Oct. 1985).
4. D. Bohn, "Constant-Q Graphic Equalizers," J. Audio Eng. Soc., vol. 34, pp. 611-626 (September 1986).
5. D. Bohn, "Exposing Equalizer Mythology," Rane Note 115, (1986).
6. D. Bohn, "Operator Adjustable Equalizers: An Overview," Rane Note 122, (1990).