

ECB 62 Base

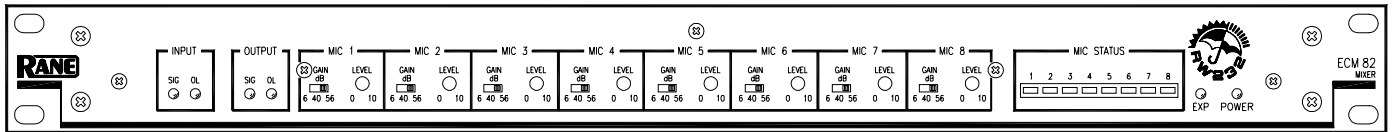

ECM 82 Mixer

General Description

Rane Corporation's updated Engineered Conference System (ECS) provides the signal processing functions required for a state of the art:

- Teleconferencing
- Videoconferencing
- Distance Learning
- Boardroom
- Courtroom

audio system. Functions include a mono or optional stereo 6 Port audio bridge (or router), up to 48 channels of automatic mic or line mixing, Multi-Zone Acoustic Echo Cancellation, video follows audio capability, integration of audio/video recording and playback equipment, programmable signal processing (EQ, delay, compression, level control), digital hybrid (in the Rane ECM 64 AD), and remote diagnostics - all available from a single manufacturer.

ECS is comprised of these two single rack space units:

- **ECB 62 Base** – 1 required per system (an optional ECS 62 Stereo Expansion card available).
- **ECM 82 Mic/Line Mixer** – up to 6 Mixers connect to a Base (optional ECA 1 Acoustic Echo Canceller card available, one in each ECM 82 Mixer).

Features

- Automatic Microphone Mixing, up to 48 Inputs
- Selective 6 Port Audio Bridge
- Programmable Input and Output Level Controls
- ECS 62 Audio Bridge Stereo Expansion Option
- RS-232 Control System Connection using Rane's RW 232
- Euroblock Audio Connections
- Minimal Rack Space Required

An optional RPD 1 Programming & Diagnostics unit may be used with a standard modem for remote programming and diagnostics.

Connecting the Rane ECM 64 and it's optional DH 1 Digital Hybrid provides high quality audio communication to the remote site through Plain Old Telephone Service (POTS).

Balanced 'Euroblock' audio connections are used throughout. RS-232 connects ECS to any control system.

RaneWare® is software operating under Microsoft Windows, allowing the units to be controlled in real time. The software's graphical interface features control of all parameters and extensive on-line help. RaneWare is included with ECS, and the latest version is downloadable from Rane's web site at www.rane.com.

Powered from UL listed, CE approved remote power supplies, all ECS components are exempt from safety agency requirements, and may be used in any installation mandating agency compliance.

US Patented Features

- Multi-Zone Echo Cancelling (MZEC™)
- Adaptive Processing of all Microphone Inputs
- Master Mic and Master Port with Delay Timers
- Adjustable Near Signal and Program Signal Offsets
- Smart Last-On

*U.S. Patent 5,848,146 on all Rane ECS products
Windows is a registered trademark of Microsoft Corporation
RaneWare is a registered trademark of Rane Corporation*



ECB 62 Base

The ECB 62 is the master controller for the ECM 82 Mixers. There are 6 Ports on the internal audio bridge, with each Port consisting of a digitally selected 5 Input audio mixer. This configuration disallows the connection of an Input to its Output, avoiding possible feedback (except Port 5). Each Port Input also provides for a selective automatic Level control.

The ECB 62 can accommodate one to six ECM 82 Mixers (8 channel mic or line mixers) on Port 1. The five other Port Inputs allow any other line level audio signals. The programmable parameters for the ECS are stored in non-volatile Memory (no batteries).

Features

- Six port selective audio bridge with stereo expansion capability
- Master processor for control, audio monitoring, & communications
- System parameters stored in non-volatile memory
- Computer-controlled Levels on all audio Inputs & Outputs
- Hardware Input Level pads on Ports 2 thru 6
- Automatic Level control on all Inputs
- Port 1 Expansion Inputs accommodate six ECM 82 Mixers
- Port 5 Input to Port 5 Output Capability
- Control network communicates with other RW 232 products
- Noise generator aids in Mic setup
- Mono Output jumpers
- Security cover included

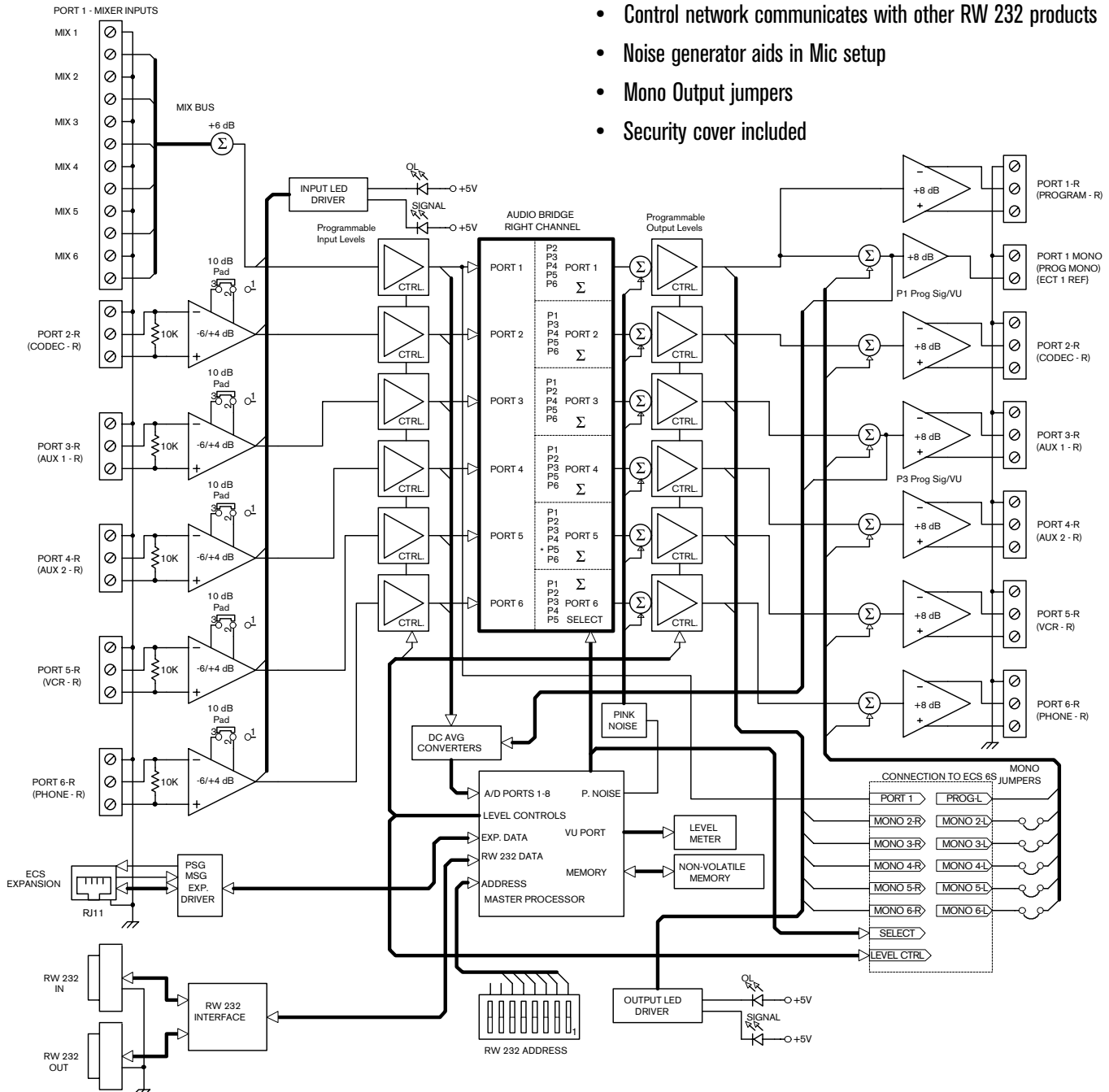

ECS 62 Optional Stereo Expansion Module

The ECS 62 is a plug-in card allowing the ECB 62 to accommodate stereo audio Inputs.

The ECS 62 installs by temporarily removing the top cover, and seating the card on top of the motherboard. Front panel trims are now accessible through a security panel, and additional connections become available at the rear panel.

Mono jumpers are provided on the Port Outputs for either mono or stereo sources. This module is designated as the left channel, while the ECB 62 euroblocks constitute the right channel.

Features

- Six Port selective audio bridge duplicates the ECB 62's audio bridge for full stereo operation
- Hardware Input Level pads
- Computer-controlled Levels on all Inputs & Outputs duplicate the ECB 62's Level controls
- Automatic Level controls on all Inputs
- Port 1's Input provided from the right channel of the ECB 62
- Mono output jumpers

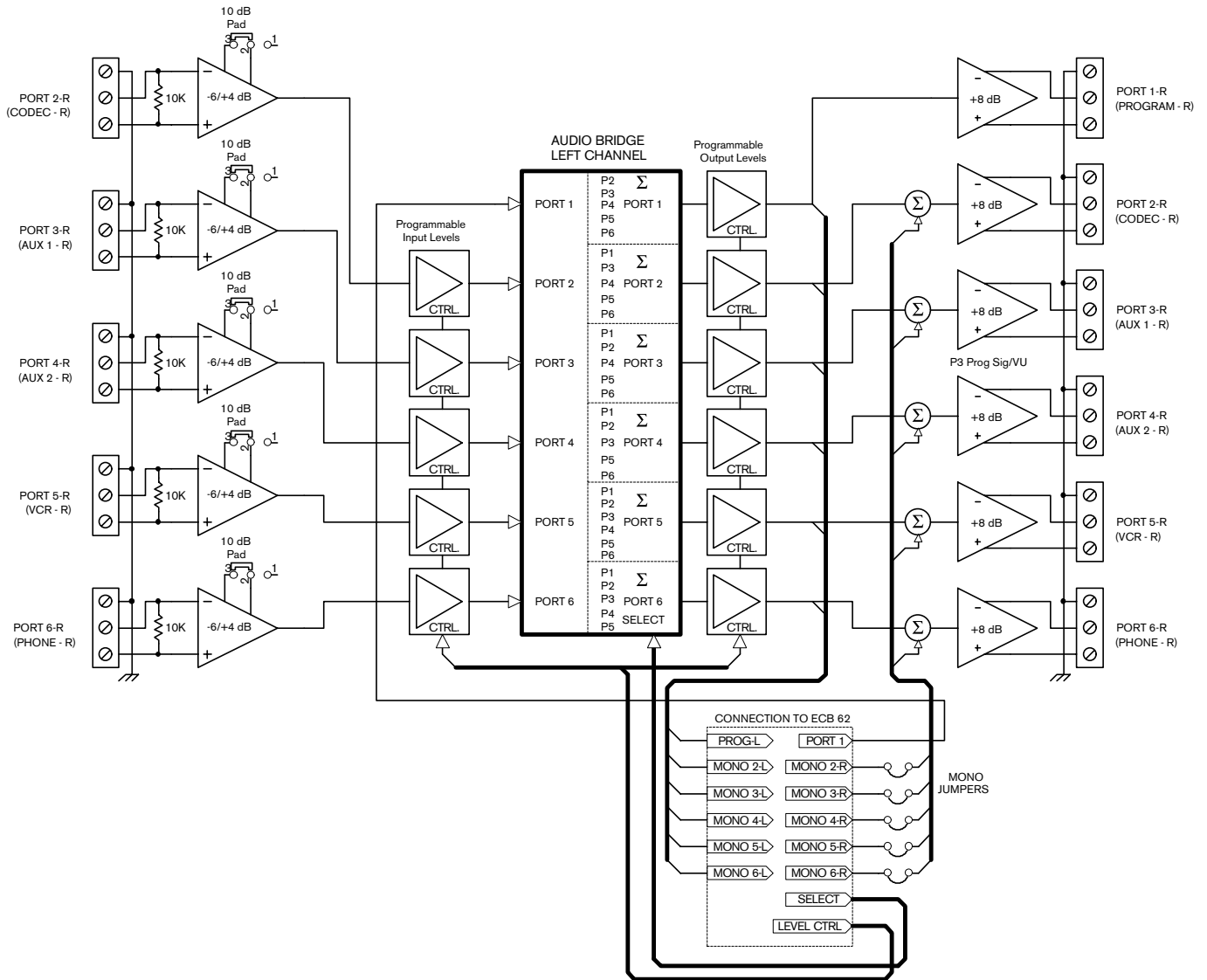



ECM 82 Automatic Mic Mixer

Features

Each Mixer provides a digitally controlled analog 8-Input automatic mixer with an optional ECA 1 Echo Canceller. The ECB 62 Base supports up to 6 ECM 82 Mixers allowing up to 48 mic or line level Inputs. The ECM 82 communicates with the ECB 62 via the Expansion Data connection. Unlike other automatic mic mixers, each Input is programmable as either a Last-On *or* Gated Output. Only Inputs placed in the Last-On mode may become the Master Channel.

All operating parameters are stored in the Base's non-volatile Memory and uploaded to the Mixers on power-up.

The ECM 82 comes with an ECS interface cable, security cover, and daisy-chain power supply cable.

- Eight channel Microphone/Line auto-mixer
- Eight programmable Input Gates
- One programmable Output Gate
- Expansion Port for cascaded Mixers
- Selectable Post- or Pre-Gate Mixed Output - all Mics, pre-Echo Canceller
- Optional ECA 1 Echo Canceller module
- Selectable NOMM function (Number Of Mics & Mixers)
- Post- and Pre-gate Outputs for each Input
- 12V Phantom Power selection for each Input
- Security Cover included

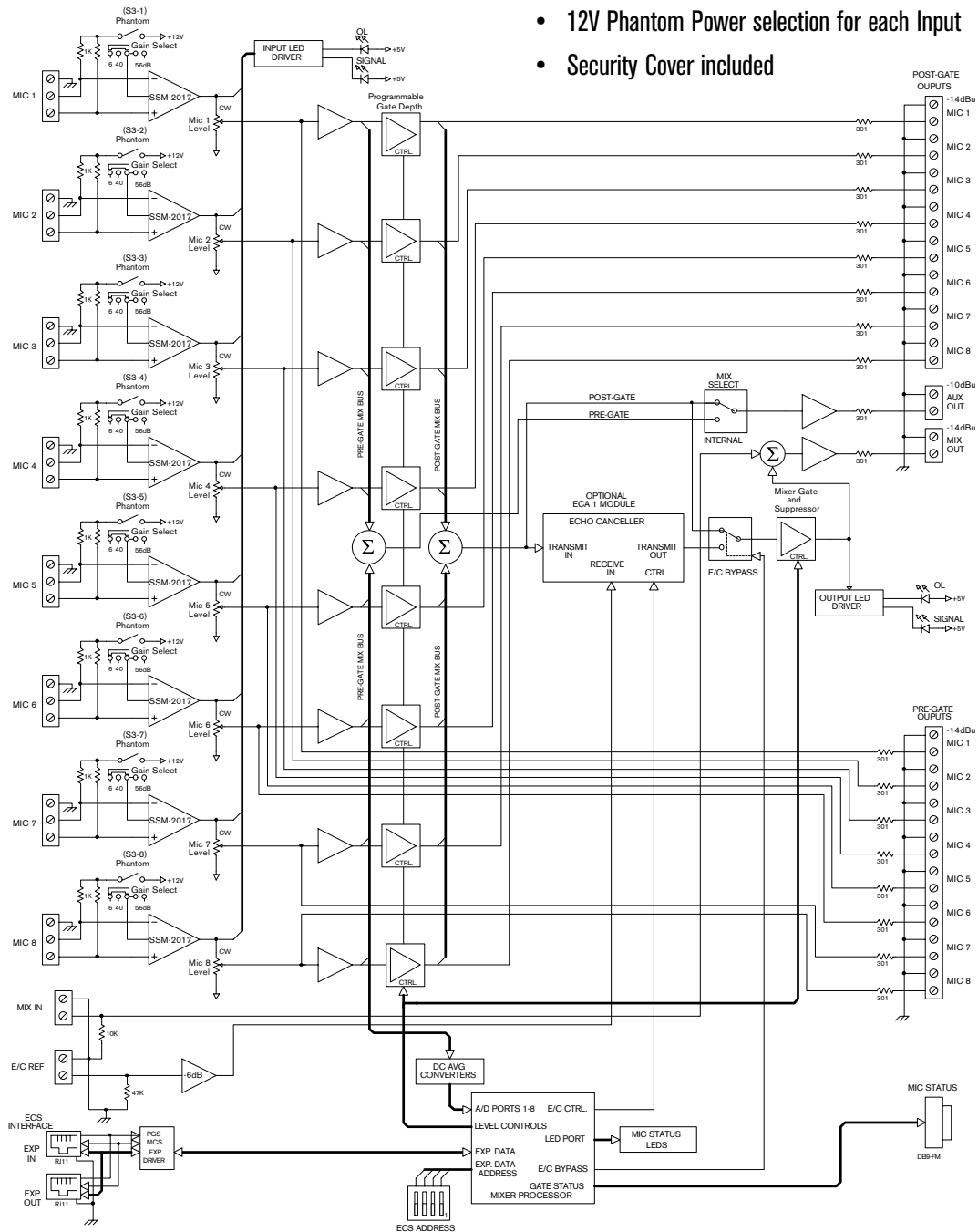

ECA 1 Acoustic Echo Canceller

The ECA 1 Adaptive DSP Acoustic Echo Canceller module is an option for the ECM 82 Mixer. The ECA 1 installs by temporarily removing the top cover, and seating the card on top of the mixer mother board. Since the Echo Canceller automatically adapts, room training is not required. This is possible through advanced digital signal processing.

The ECA 1 can be bypassed under Base control allowing the ECS to operate as a standard auto-mixer.

Features

- Adaptive DSP acoustic Echo Canceller
- Advanced DSP algorithm models and adapts to the room
- Bypass under RW 232 control
- Multi-Zone Echo Cancelling (MZEC)
- 7 kHz bandwidth
- 250 ms tail length

Multiple ECA 1 Solution

In a typical system using a single Echo Canceller, if more than three Mics are Gated On at the same time, the acoustic model may become too complex causing unwanted suppression or return echo. To eliminate this problem, Rane's innovative approach allows for an ECA 1 Echo Canceller to be installed in each ECM 82. This method is called Multi-Zone Echo Cancelling (MZEC™).

← See Location in ECM 82 Diagram

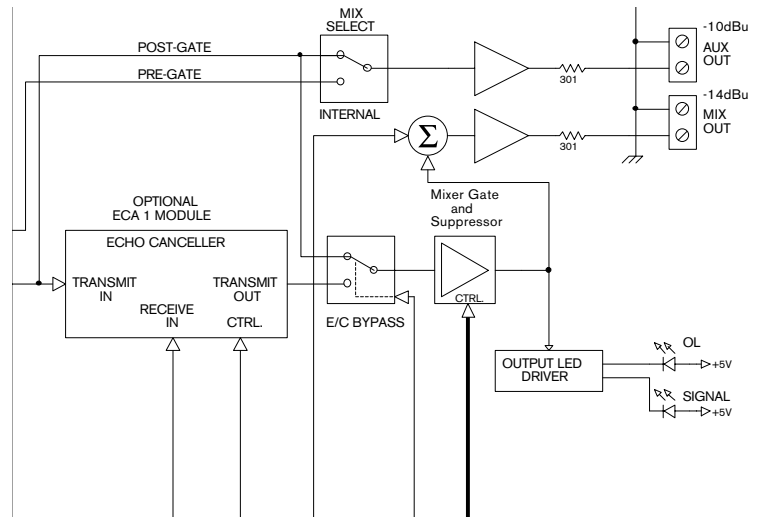

Rear Panel Details

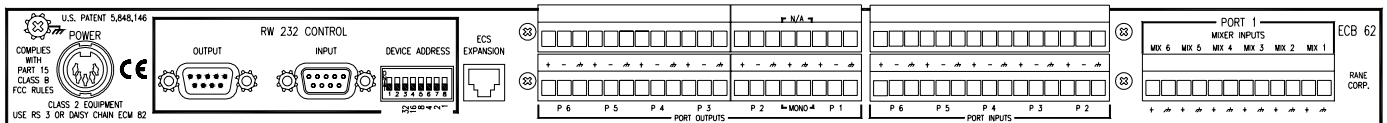

ECB 62 Base with ECS 62 Stereo Option

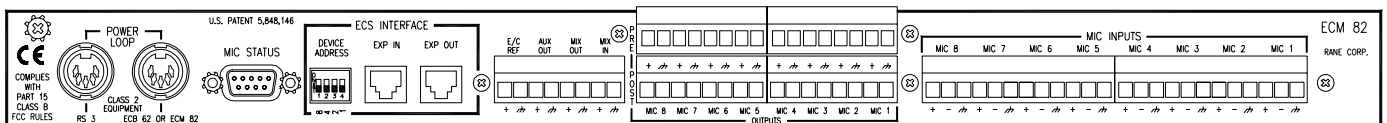

ECM 82 Mixer

ECS Architectural Specifications

The programmable conference audio system shall provide:

- A programmable audio bridge that allows for the selecting and bridging of up to six full duplex audio devices.
- The ability to receive and send mono or stereo audio signals, as required.
- Programmable automatic mixing of up to 48 microphones or line level inputs, as required.
- Up to six zones of acoustical echo cancelling with tail lengths of up to 250 milliseconds, as required.
- Remote diagnostics with password protection, as required.

Base - The audio bridge shall be computer controlled. Each section of the bridge is called a port and shall have a bandwidth of 20 Hz to 20 kHz. One of the ports shall be designated as the Room port and its input shall allow for the connection of up to six automatic microphone or line level mixers. The output of the Room port shall be designated as the Program audio source. All audio inputs, except for the Room port, shall allow for the connection of both stereo or mono audio sources and shall be an active balanced design with an input impedance of 10k ohms. All audio outputs shall supply either a mono or a stereo audio source and shall have an active cross-coupled balanced design. All audio connections shall be made using Euroblocks and have internal RFI filters.

All audio inputs and outputs of the bridge shall have programmable attenuators with 100 dB of attenuation. All audio inputs shall have selectable automatic level controls. A selectable noise source on the Program output shall be provided for alignment of the microphone gains.

Front panel LEDs shall indicate communication status, signal presence, overload, operational status and port audio level VU Meter. A port step button shall be provided to select the monitored port for the VU Meter.

The unit shall be controlled via RW 232. A device address switch, and RS-232 input and output jacks shall be provided. To communicate to the automatic mixers an Expansion Data Port shall be provided.

The programmable audio bridge shall be a Rane Corporation ECB 62 and ECS 62 Stereo Expansion Module, as required.

Mixer - The programmable audio mixer shall operate as an 8 channel manual or automatic mixer. Each channel of the mixer shall operate in either a Last On or Gated mode. When operated in a Last On mode, the mixer shall provide a means to hold the most recent active channel on. The held channel shall be called the Master Mic. When operated in a Gated mode, the mixer shall provide automatic attenuation to inactive channels and maximum gain to active channels. Detection of an active channel shall be processed by a dynamic threshold, where the threshold level must change due to the room's noise level, if another channel is active and if audio is detected at the room's loudspeakers. The Mixer's channels must not become active due to audio from the room's loudspeakers. A selectable NOM function shall be applied to the active channel level. The active Master Mic channel shall maintain a maximum level for teleconferencing.

Each mixer shall provide for the inclusion of an acoustical echo canceller and a programmable means to bypass it. The echo canceller shall be continually adaptive and not require training. Each mixer shall provide an input for the Echo Canceller Reference. Each mixer shall allow for a method or removing echo caused by the readapting of the echo canceller after a new channel becomes active and audio is detected at the room's loudspeakers. Each mixer shall allow for a programmable method to limit the maximum number of channels that can gate on at the same time.

Each mixer shall provide unbalanced outputs for Pre-Gate and Post-Gate on each channel, an unbalanced Aux output that is a selectable Post-Gate or Pre-Gate mix of all of the channels and a Mix output that is a program selectable Post-Echo Canceller or Pre-Echo Canceller unbalanced output.

To communicate to the other automatic mixers and the ECB 62 a proprietary interface shall be provided, called the Expansion Data Port.

The programmable audio mixer shall be a Rane Corporation ECM 82 and ECA 1Echo Canceller Module, as required.

Each device shall have certified compliance with FCC Part 15 for a Class B digital device, and EMCD 89/336/EEC. Each device shall be powered from a remote power supply and shall be UL listed, CSA certified and meet LVD 73/23/EEC & EMCD 89/336/EEC standards.

Each device shall be constructed entirely from cold-rolled steel and be contained in a standard E.I.A. 19" 1U rack unit.

ECS 62 Specifications

Parameter	Specification	Limit	Units	Conditions/Comments
Frequency Response	20 Hz to 20 kHz	±1 dB		
Ports 2-6 Input Impedance	10k		ohms	Active balanced
Input Pad	Switchable 0/-10		dB	
Input Attenuation	0-100		dB	Programmable
Maximum Input Level	+20		dBu	
Minimum Input Level	-14		dBu	
All Ports - Output Type	Active Balanced			Cross-coupled
THD	0.01	max	%	
CMRR	>40		dB	@ 1 kHz
Signal-To-Noise	>80		dB	@ 0 dBu ref, all on
Signal-To-Noise	>95		dB	@ 0 dBu ref, all off
Crosstalk	>70		dB	@ 1 kHz
Output Attenuation	0-100		dB	Programmable
Shipping: Size	4.5" x 12" x 14"			(11.5 cm x 30.5 cm x 35.5 cm)
.....Weight	4 lb			(1.8 kg)
<i>All Ports - Output Level @ 0 dB on Meter = 0 dBu (Max output level)</i>				



ECB 62 Specifications

Parameter	Specification	Limit	Units	Conditions/Comments
Frequency Response	20 Hz to 20 kHz	±1 dB		
Port 1 Input Impedance	10k		ohms	Unbalanced
Port 1 Nominal Input Level	-14		dBu	
Ports 2-6 Input Impedance	10k		ohms	Active balanced
Input Pad	Switchable 0/-10		dB	
Input Attenuation	0-100		dB	Programmable
Maximum Input Level	+20		dBu	
Minimum Input Level	-14		dBu	
Port 1 Mono Output Type	Unbalanced			300 ohms
Port 1 Mono Output Level	0		dBu	
All Ports - Output Type	Active Balanced			Cross-coupled
Total Harmonic Distortion	0.01	max	%	+4 dBu, 20-20 kHz
CMRR	>40		dB	@ 1 kHz
Signal-To-Noise	>80		dB	@ 0 dBu ref, all on
Signal-To-Noise	>95		dB	@ 0 dBu ref, all off
Crosstalk	>70	3	dB	@ 1 kHz
Output Attenuation	0-100		dB	Programmable
Automatic Level Control	Attack Time=1		sec	
	Release Time=1		sec	
Limiter	Attack Time=10		ms	
	Release Time=50		ms	
Overload Indicator Thresholds	20	2	dBu	Input and Output Levels
Signal Present Thresholds	-28	5	dBu	Input Level
Unit: Agency Listing				
.....120 VAC Model	Class 2 Equipment UL / CSA			National Electrical Code Exempt Class 2 equipment
.....230 VAC Model	Certified FCC part 15J CE-EMC CE-Safety			Class B Device EMC Directive 89/336/EEC Exempt Art. 1 of LVD 73/23/EEC
Power Supply: Agency Listing				
.....120 VAC Model	UL			File no. E137895
.....230 VAC Model	CSA			File no. LR53696-75
	CE-EMC			EMC Directive 89/336/EEC
	CE-Safety			LV Directive 73/23/EEC
Power Supply: Input	95-250 VAC			IEC line cord jack
.....Output	+5 VDC, 5.0 A			Pin 3
	-12 VDC, 1.5 A			Pin 4
	+12 VDC, 0.8 A			Pin 5
	Return			Pins 1 & 2
Unit: Construction	All Steel			
.....Size	1.75" H x 19" W x 8.5" D (1U)			(4.4 cm x 48.3 cm x 21.6 cm)
.....Weight	6 lb (w/o power supply)			(2.7 kg)
Shipping: Size	4.5" x 20.3" x 13.75"			(11.5 cm x 52 cm x 35 cm)
.....Weight	11 lb			(5.0 kg)
All Ports: output level @ 0 dB on meter = 0 dBu (max output level)				
Note: 0 dBu=0.775 Vrms				*Level Controls Set at "0"



ECM 82 Specifications

Parameter	Specification	Limit	Units	Conditions/Comments
Frequency Response	±1		dB	20 Hz to 20 kHz
Input Impedance	1k		ohms	Active balanced
THD	< 0.1		%	
Signal-To-Noise	>80		dB	@ 0 dBu ref
Maximum Gain	70		dB	
CMRR	>60		dB	@ 1 kHz
Min and Max Input Levels	6 dB (-20 to +10)		dBu	
	40 dB (-54 to -23)		dBu	
	56 dB (-70 to -36)		dBu	
Gate Attenuation	0 to -100		dB	
Attack time	<10		ms	
Master and Release Timer	.05 to 3		sec	
Phantom Power	12 V @ 10 ma			Selectable per Input
Mix Input	Unbalanced 10k		ohms	-14 dBu
E/C REF Input	Unbalanced 47.5k		ohms	-10 to 0 dBu
Pre- & Post-Gate, Mix Outputs	Unbalanced 300		ohms	-14 dBu Nominal @ 1 kHz
Aux Output	Unbalanced 300		ohms	-10 dBu Nominal @ 1 kHz
Automatic Adaptation Rate	<5		sec	During quiet operation
Unit: Agency Listing	Same as ECB 62			
Power Supply	Same as ECB 62			
Unit: Construction	All Steel			
.....Size	1.75" H x 19" W x 8.5" D (1U)			(4.4 cm x 48.3 cm x 21.6 cm)
.....Weight	6 lb (w/o power supply)			(2.7 kg)
Shipping: Size	4.5" x 20.3" x 13.75"			(11.5 cm x 52 cm x 35 cm)
.....Weight	11 lb			(5.0 kg)
<i>All Ports: output level @ 0 dB on meter = 0 dBu (max output level)</i>				
<i>Note: 0 dBu=0.775 Vrms</i>				

ECA 1 Specifications

Parameter	Specification	Limit	Units	Conditions/Comments
DSP Adaptive Acoustic Echo Canceller				
Frequency Response				
.....3.5 kHz operation	125 to 3625		Hz	
.....7 kHz operation	125 to 7125		Hz	
Audio Processing Delay	<50		ms	Local to Remote Output
Tail Length	Up to 250		ms	
Total Echo Cancellation	Up to 60		dB	Receive State only
Adaptive Echo Cancellation	45		dB	
Shipping: Size	4.5" x 12" x 14"			11.5 cm x 30.5 cm x 35.5 cm
.....Weight	4 lb			1.8 kg

Typical Video Conference Room Example System

The following is an ECS example application to assist designers in understanding some of the capabilities and utility of ECS. This example provides a starting point for those who are working on similar applications. This page includes a short description, followed by descriptions regarding potential Memory setups. The following pages show the system block diagram, the system wiring diagram, and RaneWare screens.

The audio system block diagram using ECS for a typical teleconferencing room is shown on the next page. This example includes:

- 8 microphones (hooked to one ECM 82A, which includes the ECA 1 Acoustic Echo Canceller.)
- Room controller (AMX or Crestron)
- Remote Diagnostics (RPD 1 and an external off-the-shelf modem.)
- Distributed room speakers for program audio (with your favorite speakers and amp)
- 4 audio sources:
 - 1) Audio from a Video Codec
 - 2) VCR 1 audio
 - 3) VCR 2 audio
 - 4) Phone add-on audio (ECM 64 with DH 1 if needed)

In this example, the room has two basic uses. One use is for conferencing (with video if needed) and a second use for audio-only conferencing using the phone add-on (POTS). Six different ECS Memories are discussed below, each allowing variations for the room's multiple uses. Of course, up to 16 different Memories are supported by ECS, all of which may be accessed via RS-232 communications. Indeed, even the 6 Memories discussed below may not cover all possible needs, they are considered here solely to initiate and inspire the multitude of possibilities.

MEMORY 1: Room Controller Operation

When Memory 1 is selected, the Room Controller can be used to enable and disable all audio sources and destinations. Use Memory 1 to allow the user to control the entire system. One may want to setup Memory 1's default settings to disable all audio devices. Thus, from the Room Controller, the user must enable Ports on the ECB 62 Base before audio is heard in the room. Also, until microphone audio on Port 1 is enabled by the user, no audio is heard at the far end. *Since the Room Controller cannot easily query for the current ECS system settings, the Room Controller and ECS units must default to the same settings. Therefore, when designing an ECS system with a room controller, both ECS and the room controller must start with the same settings.*

MEMORY 2: Conference via POTS

Memory 2 enables conferencing using the ECM 64 with the DH 1 Digital Hybrid. This Memory connects the room audio (the Base's Port 1) to the Digital Hybrid (Port 6), thus sending room audio picked up by the Mics to the far end. At the same time, this Memory connects audio being sent from the far end (Port 6's Input) to the local room speakers (Port 1's Output).

MEMORY 3: Conference via Video Codec

Memory 3 connects the room audio (Port 1) to the Video Codec (Port 2). This allows a conference via the Video Codec, instead of via the Digital Hybrid as in Memory 2. Video signals are not handled by ECS, therefore it is immaterial to ECS whether video signals are being exchanged, thus creating a videoconference.

MEMORY 4: Conference with VCR 1 audio

Memory 4 connects VCR 1 audio (Port 4) to the room speakers for local reinforcement or playback. Additionally, VCR 1 audio connects to the Video Codec thus sending VCR 1 audio to the far end (via Port 2). ECS does not accept video signals, therefore, the VCR 1 video feeds and switching for Memory 4 must be accomplished elsewhere.

MEMORY 5: Multi-way Conference or Phone add-on

Memory 5 allows a multi-way conference where the room audio (Port 1) connects to the Video Codec (Port 2) *and* to the Digital Hybrid (Port 6). This allows a 3-way conference via the Video Codec, the Digital Hybrid (POTS) and the local room.

MEMORY 16: System Setup

Memory 16 can be used to set Mic and Port gains during sound system optimization. For optimization, one might want to disable Limiters and automatic Level controls which are available on many ECS Inputs or Outputs. The other Memories could enable such processing as required.

These are just a few sample Memory setups. Up to 16 are possible. The flexibility of the Base's Ports acting as an audio bridge should now be apparent. Since the Base also communicates to the Mixer, one can also disable and enable various combinations of Mics when their use is not necessary in certain Memories or setups. Even the audio level of each source can be modified using various Memories. The Room Controller can also control individual audio source levels, thus giving the user more control — or is that an oxymoron like saying military efficiency?

The optional ECS 62 card renders the Base a stereo device allowing stereo reinforcement when needed. And since the Base supports up to six 8-channel ECM 82 Mixers - each with its own Echo Canceller - up to 48 Mic Inputs are supported.

Example Conference System Block Diagram

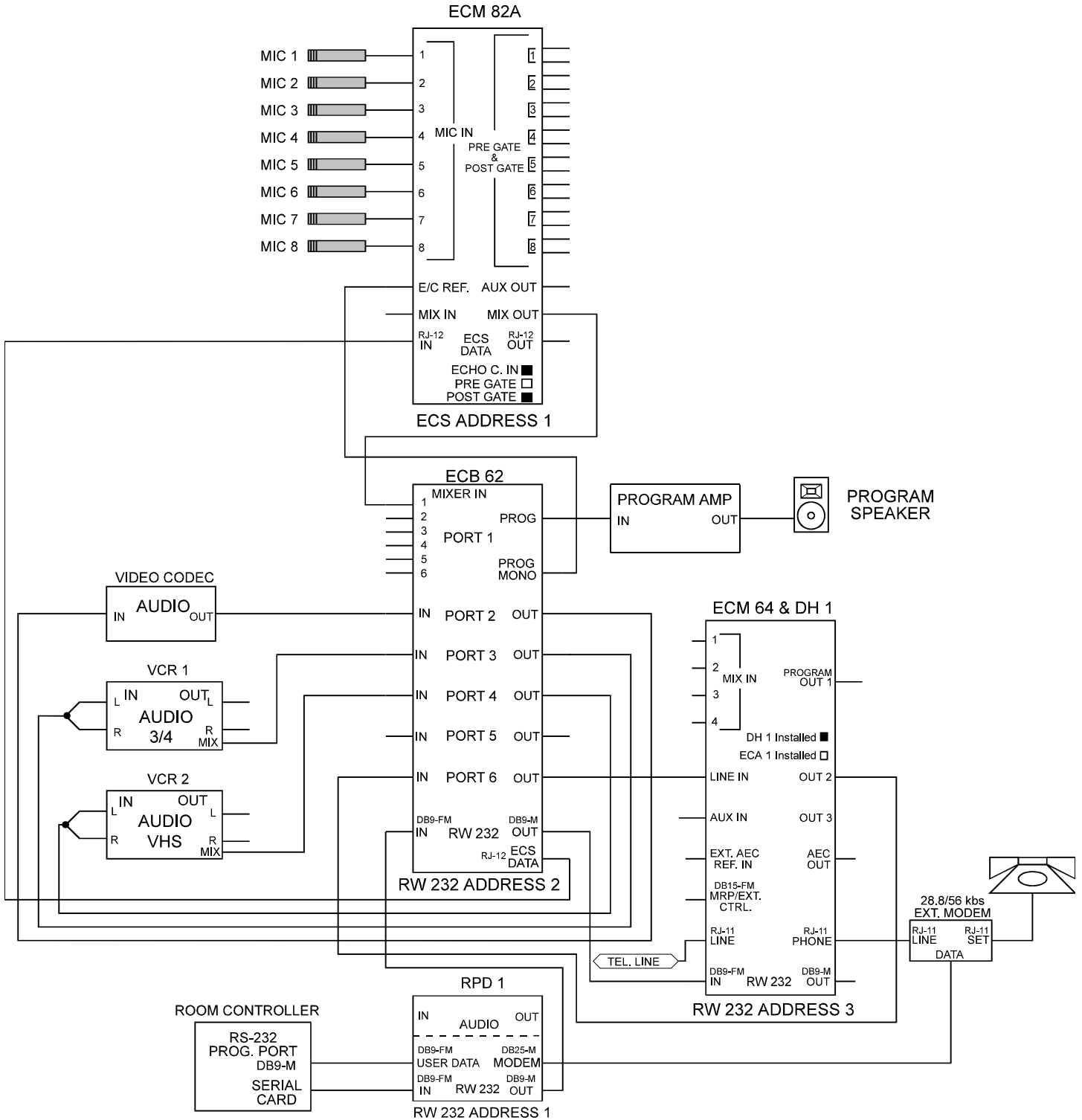



Example Conference System Wiring Diagram

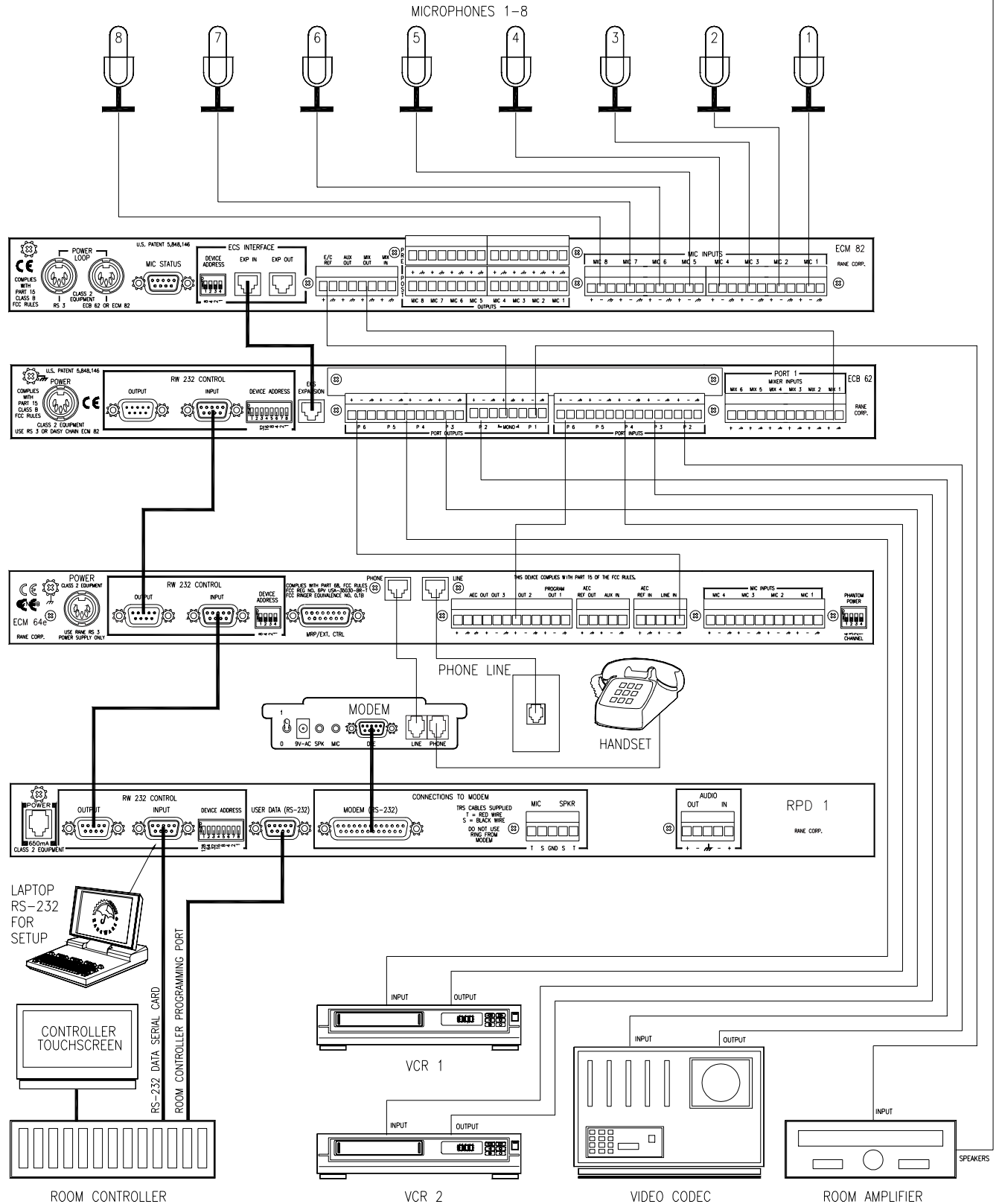



**RaneWare
Screens for
Example System**

Port | **Mixer** | **System**

ROOM

Port Inputs: Port 1 On, Port 2 On, Port 3 On, Port 4 On, Port 5 On, Port 6 On

Signal Mode: Automatic, On, Off

Threshold Level: -20 dB

Input Attenuation: 4.0dB

ROOM	CODEC	AUX1	AUX2	VCR	PHONE	Port Outputs	On
<input type="checkbox"/>	<input type="checkbox"/>	<input type="checkbox"/>	<input type="checkbox"/>	<input type="checkbox"/>	<input type="checkbox"/>	<input checked="" type="checkbox"/> Program 6.0dB	<input type="radio"/>
<input type="checkbox"/>	<input type="checkbox"/>	<input type="checkbox"/>	<input type="checkbox"/>	<input type="checkbox"/>	<input type="checkbox"/>	<input checked="" type="checkbox"/> CODEC 10.0dB	<input type="radio"/>
<input type="checkbox"/>	<input type="checkbox"/>	<input type="checkbox"/>	<input type="checkbox"/>	<input type="checkbox"/>	<input type="checkbox"/>	<input checked="" type="checkbox"/> AUX1 0.0dB	<input type="radio"/>
<input type="checkbox"/>	<input type="checkbox"/>	<input type="checkbox"/>	<input type="checkbox"/>	<input type="checkbox"/>	<input type="checkbox"/>	<input checked="" type="checkbox"/> AUX2 10.0dB	<input type="radio"/>
<input type="checkbox"/>	<input type="checkbox"/>	<input type="checkbox"/>	<input type="checkbox"/>	<input type="checkbox"/>	<input type="checkbox"/>	<input type="checkbox"/> VCR 0.0dB	<input checked="" type="radio"/>
<input type="checkbox"/>	<input type="checkbox"/>	<input type="checkbox"/>	<input type="checkbox"/>	<input type="checkbox"/>	<input type="checkbox"/>	<input checked="" type="checkbox"/> PHONE 10.0dB	<input type="radio"/>

Port | **Mixer** | **System**

Mixer: 1

Output:

Echo Canceller: Bypass, 3kHz, Enhanced

Suppression, NOMM Mode

Mixer Gate 0.0dB

Max Mics On: 3

Mic 1 Active, Mic 2 Active, Mic 3 Active, Mic 4 Active, Mic 5 Active, Mic 6 Active, Mic 7 Active, Mic 8 Active

Mic 1: Name Copy

Mic Mode: Automatic, Force On, Force Off

Automatic Threshold:

Threshold Level: -25 dB

Gate Mode: Last On, Gated

Gate Depth: 20.0dB

Gate Release: 0.30s

Port | **Mixer** | **System**

Power-Up Noise

P3 Prog Contribute

Link Prog Signal

Port 1: Suppression 0.0dB, Noise Gate 0.0dB

Master Port Delay: 0.35s

Master Mic Delay: 0.35s

Port Sig Release: 0.35s

Mic Sig Release: 0.35s

Prog Sig Release: 0.35s

Near Sig Offset: 18dB

Prog Sig Offset: 18dB

System Offset: 0dB

Prog Sig Thresh: -20 dB

