

ECB 62e Base & Security Cover

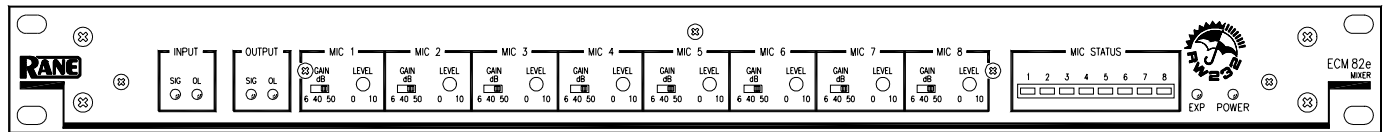

ECM 82e Mixer & Security Cover



Quick Start

The ECS Operating Manuals are split into two booklets — one for ECS hardware and one for RaneWare® software. Neither booklet includes service information. Should any unit require repair, contact the Rane factory. Telephone, fax and web info is on the rear of this manual.

Typically, only one ECM 82eA (with AEC) is required per system. If your system requires more than eight mics, you can add up to five ECM 82e Mixers (without AEC) for a total of 48 mics. The QuickAdapt™ algorithm allows a single AEC to operate the entire system. When using a single AEC with multiple mixers, daisy-chain the ECM 82e Mixers together using MIX OUT to MIX IN. The last mixer in the chain and the one that connects to the MIX 1 input on the ECB 62e must be the ECM 82eA. Only the ECM 82eA requires its AEC Reference input to be connected to the Mono output on the ECB 62e. See RW Manual-17.

Plain Old Telephone Service (POTS) type teleconferencing, also known as phone add-on, requires an additional Digital Hybrid. The Rane ECM 64e Conference System with its DH 1e Digital Hybrid module can be added to provide phone add-on support to the ECB 62e. If remote diagnostics is desired, then add a Rane RPD 1 Programming & Diagnostics unit or the Rane Via 10 Ethernet Bridge.

Since ECS is a programmable audio system, it must first be programmed before it can pass audio. When power is first applied to the ECB 62e, memory is set with all outputs muted. For a typical system configuration, recall Memory 1 and inputs will be routed to outputs. To further simplify this process, just recall Memory 16 and you are ready to adjust mic levels. See RW Manual-21 for system setup procedures. For more information there are four system applications in the RaneWare Operators Manual.

Most echo problems are caused by improper microphone placement and gain. To achieve good AEC performance, the microphones must be properly set up, as shown on page RW Manual-19 (in the ECS RaneWare Manual).

WEAR PARTS: This product contains no wear parts.

ECS Hardware Manual

This manual begins by explaining the options and internal settings for each unit, since all optional accessories must be installed and all internal jumpers set before installation of the units into equipment racks. Next are detailed descriptions of the front and rear panel features, followed by detailed block diagrams and discussions, as well as diagrams showing the signal flow making up the critical “offsets,” or thresholds used by ECS. Then comes instructions on Power, Audio & Data Connections, as well as how to set each unit’s Device Address. Complete electronic and mechanical specifications are found in the Data Sheet.

Information on installing and running the control software is found in the second booklet: *ECS RaneWare Operators Manual*.

Contents

- CUSTOMIZING ECS 2**
- ECB 62e BASE 3**
- ECS 62 STEREO EXPANSION MODULE 6**
- ECM 82e MIXER 7**
- ECA 2 ECHO CANCELLER MODULE 10**
- POWER, AUDIO, AND DATA CONNECTIONS .. 11**
- SETTING THE DEVICE ADDRESS 13**

*U.S. Patent 5,848,146 on all Rane ECS products
Windows is a registered trademark of Microsoft Corporation
RaneWare is a registered trademark of Rane Corporation*

CUSTOMIZING ECS

Before installing ECS components, there are a few options that need to be determined first. *All but one of these require removing the top covers before installation.*

ECS 62 STEREO EXPANSION MODULE

See the description and installation diagram of the ECS 62 Stereo Expansion module into the ECB 62e Base on page HW Manual-6. The ECS 62 installs by seating the card onto factory installed standoffs on the motherboard.

ECB 62e BASE WITH BOTH STEREO & MONO PORTS

The ECB 62e Base and ECS 62 Stereo Expansion module are shipped with jumpers in the stereo position. Both mono and stereo sources may be used by changing the Mono Jumper blocks as described on page HW Manual-6.

Mono Input signals must be wired to both the Left and Right Inputs of the Base. Both Left and Right Port Outputs produce the same mono signal. See Figure 1 below, and page HW Manual-12 for mono source cable wiring.

Only the bottom ports (Right Channel) are monitored by the Base. Therefore, threshold detection and metering are not operational from the ECS 62.

ECM 82eA MIXERS WITH AEC

Systems may or may not require an AEC. Systems that do require an AEC are those that require teleconferencing. Although most video codec's have an AEC, their AEC typically cannot operate with auto-mixers. It is always best to use the ECM 82eA with a video codec. Systems not requiring an AEC are those that only require speech reinforcement.

There are times you may wish to install multiple ECM 82eA's. These are systems with a group of table microphones where the General or Chairperson sits, and a group of ceiling microphones or a gallery area. For these types of systems you may want to set the table's ECM 82eA to soft suppression and the other ECM 82eA to moderate or strong suppression. For these types of systems connect each MIX OUT of the ECM 82eA to its respective MIX # input on the ECB 62e.

ECM 82e MIXER POST-GATE/PRE-GATE SWITCH

When installing a sound system with zones, it's best to use a Post-Gate mix of the Mics to create a Zone from the AUX Output. This maintains the NOMM level for the Mixer. See Applications - System 4 in the **RaneWare Operators Manual**.

RaneWare note: the AUX Output is not turned On or Off from the Mixer Output control.

This switch is set to **Post-Gate** at the factory. For installations requiring recording, place this switch in the Pre-Gate position. This provides a more natural sounding recording.

This switch is located inside the ECM 82e Mixer. See the diagram on page HW Manual-10.

ECM 82 MIXER PRE-AEC/POST-AEC SWITCH

Under normal circumstances a single AEC is used for the entire system. When using a single AEC with multiple mixers, daisy-chain the ECM 82e Mixers together using MIX OUT to MIX IN. The last mixer in the chain and the one that connects to the MIX 1 input on the ECB 62e must be the ECM 82eA. For this type of configuration the MIX IN switch on the ECM 82eA must be placed in its PRE-AEC position. Rane ships the MIX IN switch on the ECM 82e in PRE-AEC position.

The ECM 82e Mixer is shipped with the MIX IN (on the rear panel) being mixed with the microphones before the Echo Canceller. The *internal* MIX INPUT switch allows the MIX IN to be combined with the microphone signals before the Echo Canceller, thus providing echo cancellation to the microphones of the upstream Mixer. To change to the Mix Input to the pre-Echo Canceller setting, set the internal MIX INPUT switch to the POST-AEC position. See the diagram on page HW Manual-10 to locate the switch.

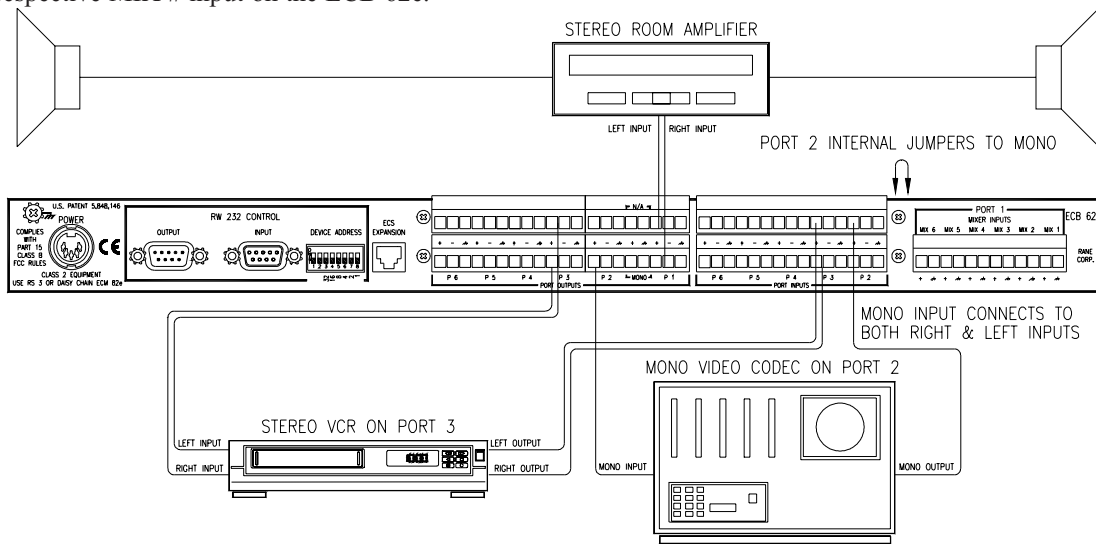

Figure 1. ECB 62e Base with both Stereo and Mono Ports

ECB 62e BASE

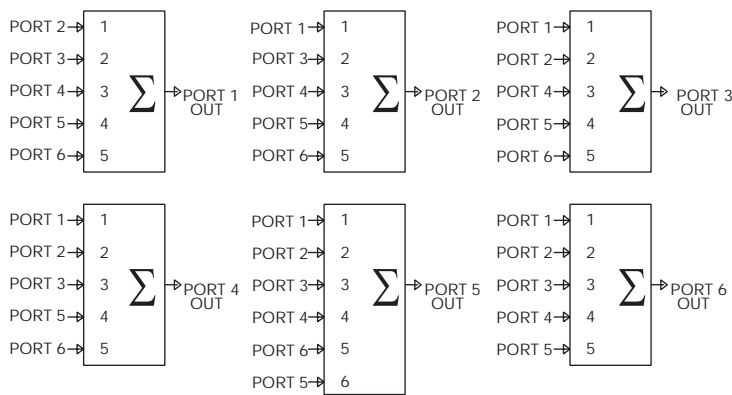

Figure 2. ECB 62e Audio Bridge

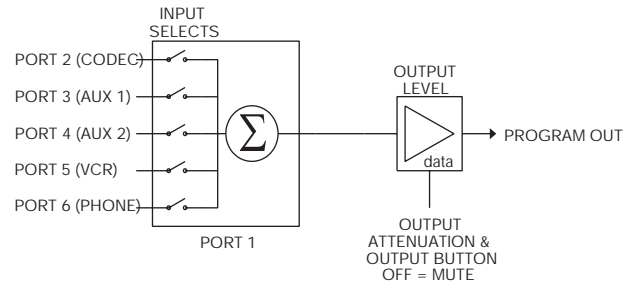

Figure 3. Port 1 Selection and Control

THE BASE

The ECB 62e Base is the master controller of the ECM 82e Mixers. The Base consists of a six port audio bridge, with an optional internal ECS 62 Stereo Expansion module. The Base can be used by itself as a six-by-six Port line-level audio mixer and router. Bridging bases together creates more Ports.

All functionality is controlled through RaneWare. Software controls are printed in bold san-serif type like this. See the **RaneWare Operators Manual** for complete details.

AUDIO BRIDGE

The audio bridge allows the connection of six full-duplex audio devices—thus the term six Port audio bridge. See Figure 2 above. Each Input Port has both a hardware 10 dB PAD switch on the front panel and software programmable Input Attenuation controls. Each Output Port, except Port 5, consists of a program selectable five input Audio Mixer/Router and programmable Output Attenuation controls, as shown in Figure 3. Port 5 has a program selectable six input Audio Mixer/Router. *This type of configuration for Ports 1-4 and 6 prevents the connection of an Input to its Output, avoiding a possible feedback condition.*

PORT 1

The Port 1 Input is different from all other Ports. This Port contains a six input line summer, connecting up to six Mixers. All mics in the room are connected to this Port through the ECM 82e Mixers. This Port contains a six input line mixer, connecting up to six ECM 82e Mixers. See Figure 3.

The Output of Port 1 is also different from all other Ports. It is designated as the *Program Port*, delivering audio to the room sound system. It has both a balanced Right channel and a summed Mono Output of Right and Left. An installed ECS 62 Stereo Expansion Module delivers the balanced Left channel. The Mono Output connects to the Echo Canceller Reference on all ECM 82e Mixers.

STATUS SIGNALS

The top center of the ECS software screen (and the ECB 62e front panel) contains the following Status indicators – all of which can be obtained via RS-232 based room control devices. (In the ECB 62e Device Control Language of the

RaneWare Operators Manual-29 refer to the RW 232 Command Get OPSTAT.)

The three Signal indicators – Program, Port and Mic – are used within ECS to identify the current audio state of the system, i.e., where audio is present or absent. The patented performance advantages and much of ECS’s automatic functionality is derived from the system being aware of these indicators’ current state.

Program Signal indicator (PGS LED on the ECB 62e)

The Program indicator lights whenever audio is detected at the Port 1 (Program) Output, thus indicating that audio should be heard in the room. (If P3 Prog Contribute on the System tab is checked, both Port 1 and Port 3 Outputs are used to “sense” Program audio.

Port Signal indicator (PTS LED on the ECB 62e)

The Port indicator lights whenever audio is detected at any Port Input whose Signal Mode is set to Automatic. This includes mixer audio entering Port 1.

Mic Signal indicator (MCS LED on the ECB 62e)

This lights whenever audio is detected at any Active Mic whose Mic Mode is set to Automatic.

Advanced auto power down example: Use the room controller to monitor the Port and Mic Signal indicators.

When either is present, reset the power down timer that eventually shuts down the system thus saving the projector bulb, the associated power bill and actually save money!

Master Port

Identifies the current Master PORT, which is the Port that most recently detected audio. Use Master Port Delay on the System tab for multipoint video applications.

Master Mic

Identifies the current Master Mic, which is the Mic that most recently detected audio. A Master Mic is a status signal generated when audio is detected at a Mic Input for a period of time longer than the Master Mic Delay timer setting. If an Input is assigned as Last On, and audio is detected for a period longer than the Master Mic Delay timer, that Input becomes the Master and remains on until a new Input takes over. The old Master Mic then releases and returns to its set Gate Depth. Use Master Mic Delay on the System tab for video-follows-audio applications.

ECB 62e Base - Front Panel Description

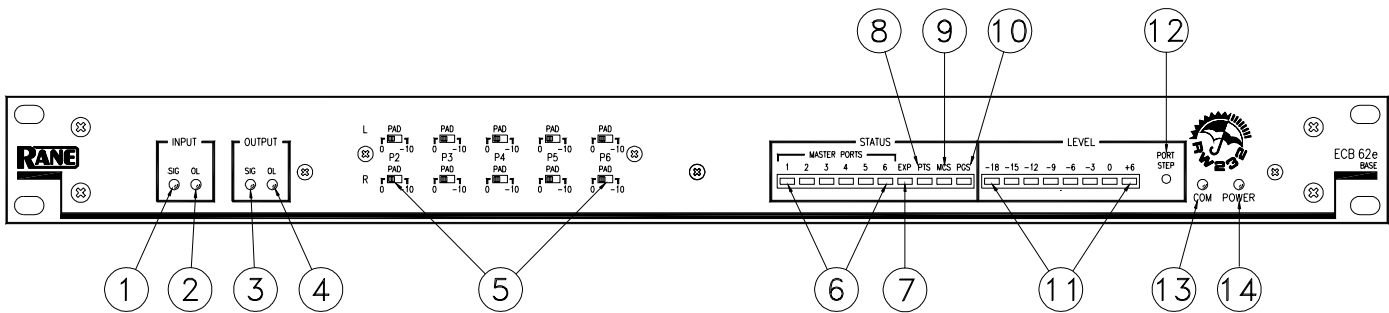

- ① **INPUT SIG level indicator:** Lights when the Input signal on any Port, before trim, is above -25 dBu. Use this to check signal flow.
- ② **INPUT OL level indicator:** Lights when the Input signal on any Port, before trim, is within 2 dB of clipping.
- ③ **OUTPUT SIG level indicator:** Lights when the Output signal on any Port is above -25 dBu. Use this to check signal flow.
- ④ **OUTPUT OL level indicator:** Lights when the Output signal on any Port is above 6 dBu.
- ⑤ **INPUT PADS:** Ports 2 through 6 have switch selectable 0 or -10 dB attenuation. Use -10 dB for pro audio devices with 0 dBu or greater output levels.
- ⑥ **SYSTEM STATUS INDICATOR—MASTER PORTS:** Displays the current Master Port. It is also used by the PORT STEP button (see ⑫) to display the current Port monitored by the LEVEL Meter.
- ⑦ **EXP status indicator:** EXPansion port data - Lights when receiving data from the ECM 82e Mixers.
- ⑧ **PTS status indicator:** PorT Signal - Lights when audio is detected at any Port.
- ⑨ **MCS status indicator:** MiC Signal - Lights when audio is detected at any Mic Input from any ECM 82e Mixer.
- ⑩ **PGS status indicator:** ProGram Signal - Lights when audio is detected at any Port Output.
- ⑪ **LEVEL:** VU meter Selectively displays all Port Inputs and Port 1 and 3 Outputs by using the PORT STEP (see ⑫). This is also an error display:
 - 3 by itself indicates an RW 232 receive parity error.
 - 0 by itself indicates an Expansion Network overflow.
 - +6 by itself indicates an RW 232 overflow. During power-up initialization, this flashes until the system is ready. If this keeps flashing longer than 10 seconds, RAM may be damaged. The ECB 62e needs servicing. If this illuminates steadily, the system has overflowed. To remedy, cycle the power off, then back on.
- ⑫ **PORT STEP button:** Pressing this for 1 second causes the MASTER PORT STATUS LED to flash the currently monitored port for the LEVEL meter. If this button is pressed and held for 5 seconds, the monitored Port can be incremented by pressing the button in 1 second steps. The MASTER PORT STATUS LEDs will step Port 1 thru Port 6 Inputs (LED 1-6), then back for the Port 1 Output (LED 1), then the Port 3 Output (LED 3), and then returning back to Port 1's Input (LED 1).
- ⑬ **COM indicator:** flashes randomly when receiving valid data from the control system or PC. *If the DEVICE ADDRESS is not within a valid range (1-250), this LED flashes steadily at ½ second intervals.*
- ⑭ **POWER indicator:** Lights when the Base's operating system is running.

ECB 62e Base - Rear Panel Description

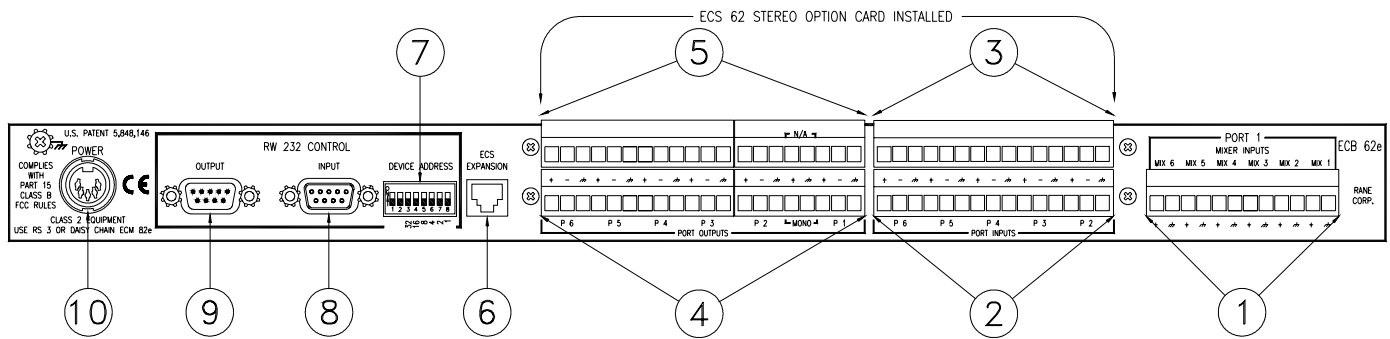

- ① **PORT 1 MIXER INPUTS:** MIX 1 thru MIX 6 connect to the MIX OUTs of the ECM 82e Mixers via the 12-pin Euroblock.
- ② **PORT INPUTS:** P2 thru P6 connect to balanced line sources via this 15-pin Euroblock. When the ECS 62 Stereo Option card is installed, these are the *Right* channel Inputs. See page HW Manual-6.
- ③ **ECS 62 PORT INPUTS:** Connects the *Left* channel Inputs. See page HW Manual-6.
- ④ **PORT OUTPUTS:** This 8-pin Euroblock provides P1, P1 MONO and P2 Outputs, and the 12-pin Euroblock provides P3 thru P6. (P1 MONO is used for the ECM 82e Echo Canceller Reference.) When the ECS 62 Stereo Option card is installed, these are the *Right* channel Outputs.
- ⑤ **ECS 62 PORT OUTPUTS:** Connect the *Left* channel P1 and P2 Outputs from the 8-pin Euroblock, while P3 thru P6 are delivered from the 12-pin Euroblock. (P1 Mono Not Applicable—available at ④.)
- ⑥ **ECS EXPANSION port:** This RJ12 mod jack and cable (included) is an Expansion data interface to control and communicate with the ECM 82e Mixers. *This proprietary high speed data interface cannot be used with non-ECS products.* During power-up of the Base, all connected Mixers are polled, then sent their respective data, from the Base's non-volatile memory. The Base then polls the Mixers at one minute intervals checking for dropped or added mixers. If found, the Base resets.
- ⑦ **RW 232 CONTROL - DEVICE ADDRESS:** Sets the RW 232 address for the ECB 62e. Each RW 232 unit requires a different address. If the RW 232 Control Device Address is set to an invalid address, the COM LED continually flashes. *The Device Address can be changed without power cycling the unit.* See page HW Manual-13.
- ⑧ **RW 232 CONTROL - INPUT:** This DB-9 female connects to the RS-232 output of the controller (or PC), or the OUTPUT of another RW 232 unit connected to the controller. Rane uses a standard RS-232 interface using Rane's RW 232 protocol operating at 19.2 kb. Units connect by daisy-chaining the products on a serial bus, OUTPUT to INPUT.
- ⑨ **RW 232 CONTROL - OUTPUT:** This DB-9 male connects to downstream RW 232 units.
- ⑩ **POWER input jack:** This 5-pin DIN connects to the included RS 3 power supply, or daisy-chained with the Power Loop cable from the ECM 82e connected to the RS 3 power supply. **Warning! Connect the power supply DIN connector to the Base BEFORE connecting to AC power, otherwise damage may occur.** See page HW Manual-11. A maximum of 3 units may be daisy chained off of one RS 3 power supply (1 ECB 62e Base and 2 ECM82e Mixers or 3 ECM 82e Mixers).

ECB 62e Installation Notes

If an **ECS 62 Stereo card** is to be installed in the ECB 62e, install the required mono jumper on the ECB 62e motherboard before installing the ECS 62 (see page HW Manual-6).

The **ECS Expansion port** is the control between the ECB 62e and the ECM 82e's. Using the supplied RJ12 cable connect the ECM 82es to the ECB 62e. Note: The ECM 82e's do not use RW 232 addressing. The ECS address for the ECM 82es determines the Mic number on the ECM 82e. ECS address 1 is Mixer 1, Mics 1 thru 8. ECS address 6 is Mixer 6, Mics 41 thru 48. Only use termination on the last Mixer when using four or more Mixers. ECS termination is located inside the ECM 82e.

ECS 62 STEREO EXPANSION MODULE

DESCRIPTION

The ECS 62 is a plug-in module for the ECB 62e Base. Once installed, the Base can accommodate both stereo and mono audio. Included on the module is a duplicate of the Base's Audio Bridge, with the exception that Port 1 has no external input connection, and the Mono Program Output is eliminated. The stereo module mounts on top of the ECB 62e motherboard and is designated as the Left channel.

The ECS 62 installs by temporarily removing the top cover of the ECB 62e and seating the card onto factory installed standoffs on the motherboard. See Figure 8 below.

Warning: Proper static discharge measures must be followed when installing or configuring this card.

ECS 62 LEFT CHANNEL FEATURES

- Six Port Selective Audio Bridge, control is combined with the ECB 62e Right channel Audio Bridge.
- Hardware Pad switches set Input attenuation on Ports 2-6.
- Software Programmable Level controls on all Inputs and Outputs combined with the Base's Right channel Levels.
- Port 1's mono inputs deliver signal to both Right and Left channels of Port 1.
- Internal hardware jumpers provide mono Outputs.

STEREO & MONO OPERATION

Both mono and stereo equipment are accommodated by installing the ECS 62 into the ECB 62e and placing the internal Mono Output jumpers to their "mono" positions for mono equipment. Mono Input signals must be wired to both the Left and Right Inputs of the Base. Both Left and Right Port Outputs produce the same mono signal. See page Manual-12 for mono source cable wiring.

Since Port 1 is designated as the Program Output, it does not have a Mono jumper. Both mono and stereo Outputs are provided simultaneously from Port 1.

Note: Audio levels from the ECS 62 are not monitored by the ECB 62e Base.

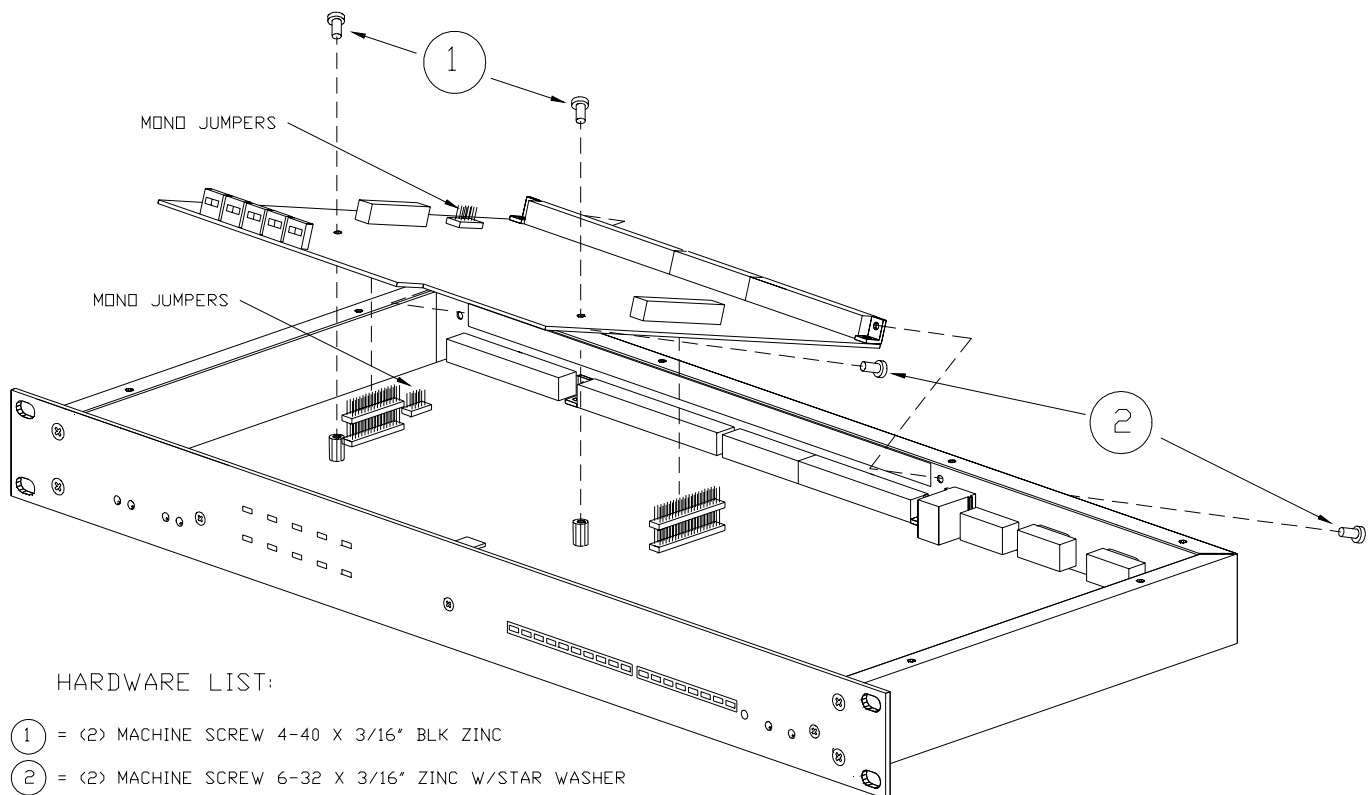

Figure 7. ECS 62 Stereo Expansion Card installation with Mono Jumper locations

ECM 82e MIXER

The ECM 82e Mixer is a digitally-controlled-analog 8- channel Mic/Line auto-mixer. An optional internal DSP Echo Canceller module is available either separately (model ECA 2) or included (model ECM 82eA). Each Base supports up to 6 Mixers, allowing 48 Inputs. All system parameters of the Base and Mixers are stored within the Base using non-volatile memory (no batteries). *The ECM 82e Mixer is not a stand-alone device and will not operate without a Base connected.*

All functionality is controlled through RaneWare. Software controls are printed in this manual in san-serif type like this. See the **RaneWare Operators Manual** for details.

LAST-ON or GATED MODES

Unique among automatic mic mixers, each Mic can be independently set to Last On or Gated. A Mic assigned as Gated simply opens the mic when the input signal is above the Threshold Level, and returns to its Gate Depth when the signal drops below the Threshold Level and the Release Timer has expired. A Mic assigned as Last On remains on once it becomes the Master Mic.

This is useful in boardrooms where the head table would require last-on mics and the audience area requires gated mics. This way, the board members (and their background noise) are always heard, while the less-often used audience (i.e., questions) mics, gate off when not in use. Rane has patented this concept – the marketing buzz word being *Smart Last On™*. Having an open mic also maintains the full duplex awareness of the conference.

MZEC™ (em-zeck)

Using large auto mixers with an echo canceller can cause echo problems when several microphones gate-on at the same time. If a single Echo Canceller is adapting to all Mic signals, and more than three Mics are on at the same time, the acoustic model for the room may become too complex. This causes Echo Canceller divergence, resulting in more suppression or return echo. To eliminate this problem, each ECM 82e Mixer allows the addition of an internal Acoustic Echo Canceller. Placing an Echo Canceller in each mixer reduces the number of acoustical echo paths for a multi-microphone system, improving the system audio quality. (See the **ECA 2 Acoustic Echo Canceller** module on page HW Manual-10.) This method is called *MultiZone Echo Cancelling (MZEC™)*.

Important: *The ECB 62e PORT 1 MONO OUTPUT must be connected to all the E/C REF Inputs of the ECM 82e Mixers.*

QuickAdapt™

The QuickAdapt algorithm allows a single AEC to operate the entire system. This algorithm uses the Rane exclusive Smart Last On™ feature to precondition the AEC for a microphone gate change. This feature can be disabled by setting a Mic Gate Depth to 0 dB on the ECM 82eA. If you want to maintain the QuickAdapt algorithm, but you also want to keep a microphone opened, set the Mic Gate Depth to -1 dB. Another QuickAdapt feature is to precondition the AEC for a microphone mute condition. This allows standard Push-To-Talk microphones to be used.

PHANTOM POWER

The ECM 82e Mixer is *shipped with the Phantom Power switches in the “on” position*. To change, locate the Phantom Power switches on the rear panel of the unit and select the “off” position when you don't want phantom power.

The ECM 82e Mixer is *shipped with an internal switch selecting 24v Phantom Power*. 12v Phantom power may be selected by changing the internal switch from 24v to 12v. See the diagram on page HW Manual-10 to locate the switch.

REDUCING NOISE AND ACOUSTIC GAIN

To reduce noise and acoustic gain due to the mixing of multiple microphones, the ECM 82e uses a special NOMM Mode (Number Of Mics per Mixers open). This function maintains full level at the loudest Mic Input while reducing Gains of the other Mics in order to keep unity gain. Turning on this feature also enables a limiter for each Mic channel.

DEVICE ADDRESS

The Mixer's rear panel ECS INTERFACE DEVICE ADDRESS determines its Mixer number and Mic Input numbers. For example, Device Address 1 is Mixer 1 including Mics 1-8, and Device Address 2 is Mixer 2 including Mics 9-16. Only Device Addresses 1 through 6 are allowed, since this is the maximum Mixers per Base. When a Mixer is first powered up and has not received data from the Base, the Mic Status LEDs display the Mixer Device Address.

An invalid Device Address set on the Mixer causes its COM LED to continually flash. The ECM 82e's power must be cycled after changing the Device Address. ***Unplug from the wall, not the unit!***

ECM 82e Mixer - Front Panel Description

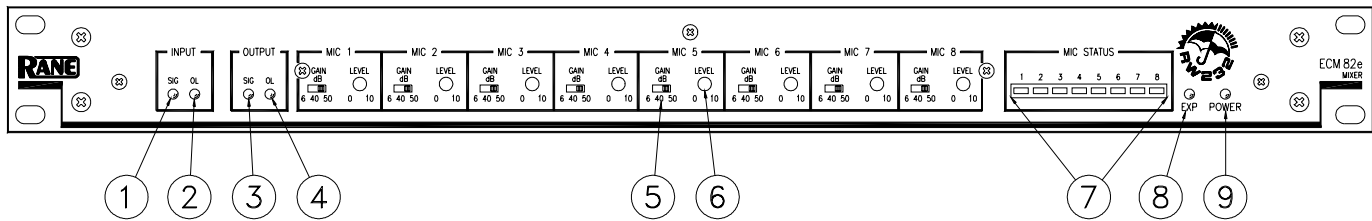

- ① **INPUT SIG indicator:** Lights when any Input signal, before trim, is above -25 dBu. Use to check signal flow.
- ② **INPUT OL indicator:** Lights when the Input signal on any Input, before trim, is within 2 dBu of clipping. Watch this when Selecting the Input GAIN and setting the LEVEL.
- ③ **OUTPUT SIG indicator:** Lights when the Mix Output signal is above -25 dBu. Use to check signal flow.
- ④ **OUTPUT OL indicator:** Lights when the Mix Output signal level is 2 dBu before clipping.
- ⑤ **MIC GAIN switch:** Selects between +6 dB (line level), +40 dB (most mics), or +56 dB.
- ⑥ **MIC LEVEL trim:** Use a small flat screwdriver to adjust the Level from *off* to full *on*.
- ⑦ **MIC STATUS indicators:** Displays the status of the Mic gate: A *flashing* LED indicates the Mic is Gated On, or the Mic is the Master Mic for this Mixer. A *continuous* LED indicates the Mic is the system's Master Mic. When power is first applied, the ECM 82e displays its DEVICE ADDRESS until it receives data from the ECB 62e. Once data is received, the ECM 82e lights LEDs 1, 2, and 6 for about 1 second.
- ⑧ **EXP indicator:** Lights when receiving Expansion Data.
- ⑨ **POWER indicator:** Lights when the processor is operating properly.

ECM 82e Installation Notes

If Phantom Power is not required remove the top cover to the ECM 82e and disable it. See page HW Manual-10.

Always leave the RS 3 power supplies for last. Once all the wiring is completed, connect the loop thru power cables between the ECM 82es ending at the ECB 62e. Before connecting the RS 3 make certain that it is not connected to the AC power. See page HW Manual-11.

The **ECS Expansion port** is the control between the ECB 62e and the ECM 82es. Using the supplied RJ12 cable connect the ECM 82es to the ECB 62e. Note: The ECM 82es do not use RW 232 addressing. The ECS address for the ECM 82es determines the Mic number on the ECM 82e. ECS address 1 is Mixer 1, Mics 1 thru 8. ECS address 6 is Mixer 6, Mics 41 thru 48.

ECM 82e Mixer - Rear Panel Description

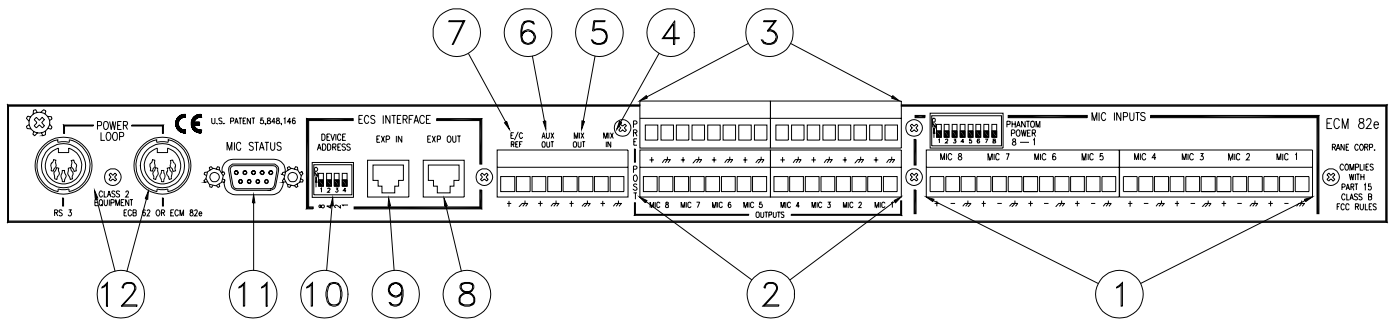

- ① **MIC INPUTS:** These balanced Inputs connect MIC 1-MIC 4 on one 12-pin Euroblock, and MIC 5-MIC 8 on another 12-pin Euroblock. See page HW Manual-12 for cable wiring.
- ② **POST-GATE OUTPUTS:** One 8-pin Euroblock delivers MIC 1-MIC 4; the other 8-pin Euroblock delivers MIC 5-MIC 8.
- ③ **PRE-GATE OUTPUTS:** One 8-pin Euroblock delivers MIC 1-MIC 4; the other 8-pin Euroblock delivers MIC 5-MIC 8.
- ④ **MIX IN:** This input can be mixed as either PRE-AEC or POST-AEC. For single AEC applications use the PRE-AEC setting (factory default), (see figure 11, next page).
- ⑤ **MIX OUT:** This Post-Gate Output is program Selectable as either a Pre-Echo-Canceller or Post-Echo-Canceller, and is typically connected to one of the MIX INPUTS on the ECB 62e Base. *For Pre-Echo Cancellation, Select Bypass in the Echo Canceller box on the Mixer’s page in RaneWare.*
- ⑥ **AUX OUT:** This Output is switch selectable as either a Post-Gate or Pre-Gate before the Echo Canceller. This switch is set to “Post-Gate” at the factory. If required, remove the top cover and look for the switch marked “S1” in the middle toward the back of the circuit board. Set the switch according to the silkscreen and replace the cover and screws.
- ⑦ **E/C REF:** Echo Canceller Reference—This Input typically connects to the Port 1 MONO Output of the ECB 62e Base when an ECA 2 Echo Canceller is used within this Mixer. The average signal level at this input must be between -10 and 0 dBu.
- ⑧ **ECS INTERFACE—EXP OUT:** This RJ12 mod jack (and supplied cable) sends Expansion data, connecting to the EXP IN jacks on subsequent ECM 82e Mixers.
- ⑨ **ECS INTERFACE—EXP IN:** This RJ12 mod jack (and supplied cable) receives Expansion data, connecting to the ECS EXPANSION jack on the ECB 62e Base or the EXP OUT jacks on upstream ECM 82e Mixers.
- ⑩ **ECS INTERFACE—DEVICE ADDRESS:** Selects the Mixer number 1 thru 6. The Device Address is set using a binary code determined using the following table. For example, turning ON the switches labeled ‘1’ and ‘2’ on the chassis yields address ‘3’. In the following table, 0 means switch *down* (OFF), 1 means switch *up* (ON).

	SWITCH #s	1234
	1	0001
	2	0010
DEVICE	3	0011
ADDRESS	4	0100
	5	0101
	6	0110
SILKSCREEN #s		8421

An invalid Device Address set on the Mixer causes its COM LED to continually flash. The ECM 82e’s power must be cycled after changing the Device Address. ***Unplug from the wall, not the unit!***

- ⑪ **MIC STATUS:** This DB-9 female jack is an *open collector Output* reflecting the current Master or Gated Mic. A new Master or Gated Mic causes its corresponding pin to go low for 50 milliseconds. Pin 1 is Mic 1, pin 2 is Mic 2, pin 3 is Mic 3... and pin 9 is ground. This connector can provide status information for video-follows-audio.
- ⑫ **POWER LOOP:** A DIN cable (included) connects up to three ECM 82 Mixers and one ECB 62e Base, powered from one RS 3 Power Supply. Connect only a Rane RS 3 power supply to either of these DIN jacks or an attached unit with an RS 3. **Do not connect two RS 3 units to the same unit or loop. Warning! Connect the DIN power supply connectors to the units before connecting to AC power, otherwise damage may occur.** See POWER on page HW Manual-11. A maximum of 3 units may be daisy chained off of one RS 3 power supply (1 ECB 62e Base and 2 ECM82e Mixers or 3 ECM 82e Mixers).

ECA 2 ECHO CANCELLER MODULE

DESCRIPTION

The ECA 2 is a continually adaptive Acoustic Echo Canceller module for the ECM 82e Mixer using the Rane QuickAdapt™ algorithm. The ECM 82eA Mixer is shipped with the ECA 2 installed. The QuickAdapt algorithm allows a single AEC to operate the entire system. This algorithm uses the Rane exclusive Smart Last On™ feature to precondition the AEC for a microphone gate change. This feature can be disabled by setting a Mic Gate Depth to 0 dB on the ECM 82eA. If you want to maintain the QuickAdapt algorithm, but you also want to keep a microphone opened, set the Mic Gate Depth to -1 dB. Another QuickAdapt feature is to precondition the AEC for a microphone mute condition. This allows standard Push-To-Talk microphones to be used. When using the single AEC method, daisy-chain the Mixers by connecting MIX OUT to MIX IN on the with the last connection before the ECB 62e being the ECM 82eA. Only the ECM 82eA requires its AEC Reference input to be connected.

Multiple ECM 82eA mixers can also be used in situations where areas in the room are different. For example, table microphones may only require soft suppression, while ceiling microphones may require moderate or strong suppression. This method of echo cancelling is called MZEC™ MultiZone Echo Cancelling. When using multiple ECM 82eA mixers, connect the MIX OUT of each mixer to its respective MIX # input on the ECB 62e.

Since the Echo Canceller automatically adapts to the room, training is not required.

To upgrade an ECM 82e to an ECM 82eA install the ECA 2 by temporarily removing the top cover of the ECM 82e and seating the module onto factory installed standoffs on the motherboard. After installing the Echo Canceller, disable Echo Canceller Bypass in RaneWare (see the RaneWare Operators Manual).

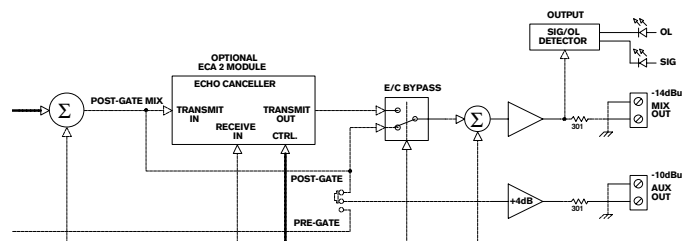

Figure 10. ECA 2 Block Diagram (detail from Data Sheet Block Diagram).

Warning: Proper static discharge measures must be followed when installing or configuring this card.

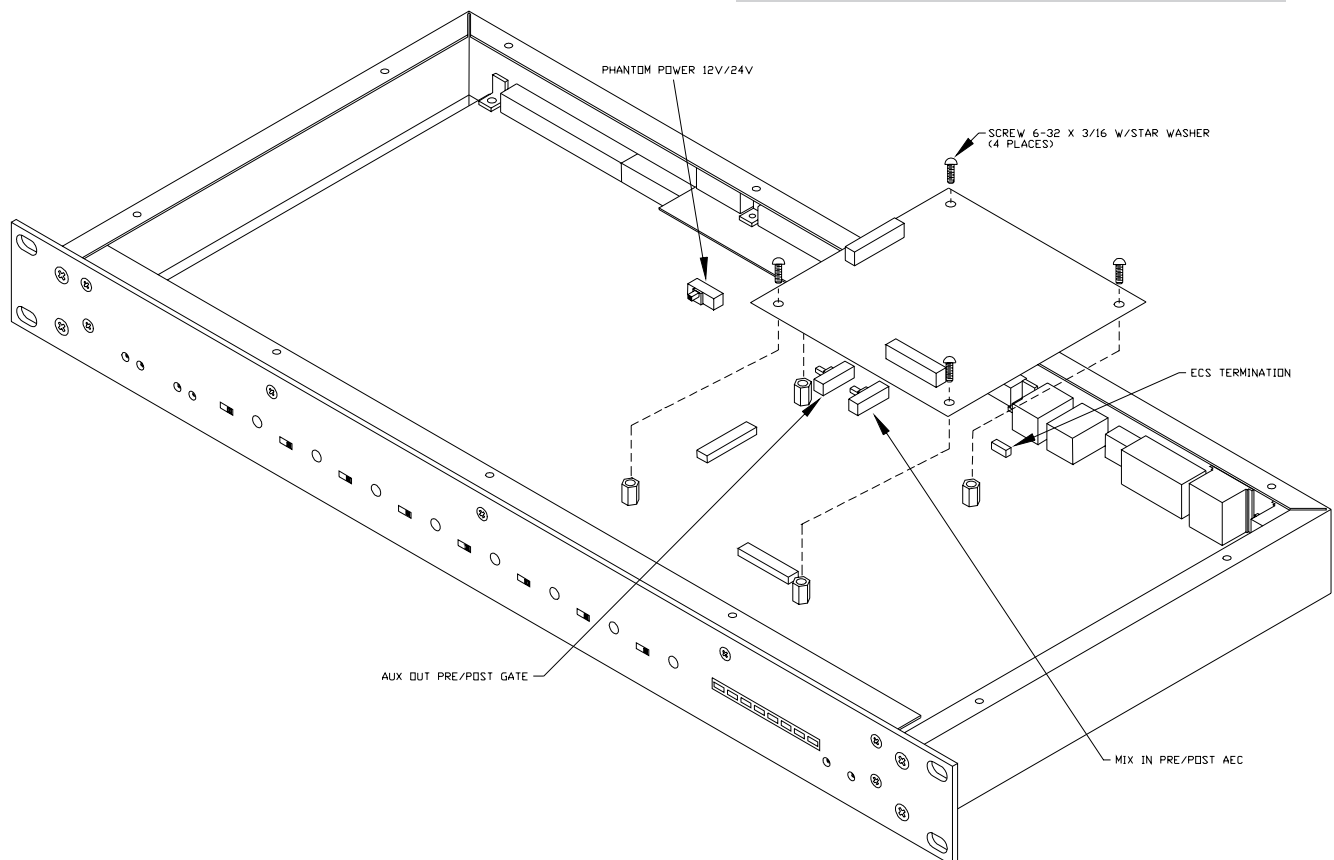

Figure 11. ECA 2 Installation with ECM 82e Phantom Power and network termination jumper locations

POWER, AUDIO, & DATA CONNECTIONS

POWER

The Rane RS 3 Power Supply is provided with each ECB 62e Base, and required for operation of the ECM 82e Mixer. Daisychaining is possible with the DIN cables (included with the ECM 82e). One RS 3 will power any *one* of the following:

- (1) Base and (2) Mixers
- (3) Mixers

When connecting the ECS units to other components in your system for the first time, *leave the power supplies for last, and then connect the DIN power cable to the unit BEFORE connecting AC power.* This gives you a chance to correct any mistakes before any damage is done to your units, speakers, computer, ears, etc.

AUDIO

ECS units have both balanced and unbalanced Inputs and Outputs, with chassis-grounded shields. Chassis ground is to be connected to a known earth ground. Refer to Figure 13 on the following page.

DATA

To control the units from a computer, use nine-pin RS-232 cables 50 feet or shorter. *The cable must not be a null-modem type.* A short cable is supplied for connecting adjacent units. Daisychain up to 16 units by connecting the COM port on the computer to the INPUT connector on the first unit, and the OUTPUT connector of each unit to the next unit's INPUT. Since RS-232 can pass through RW 232, additional RS-232 devices may be attached at the end of the RW 232 chain. See the pin-outs in Figure 13 on the following page.

DETAILS

Large racks of equipment such as ECS may generate excess heat, requiring extra space between units, and/or forced air ventilation to reduce the ambient temperature in the rack.

Before powering the units, set the DEVICE ADDRESS switches as shown on page HW Manual-13.

OK, now for the AC line cord.

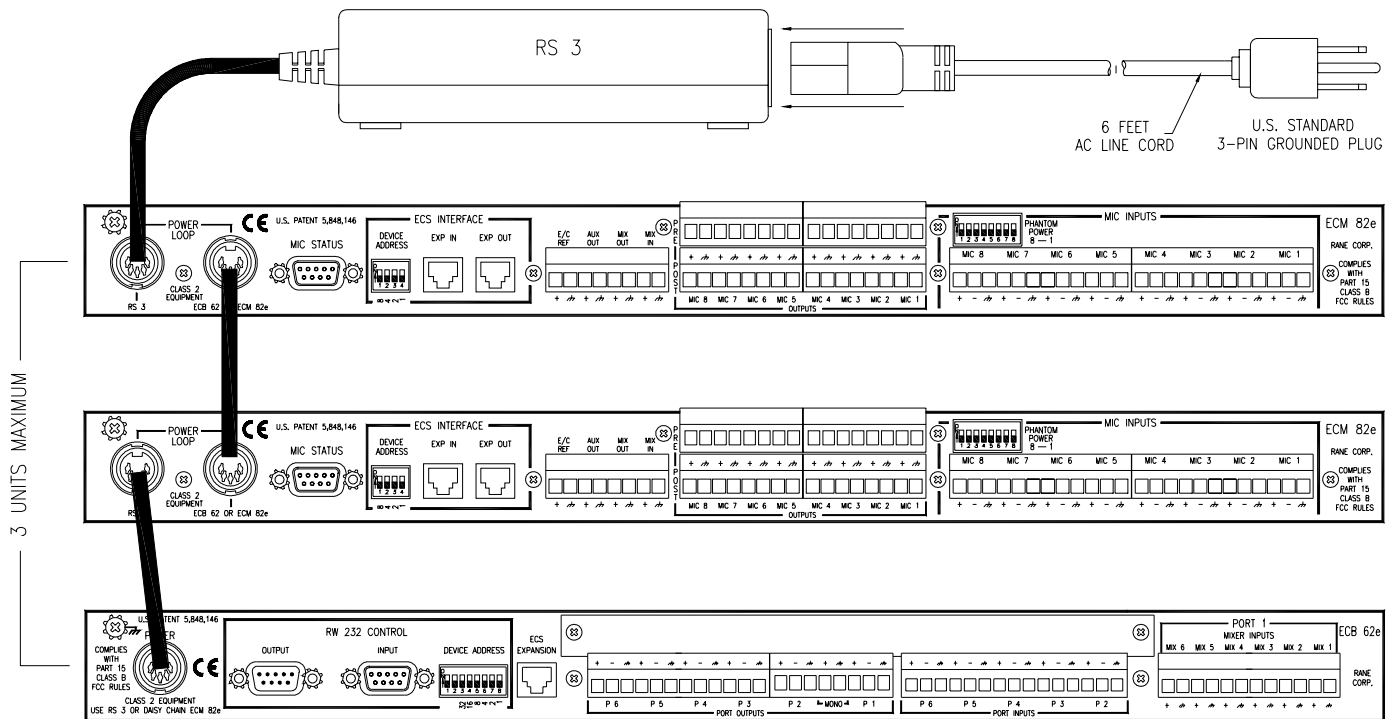

Figure 12. RS 3 daisychained power connections

FROM OUTPUT

TO INPUT



Unbalanced source to balanced ECB 62e Input, 2-conductor cable with shield



Unbalanced source to balanced ECB 62e Input, 1-conductor cable with shield

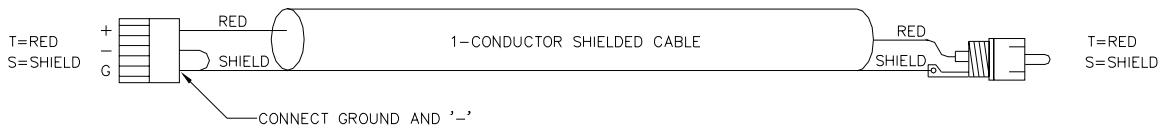

Balanced ECB 62e Output to an unbalanced unit

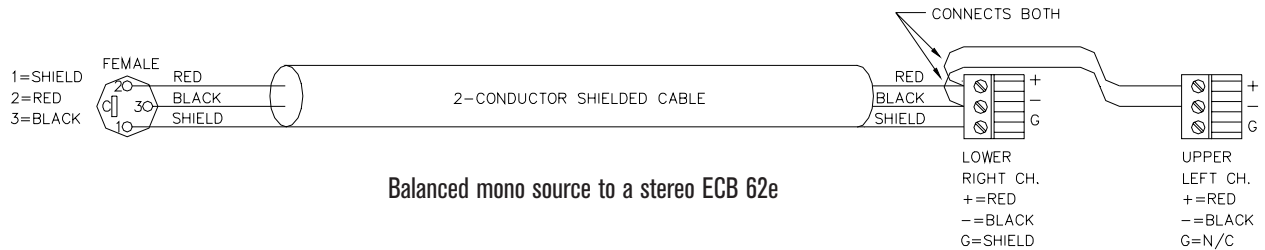

Balanced mono source to a stereo ECB 62e

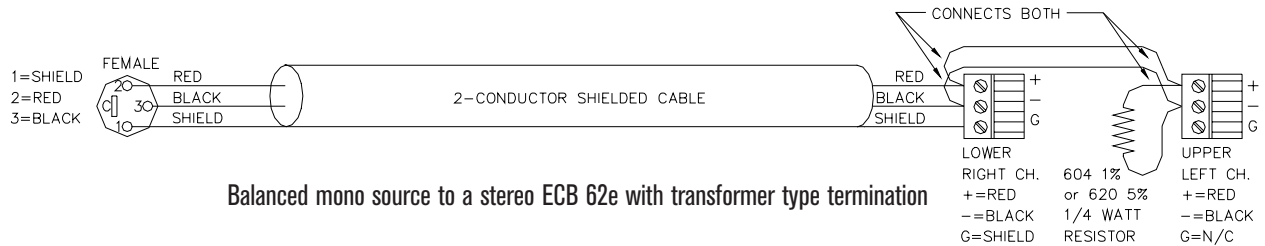

Balanced mono source to a stereo ECB 62e with transformer type termination

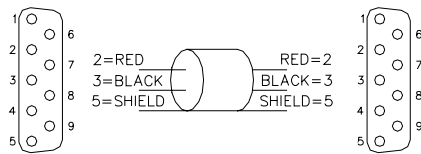

PC to ECB 62e - DB-9 female to DB-9 male

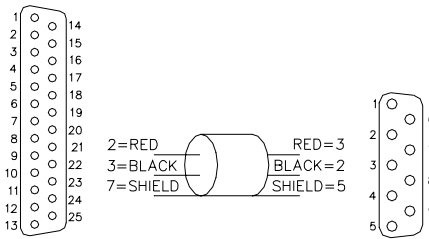

PC to ECB 62e - DB-25 female to DB-9 male

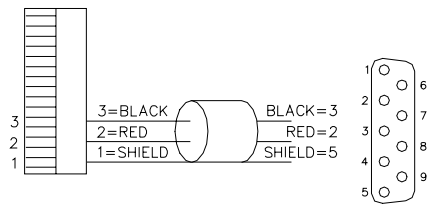

AMX AX 232 to ECB 62e - Euroblock to DB-9 male

Figure 13. ECS cable wiring

SETTING THE DEVICE ADDRESS

The Device Address is set using a binary code which may be determined using the following table, our Windows Address Calculator program, or by adding the place values (1-128) silkscreened on the chassis. *Ignore all numbers printed directly on the switch.* For example, turning ON the switches labeled '1' and '2' yields address '3'. In the following table, 0 means switch *down* (OFF), 1 means switch *up* (ON), and the left-most digit corresponds to the switch labeled '128'.

Rane also provides a special calculator to assist in setting the dip switches. After installing the software, in the RaneWare program group, launch the RaneWare 232 Address Calculator. This binary calculator converts decimal numbers into corresponding dipswitch settings.

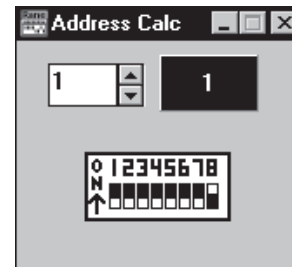

Figure 14. Device Address Calculator

1	00000001	50	00110010	100	01100100	150	10010110	200	11001000
2	00000010	51	00110011	101	01100101	151	10010111	201	11001001
3	00000011	52	00110100	102	01100110	152	10011000	202	11001010
4	00000100	53	00110101	103	01100111	153	10011001	203	11001011
5	00000101	54	00110110	104	01101000	154	10011010	204	11001100
6	00000110	55	00110111	105	01101001	155	10011011	205	11001101
7	00000111	56	00111000	106	01101010	156	10011100	206	11001110
8	00001000	57	00111001	107	01101011	157	10011101	207	11001111
9	00001001	58	00111010	108	01101100	158	10011110	208	11010000
10	00001010	59	00111011	109	01101101	159	10011111	209	11010001
11	00001011	60	00111100	110	01101110	160	10100000	210	11010010
12	00001100	61	00111101	111	01101111	161	10100001	211	11010011
13	00001101	62	00111110	112	01110000	162	10100010	212	11010100
14	00001110	63	00111111	113	01110001	163	10100011	213	11010101
15	00001111	64	01000000	114	01110010	164	10100100	214	11010110
16	00010000	65	01000001	115	01110011	165	10100101	215	11010111
17	00010001	66	01000010	116	01110100	166	10100110	216	11011000
18	00010010	67	01000011	117	01110101	167	10100111	217	11011001
19	00010011	68	01000100	118	01110110	168	10101000	218	11011010
20	00010100	69	01000101	119	01110111	169	10101001	219	11011011
21	00010101	70	01000110	120	01111000	170	10101010	220	11011100
22	00010110	71	01000111	121	01111001	171	10101011	221	11011101
23	00010111	72	01001000	122	01111010	172	10101100	222	11011110
24	00011000	73	01001001	123	01111011	173	10101101	223	11011111
25	00011001	74	01001010	124	01111100	174	10101110	224	11100000
26	00011010	75	01001011	125	01111101	175	10101111	225	11100001
27	00011011	76	01001100	126	01111110	176	10110000	226	11100010
28	00011100	77	01001101	127	01111111	177	10110001	227	11100011
29	00011101	78	01001110	128	10000000	178	10110010	228	11100100
30	00011110	79	01001111	129	10000001	179	10110011	229	11100101
31	00011111	80	01010000	130	10000010	180	10110100	230	11100110
32	00100000	81	01010001	131	10000011	181	10110101	231	11100111
33	00100001	82	01010010	132	10000100	182	10110110	232	11101000
34	00100010	83	01010011	133	10000101	183	10110111	233	11101001
35	00100011	84	01010100	134	10000110	184	10111000	234	11101010
36	00100100	85	01010101	135	10000111	185	10111001	235	11101011
37	00100101	86	01010110	136	10001000	186	10111010	236	11101100
38	00100110	87	01010111	137	10001001	187	10111011	237	11101101
39	00100111	88	01011000	138	10001010	188	10111100	238	11101110
40	00101000	89	01011001	139	10001011	189	10111101	239	11101111
41	00101001	90	01011010	140	10001100	190	10111110	240	11110000
42	00101010	91	01011011	141	10001101	191	10111111	241	11110001
43	00101011	92	01011100	142	10001110	192	11000000	242	11110010
44	00101100	93	01011101	143	10001111	193	11000001	243	11110011
45	00101101	94	01011110	144	10010000	194	11000010	244	11110100
46	00101110	95	01011111	145	10010001	195	11000011	245	11110101
47	00101111	96	01100000	146	10010010	196	11000100	246	11110110
48	00110000	97	01100001	147	10010011	197	11000101	247	11110111
49	00110001	98	01100010	148	10010100	198	11000110	248	11111000
		99	01100011	149	10010101	199	11000111	249	11111001
								250	11111010

FCC NOTICE

This equipment has been tested and found to comply with the limits for a Class B digital device, pursuant to Part 15 of the FCC Rules. These limits are designed to provide reasonable protection against harmful interference when the equipment is operated in a residential installation. This equipment generates, uses, and can radiate radio frequency energy and, if not installed and used in accordance with the instructions, may cause harmful interference to radio communications. However, there is no guarantee that interference will not occur in a particular installation. If this equipment does cause harmful interference to radio or television reception, which can be determined by turning the equipment off and on, the user is encouraged to try to correct the interference by one or more of the following:

1. Re-orient or relocate the receiving antenna.
2. Increase the separation between the equipment and the receiver.
3. Connect the equipment into an outlet on a circuit different from that to which the receiver is connected.
4. Consult the dealer or an experienced radio/TV technician.

CANADIAN EMC NOTICE

This Class B digital apparatus meets all requirements of the Canadian Interference-Causing Equipment Regulations.

Cet Appariel numerique de la classe B respecte toutes les exigences du Reglement sur le material brouilleur du Canada.

CHASSIS GROUNDING

If after hooking up your system it exhibits excessive hum or buzzing, there is an incompatibility in the grounding configuration between units. Here are some things to try:

1. Try combinations of lifting grounds on units supplied with ground lift switches (or links).
2. Verify all chassis are tied to a good earth ground.
3. Some units with outboard power supplies do *not* ground the chassis through the line cord. Make sure these units are solidly grounded by tying the Chassis Ground Point to known earth ground. Use a star washer to guarantee proper contact.