

General Description

The Rane DA 216a Distribution Amplifier is a two-input, sixteen-output splitter/distribution amplifier. The DA 216a is capable of providing sixteen discrete balanced outputs from one or two balanced mic-level or line-level inputs. The level of each output is individually adjusted via one of the sixteen screwdriver Output Level controls on the front panel. *Each output may be assigned to either or both inputs via front panel accessible slide switches.*

The Master A and B Level controls affect the overall level of each input. In other words, they allow all assigned outputs to be turned up or down at once. LEDs indicate an Overload (OL) at either the inputs or at the internal gain stages.

Each input is set to either Mic or Line level via the rear panel Input Pad pushbutton. The Input Gain pushbutton switches provide a microphone input with +60 or +40 dB of gain, or a line input with +20 or 0 dB of gain. With Input Gain, Master Levels and Output Levels, any reasonable input signal may be adjusted to a nominal +4 dBu and still have 17 dB of headroom. The Phantom Power switch provides +15 VDC for condenser microphones. *Any input assigned to line-level has this phantom voltage turned off automatically.* A rear-panel LED indicates when the Phantom Power is engaged.

Each output stage incorporates a high-current balanced output line driver for driving long lines with optimal performance.

Features

- *New!* A, B, A&B Output Assign Switches
- Sixteen Balanced Outputs, Individually Assignable
- Two Balanced Inputs
- Studio Grade Low Noise Input Amp
- Input Overload Indicators
- Mic/Line Input Switches
- Gain Switches: 40/60 dB Mic, 0/20 dB Line
- Phantom Power Switch
- Master Input and Individual Output Level Controls
- Stable High-Current Line Drivers
- All Outputs Capable of Driving 600 Ohm Loads Simultaneously
- #6 Screw Terminals
- UL/CSA/CE and 100/120/230 VAC Remote Power Supplies



Features and Specifications

| Parameter | Specification | Limit | Units | Conditions/Comments |
|-------------------------------|----------------------------|--------|-------|-------------------------------------|
| Mic Input Impedance | 1.82k | 1% | ohms | Balanced 909 + 909 |
| Line Input Impedance | 17.9k | 1% | ohms | Balanced 8.97k + 8.97k |
| Mic Gain Control | +40 & +60 | ±2 | dB | 2-position switch |
| Mic Pad | 20 | ±2 | dB | 2-position switch |
| Line Gain Range | 0 & +20 | ±2 | dB | 2-position switch |
| Overall Mic Gain | +56 & +76 | ±4 | dB | All controls maximum |
| Overall Line Gain | +16 & +36 | ±4 | dB | All controls maximum |
| Max Mic Input Level | -20 | typ | dBu | Gain at 40 dB |
| Max Line Input Level | +21 | typ | dBu | Gain at 0 dB |
| Overload LED | 3 dB below clip | typ | | Clip defined as 1% THD+N |
| Phantom Power | +15 | ±0.5 | VDC | Phantom Power switch active |
| Output Impedance | 200 | 1% | ohms | Balanced 100+100 |
| Output Drive Level | +24 | typ | dBu | 600 ohm load |
| Output Cable Length | 1500 | max | feet | Belden 8451 or equivalent |
| Mic Equivalent Input Noise | -128 | typ | dBu | Rs=150, gain=60 dB |
| Line Signal-To-Noise Ratio | 100 | min | dBV | gain=0 dB, re +4 dBu, 22 kHz BW |
| THD+Noise (Line Input) | 0.005 | typ | % | gain=0 dB, +4 dBu@1 kHz, 80 kHz BW |
| Frequency Response, Line | 15-50 kHz | +0, -3 | dB | 0 dB Gain, 0 dBu Output |
| Frequency Response, Mic | 15-50 kHz | +0, -3 | dB | 40 dB Gain, 0 dBu Output |
| Frequency Response, Mic | 30-50 kHz | +0, -3 | dB | 60 dB Gain, 0 dBu Output |
| Crosstalk | 80 | typ | dB | +4 dBu Output, 1 kHz |
| Unit: Agency Listing | | | | |
|120 VAC model | Class 2 Equipment | | | National Electrical Code |
| | UL | | | Exempt Class 2 equipment |
| | CSA | | | Exempt Class 2 equipment |
|230 VAC model | CE-EMC | | | EMC directive 89/336/EEC |
| | CE-Safety Exempt | | | Article 1 of LV Directive 73/23/EEC |
| Power Supply: Agency Listing | | | | |
|120 VAC model | UL | | | File no. E88261 |
| | CSA | | | File no. LR58948 |
|230 VAC model | CE-EMC | | | EMC directive 89/336/EEC |
| | CE-Safety | | | LV directive 73/23/EEC |
|100 VAC model | Built to JIS | | | Japan only |
| Power Supply Requirement | 18 VAC w/center tap | 10% | Vrms | RS 1 (see data sheet) |
|Maximum Current | 600 | | mA | RMS current from remote supply |
| Unit: Construction | All Steel | | | |
|Size | 1.75"H x 19"W x 5.3"D (1U) | | | (4.4 cm x 48.3 cm x 13.3 cm) |
|Weight | 4 lb | | | (2 kg) |
| Shipping: Size | 4.25" x 20.3" x 13.75" | | | (11 cm x 52 cm x 35 cm) |
|Weight | 8 lb | | | (5 kg) |
| <i>Note: 0 dBu=0.775 Vrms</i> | | | | |

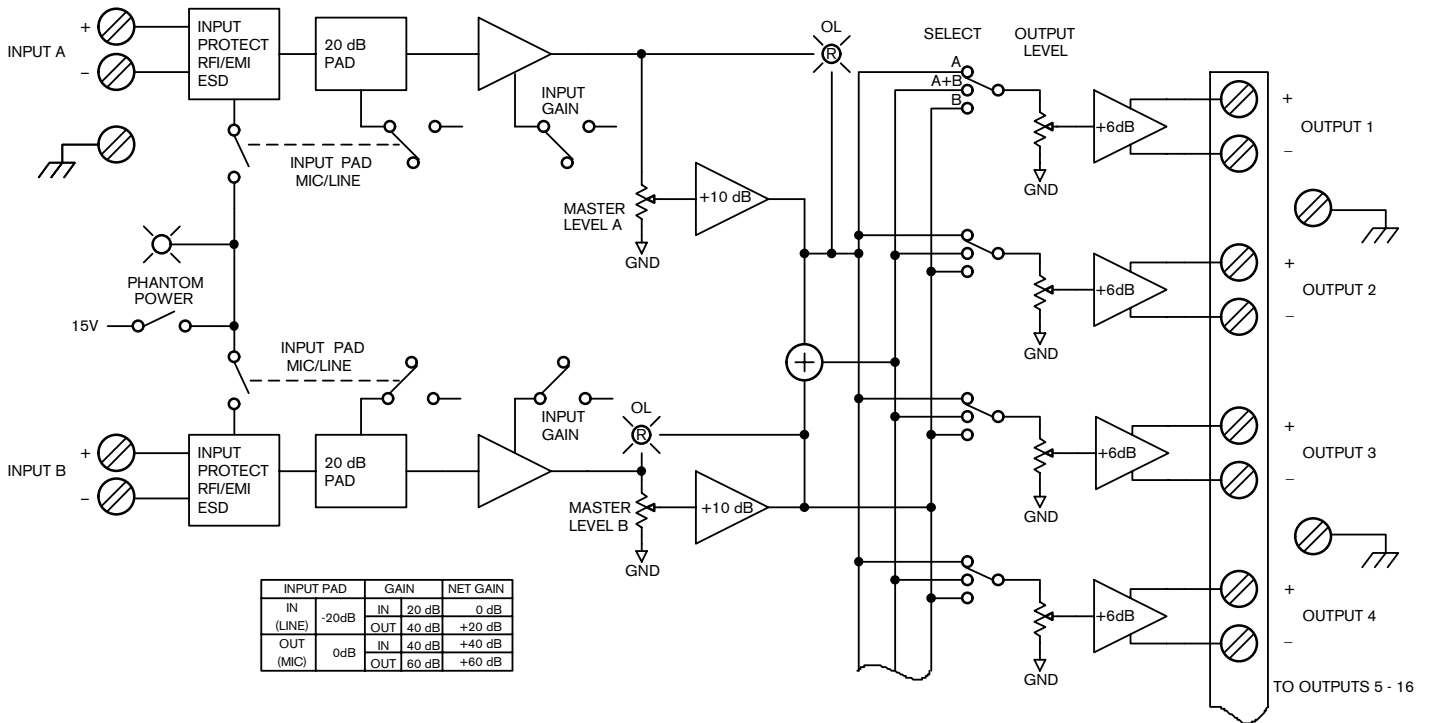

Applications

Use of the DA 216a is straightforward. Connect balanced inputs to the Input screw terminals. Follow the silk-screened labels to the balanced Output screw terminals. The terminals accept standard 8 millimeter (#6) spade lugs. Bare wire is acceptable by twisting the strands, inserting under the integrated square washer and tightening the screw.

The diagram shows the uncomplicated nature of the DA 216a. Fully balanced low-noise mic preamplifiers receive the signal to be split or distributed. The Input Pad pushbuttons change the input gain range. Additional Gain pushbuttons increase either Mic or Line level inputs another +20 dB (see table above).

Keep an eye on the Overload indicators when setting the gain. Always use the most gain possible without causing the Overload indicator to light. Occasional flickering is permitted. Setting gain this way maintains the best signal-to-noise performance for the system. The Master Level controls allow level matching and balancing as required.

When operating unbalanced, a 6 dB loss of signal must be taken into account when setting the gain structure of the system. *When wiring an Output for unbalanced operation do not ground the unused terminal (i.e. usually the “-”). Unbalanced uses only the “+” and ground terminals.*

32 Unbalanced Outputs Tip: The (“-”) Output may also be used as an unbalanced line driver, albeit inverted. The balanced Input terminals of the next stage must be reversed (+) for (-) to correct for the inversion. This nets a total of 32 Outputs! However, the penalty for 32 outputs is that unbalanced operation will not drive long lines and individual control is lost.

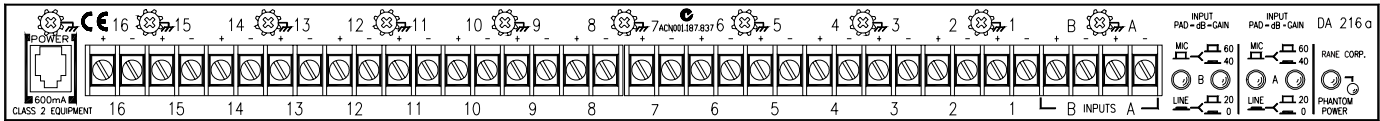
Rear Panel**Architectural Specifications**

The distribution amplifier shall have two (2) inputs and sixteen (16) outputs. The unit shall be capable of mono (16 mono outputs) or stereo operation (8 stereo outputs) via front panel switches. Each output shall be assignable to either or both of the master inputs.

Each input shall be microphone or line level switchable by means of rear panel switches. Additional 20 dB gain switches shall be built-in for each input, applicable to either a mic or line level signal. Each input shall have a front panel screwdriver level adjustment. 15V phantom power shall be pro-

vided via a rear panel switch for microphone inputs.

Each output shall have a front panel screwdriver adjustment. Inputs and outputs shall be active balanced screw terminal connectors.

The unit shall be exempt from agency safety requirements and powered from a UL listed / CSA certified (120 VAC), or CE approved (230 VAC) remote power supply. The unit shall be constructed entirely from cold-rolled steel, and mount into a standard 19" 1U EIA rack.

The unit shall be a Rane DA 216a Distribution Amplifier.

Available Accessories

- SC 1.7 Single Space Security Cover