

Application Information

Driving Impedances

Some people wrongly feel you cannot use a transformer to convert between -10 dBV and +4 dBu because of low impedances. This is not a problem as long as you use them to interconnect equipment with *at least 15 kΩ input impedance*. Since most professional products have input impedances of 20 kΩ or greater (50k and 100 kΩ are not uncommon), this should never be difficult. A 15 kΩ load winds up looking like 1 kΩ to the equipment with the -10 dBV output (due to transformer action). This may seem excessively low, but is not in practice. The maximum transformer output level of +24 dBu occurs with an input level of +10 dBV, which equals 3.16 volts. And 3.16 volts driving 1 kΩ only requires 3.16 milliamps, which is a very modest requirement for any -10 dBV equipment to deliver.

Wiring

The BB 44X follows AES/ANSI/IEC standards of pin 2 positive and pin 3 negative. Note the shields (commons) of the RCA jacks are tied for the Inputs and the Outputs but not to each other. This allows ground isolation of stereo Input and Output pairs. A positive signal applied to pin 2 of the 3-pin connectors causes a positive signal to appear on the tip of the associated RCA jacks, and vice-versa.

Signal Direction

Signal can be converted through the channels either direction. That means there is the possibility of having 4 channels -10 dBV unbalanced to +4 dBu balanced, or vice versa (in the standard unit). The only problem arises in the gender of the XLR connector. The solution requires same-sex XLR adaptors or special cables.

Chassis Grounding

A tapped hole and a #6-32 screw is provided for chassis grounding purposes. Good practice dictates earth-grounding the BB 44X. If the grounding integrity of the rack screws is in doubt, run a wire from this screw to a known earth ground.

Expansion Assembly

The OPT 88 (Option 88) expands the BB 44X into an eight channel model. The OPT 88 consists of a printed circuit board with four additional transformers and jacks soldered in place. The OPT 88 installs easily in the blank side of the BB 44X. Assembly is simple: remove the cover, install the board in place, and secure with the supplied mounting screws. No soldering required; all you need are #1 and #2 Phillips screwdrivers. See the illustration on the next page.

The OPT 88 may be used in some environments without the BB 44X, however best RFI rejection is obtained using the cold rolled steel metal chassis of the BB 44X.

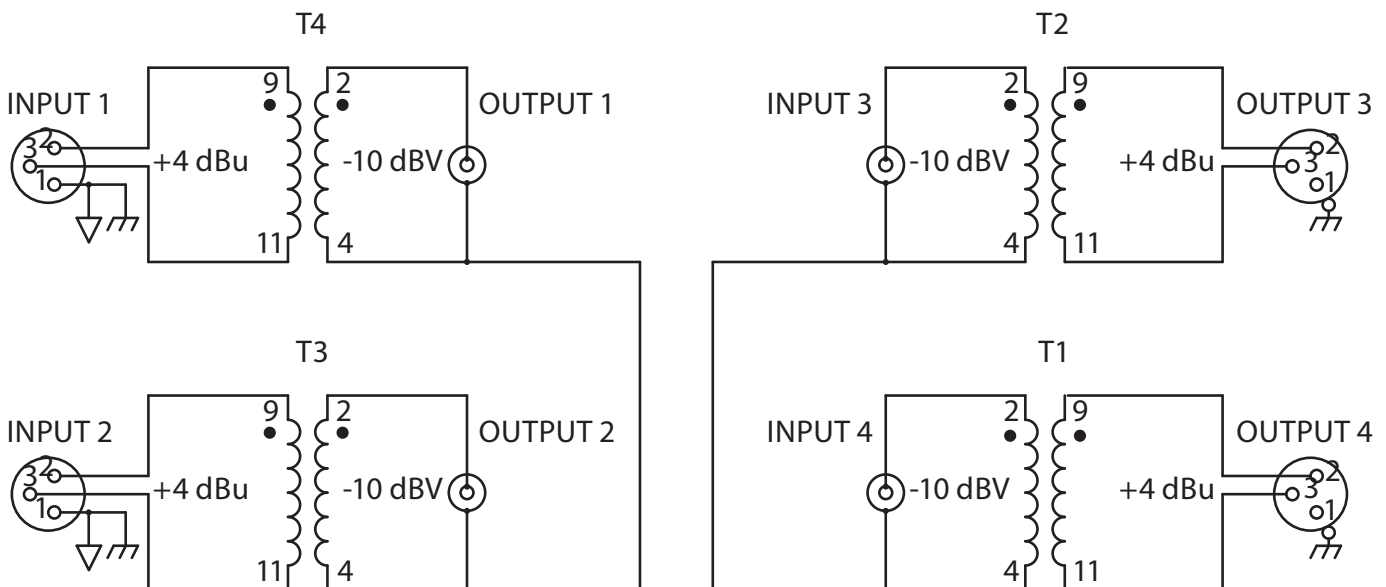



WARNING: This product may contain chemicals known to the State of California to cause cancer, or birth defects or other reproductive harm.

Parameter	Specification	Limit	Units	Conditions/Comments
Transformer Construction	Nickel Core Bobbin Wound			
Turns Ratio	1:3.89			Grade "80" Ni
Maximum Levels	(In or Out)			-10 dBV (316 mV); +4 dBu (1.23 V)
.....-10 dBV	+10 (40 Hz-20 kHz); +4.5 (20 Hz)	0.5dB	dBV	1% THD point
.....+4 dBu	+24 (40 Hz-20 kHz); +18.5 (20 Hz)	0.5dB	dBu	1% THD point
Input Impedance	(Load impedances as shown)			
.....-10 dBV	1k	5 %	Ω	Load impedance 15 kΩ
.....+4 dBu	15k	5 %	Ω	Load impedance 1 kΩ
Insertion Loss	0.5	0.1	dB	With recommended load impedance
DC Resistance	47.5 / 200	10%	Ω	-10 dBV / +4 dBu
Frequency Response	20 Hz -20 kHz	±2	dB	+4 dBu In or Out; rec. load impedance
THD + Noise	less than .05 (40 Hz-20 kHz)	max	%	+4 dBu In or Out
Unit: Conformity	CE, FCC			Exempt
.....Size	1.75"H x 19"W x 5.3"D (1U)			(4.4 cm x 48.3 cm x 13.3 cm)
.....Weight	4 lb			(3 kg)
Shipping: Size	4.25" x 20.3" x 13.75"			(11 cm x 52 cm x 35 cm)
.....Weight	8 lb			(5 kg)

All specifications apply both directions, unless noted.

INSTALLATION INSTRUCTIONS:

1. REMOVE THE (7) TOP COVER SCREWS.
2. REMOVE TOP COVER.
3. INSTALL PCB ASSEMBLY INTO CHASSIS.
4. INSTALL THE (11) REAR PANEL SCREWS.
(9) M2.9 X 5/16" AND (2) 4-40 X 1/4"
5. INSTALL THE (2) BOTTOM SCREWS.
6. REPLACE TOP COVER.
7. REPLACE THE (7) TOP COVER SCREWS.
8. PLUG AND PLAY.

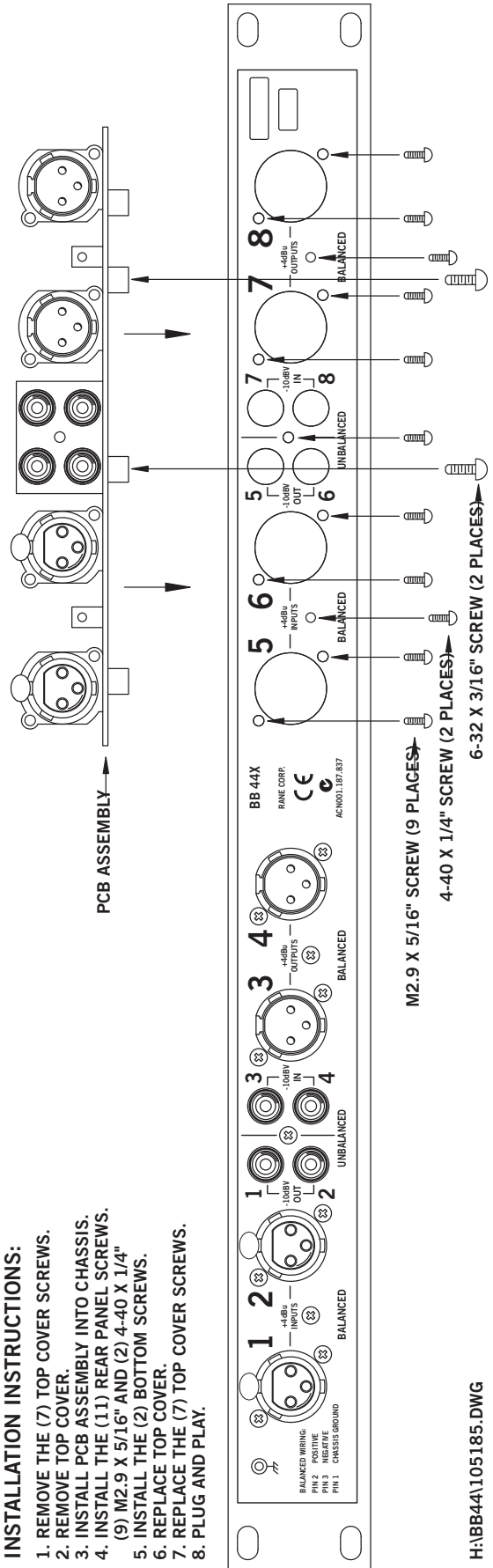

H:\BB44\105185.DWG