

General Description

The Rane AVA 22d is a fully balanced two Input, two Output Audio / Video Alignment Delay providing a range of 0.0 to 9.5 NTSC or PAL/SECAM frames on each Output. 24-bit audio converters provide excellent sound quality.

Each Output has two nonvolatile Memories (no batteries required), A and B, for easy access to previously stored Delay values. Remote Recall screw terminals on the rear accept external configuration switches, permitting independent remote recall of the Memories.

The AVA 22d features XLR Inputs and Outputs, and is CE certified for emissions. Housed in a single rack space, the unit can operate as two independent channels (dual mono), or as a stereo pair (edit both channels simultaneously using Link Mode).

A recessed rear panel switch is available for locking out front panel controls. In this mode, all of the front panel pushbuttons are disabled with the exception of the Recall buttons. The Recall buttons remain active so the user may view the Delay values

without risk of changing them. Internal jumpers are available to enable or disable Bypass while in Front Panel Lockout mode. The default setting of these jumpers *disables* Bypass in Front Panel Lockout mode.

Independent bypass relays provide a fail safe, hard-wired bypass in case of power loss.

The AVA 22d is a unity gain device with Sensitivity controls to provide proper internal levels for the audio converters. If the input signal is nominally +4 dBu, set the Sensitivity control fully counter clockwise (+4 dBu). For those unable to touch a cable and determine its signal level, Signal present and Clip indicators provide visual acknowledgment that the Input signal is within optimal range.

Powered from a low voltage UL listed and CSA certified remote power supply (230 VAC supply meets LVD 73/23/EEC), the AVA 22d is exempt from safety agency requirements, and may be used in any installation mandating agency compliance.

Features

- 0 to 9.5 NTSC or PAL/SECAM Frames Delay per Channel
- Two Independent Channels (2 In - 2 Out)
- Single-Field (half-frame) Increments
- Independent Remote Memory Recall Interface on Rear
- Two EEPROM Memories per Channel (No Batteries)
- Front Panel Lockout Switch on Rear
- Fail-Safe Bypass for Each Channel
- Active Balanced XLR Inputs & Outputs
- UL/CSA/CE and 100/120/230 VAC Remote Power Supplies



Features and Specifications

Parameter	Specification	Limit	Units	Conditions/Comments
Delay Range	0.0 to 9.5	1%	frames	33.3 msec/frame, NTSC 40 msec/frame, PAL/SECAM
.....Increment Size	1 field (half-frame)		frames	Independently controllable
.....Readout	2 digit LED			
Propagation Delay	1.42	1%	msec	
Sampling Frequency	50k		Hz	
Data Conversion	24		bit	
Input & Output Connectors	XLR			
Inputs: Type	Active balanced			
.....Impedance	25k	1%	Ω	balanced
.....Headroom	16 above Sensitivity setting	2	dB	20 Hz - 8 kHz
.....Max Level	20		dBu	1 kHz with Sensitivity at +4 dBu
Outputs: Type	Active balanced cross-coupled			
.....Impedance	200	1%	Ω	balanced
.....Max Level	22 (>2 kΩ); 20 (>600 Ω)		dBu	1 kHz with Sensitivity at +4 dBu
Overall System Gain	0	±1	dB	600 Ω balanced load
Output Relays	Yes			Auto-bypass with power loss
LED Thresholds: Clip	4 before converter overload	1	dB	1 kHz
.....Signal Present	-34 below Clip LED	1	dB	1 kHz
Frequency Response	20 Hz - 20 kHz	+0/-0.5	dB	+4 dBu, Sens@+4
THD + Noise	0.05	.01	%	+4 dBu, Sens@+4, 20-20k, 30k Hz BW
Signal-to-Noise Ratio	85	2	dB	+4 dBu, Sens@+4, 20 Hz - 20 kHz
Dynamic Range	101	2	dB	+4 dBu, Sens@+4, 20-20k, A-weighted
Crosstalk	>90		dB	20-20 kHz, +4 dBu, Sens @ +4 dBu
Unit: Agency Listing				
.....120 VAC model	Class 2 Equipment UL & CSA			National Electrical Code Exempt Class 2 equipment
.....230 VAC model	Certified FCC Part 15J			Class B Device
Power Supply: Agency Listing				
.....120 VAC model	UL CSA			File no. E88261 File no. LR58948
.....230 VAC model	CE-EMC CE-Safety			EMC directive 89/336/EEC LV directive 73/23/EEC
Power Supply Requirement	18 VAC w/center tap	0.1	Vrms	Rane RS 1
.....Maximum Current	650		mA	RMS current from remote supply
Unit: Construction	All Steel			
.....Size	1.75"H x 19"W x 8.5"D (1U)			(4.4 cm x 48.3 cm x 21.6 cm)
.....Weight	6 lb (w/o power supply)			(2.7 kg)
Shipping: Size	4.25" x 20.3" x 13.75"			(11 cm x 52 cm x 35 cm)
.....Weight	10 lb			(4.5 kg)
<i>Note: 0 dBu=0.775 Vrms</i>				

Block Diagram

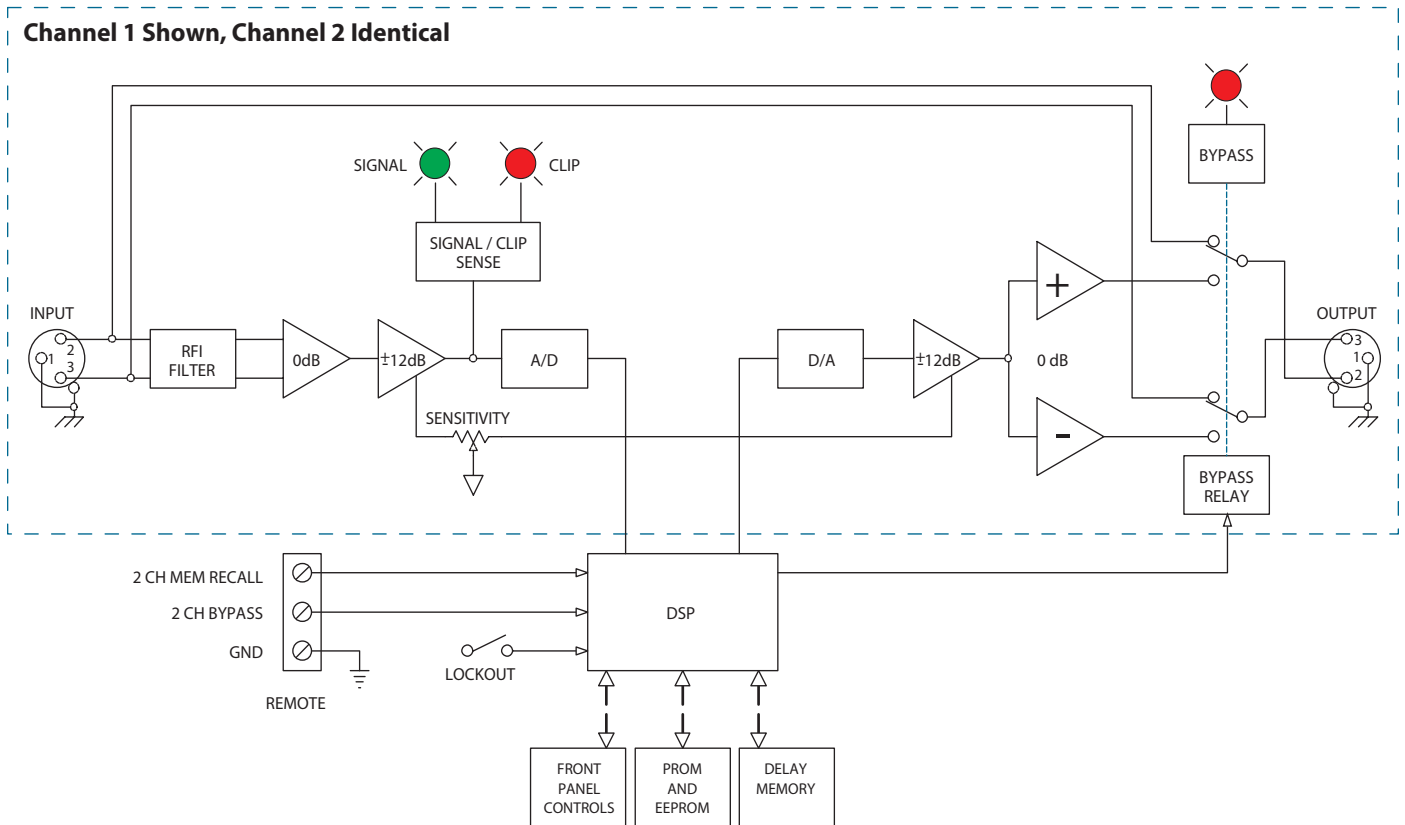

Application Information

The AVA 22d provides a cost-effective solution to the problem of aligning audio to video in broadcast. Accumulated delays can run as high as several frames, creating objectionable synchronization problems. Audio preceding video by even one frame is detectable by some people. The high cost of existing audio/video synchronizers prevents many broadcasters from correcting all synchronization problems adequately. Satellite links also add to the synchronization problem since the audio can be transmitted through a separate medium than the video. An additional problem is the inherent HD video processing delay found in HDTV monitors at home, which varies by manufacturer and model. The AVA 22d's maximum delay of 9.5 NTSC or PAL/SECAM frames provides any of these complex systems with a cost effective delay solution with very high quality.

The AVA 22d operates as either a dual mono or stereo device. Link mode provides simple stereo operation, linking both channels together with easy one-button editing of both channels' parameters. In dual mono mode the two channels are completely independent allowing simultaneous operation in two separate mono production rooms. The Remote Recall terminals can be internally configured allowing the remote room to independently access the two configuration memories.

The AVA 22d supports both NTSC and PAL/SECAM broadcast modes. This broadcast mode is stored in configuration memory with the delay values allowing recall of NTSC values from one memory and PAL/SECAM values from the other. Video houses providing NTSC to PAL (and vice versa) conversion find this feature particularly useful. (Those working on Godzilla sequels should contact the factory for special synchronization procedures.)

Rear Panel

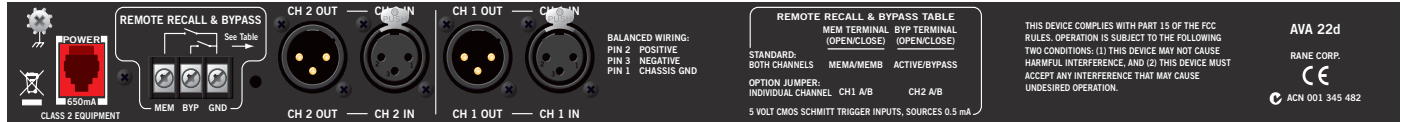

Architectural Specifications

The digital audio delay unit shall be a single rack space, two input, two output configuration. The delay adjustment range shall be from 0.0 to 9.5 NTSC or PAL/SECAM frames, adjustable via increment/decrement pushbuttons, in field (half-frame) increments. Independent remote recall terminals shall be provided for external stereo bypassing and recall of stored configuration memories, two per channel. A two (2) digit LED display shall indicate delay values in frames as well as software revision level. Bypass status, current memory, channel, and display modes shall be indicated with individual indicators.

A recessed rear-panel switch shall disable the front panel, yet still allow viewing of delay values.

Independent input-output sensitivity controls shall be included to allow calibration of the input signal for maximum

performance. The inputs and outputs shall be active balanced with XLR connectors. Each channel shall have indicators for signal present and input/output clip conditions.

The unit shall provide independent, fail-safe bypass relays requiring no power to engage. RFI filters shall also be provided.

The unit shall have certified compliance with FCC docket 20780 Part 15J for Class B computing devices. The AVA 22d shall comply with EMCD 89/336/EEC (CE approved). The 120 VAC model shall be powered from a UL listed, CSA certified remote power supply, and the 230 VAC model shall be powered from a remote power supply meeting LVD 73/23/EEC and EMCD 89/336/EEC standards. The unit shall be constructed entirely from cold-rolled steel.

The unit shall be a Rane Corporation AVA 22d.

600Ω user information

The AVA 22d's inputs are specified for a nominal +4 dBu input, which is a voltage referenced level of 1.228 Volts rms (0 dBu = 0.7746 Volts). At this voltage level, the AVA 22d provides 16 dB of headroom below 8 kHz. Users who wish to operate the AVA 22d in 600Ω systems must provide their own 600Ω input resistor across the input terminals. This enables the AVA 22d to accept a +4 dBm input and allows delivery of +4 dBm to a 600Ω load. Confusion among 600Ω users of the AVA 22d may occur if one assumes the input and output impedances of the AVA 22d are 600Ω – they are not. Therefore, when evaluating the AVA 22d do not assume that +4 dBm equals +4 dBu unless you have ensured that all input and output impedances in your test setup are 600Ω.

Advantages of Hi-Z in/Lo-Z out systems:

(from *Audio System Design and Installation*, by Phillip Giddings, Howard W. Sams, 1990, pp. 129-130.)

1. Less distortion in output due to smaller output current needs.
2. About 14 dB lower noise pickup by interconnecting lines due to lower source impedance.
3. Greater lengths of cable may be driven for a given high frequency roll-off.
4. Many pieces of equipment can be driven from one output without the use of distribution amplifiers, with no concern for matching or level changes.
5. Better reliability resulting from less heat generation due to less power drawn from the output stage.
6. In the event that a 600Ω load termination is used the delivered voltage will only drop by about 1 dB (20 log [R1/(R1+RS)]).
7. Greater signal voltage swing as 6 dB of signal is not lost in the (600Ω) source impedance.
8. Smaller currents reduce inductive coupling and crosstalk between cables.