

General Description

The Rane AVA 22 Audio/Video Alignment Delay is a fully balanced two Input, two Output audio alignment delay providing a range of 0.0 to 9.5 NTSC frames (8.0 PAL/SECAM frames) on each Output. The Delay of each Output is independently adjustable in field (half-frame) increments. Each Output has two nonvolatile Memories, A and B, for easy access to previously stored Delay values.

The AVA 22 features XLR connectors. Remote terminals on the rear accept external configuration switches, permitting independent stereo bypassing and stereo remote recall of Memories. An internal jumper is provided to reconfigure the Remote terminals for independent recall of the two Channels' stored Memories.

Housed in a single rack space the AVA 22 can be operated as two independent Channels (dual mono) or as a stereo pair of Channels (LINK mode).

The AVA 22 employs the Dolby™ Time Link 1-bit delta-sigma encode/decode circuit; the same circuit used in many Dolby surround sound decoding units for home theater systems. This ensures the highest possible audio quality throughout the system.

Both NTSC and PAL/SECAM broadcast standards are supported.

A recessed rear panel switch is available for locking out front panel controls. In this mode, all of the front panel pushbuttons are disabled with the exception of the Recall buttons. The Recall buttons remain active so the user may view the stored Delay values without risk of changing them. Internal jumpers enable or disable Bypass while in Front Panel Lockout mode. The default setting of these jumpers disables Bypass in Front Panel Lockout mode.

Independent bypass relays provide a fail safe, hard-wired bypass in case of power loss.

The AVA 22 is a unity gain device with Sensitivity adjustment controls to provide proper internal levels for the Dolby™ Time Link circuit. If the input signal is nominally +4 dBu, set the Sensitivity control fully counter-clockwise (+4 dBu). For those unable to touch a cable and determine its signal level, Signal present and Clip LEDs provide visual indication that the Input signal is within optimal range.

Powered from a low voltage UL listed, CSA certified remote power supply (230 VAC model meets LVD 73/23/EEC), the AVA 22 is exempt from safety agency requirements, and may be used in any installation mandating agency compliance.

Dolby and the double-D symbol are trademarks of Dolby Laboratories Licensing Corporation.

Features

- 1-Bit Dolby™ Time Link Conversion
- Two Independent Channels (2 In - 2 Out)
- 0 to 9.5 NTSC Frames Delay Range per Channel
- 0 to 8.0 PAL/SECAM Frames Delay Range per Channel
- Single Field (Half-Frame) Increments
- Front Panel Lockout Switch on Rear
- Independent Remote Memory Recall Interface on Rear
- Active Balanced XLR Inputs & Outputs
- Two EEPROM Memories per Channel (No Batteries)
- Fail-Safe Bypass for Each Channel
- UL/CSA Remote Power Supply (120 VAC)
- CE (Low Voltage & EMC) Remote Power Supply (230 VAC)

Parameter	Specification	Limit	Units	Conditions/Comments
Delay Range NTSC	0.0 to 9.5	1%	frames	33.3 msec/frame (30 frames/sec)
.....PAL/SECAM	0.0 to 8	1%	frames	40 msec/frame (25 frames/sec)
.....Increment Size	1 Field (½ Frame)			
.....Readout	2 digit LED			
Propagation Delay	11.3	0.1	µsec	
Sampling Frequency	3.2 MHz			
Data Conversion	1-bit Dolby™ Time Link			
Input & Output Connectors	XLR			
Inputs: Type	Active Balanced			Instrumentation type
.....Impedance	20k Balanced	1%	ohms	
.....Headroom	16 above Sensitivity setting	2	dB	20 Hz-8 kHz
	7 above Sensitivity setting	2	dB	20 kHz
.....Max Nominal Level	4		dBu	20-8 kHz, Sens@+4 dBu
Outputs: Type	Active Balanced			
.....Impedance	200 Balanced	1%	ohms	
.....Max Voltage Level	20 (=>600 ohm load)		dBu	20 Hz - 8 kHz, Sens@+4 dBu
	12		dBu	at 20 kHz, Sens@+4 dBu
.....Nominal Output Power	4		dBm	600 ohm load
Overall System Gain	0	±1	dB	600 ohm load
	2.5	±1	dB	>2k ohm load
Output Relays	Yes			Auto-Bypass with power loss
LED Threshold - Clip	5 before Converter Overload	1	dB	1 kHz
LED Threshold - Signal Present	-37 below Clip LED	1	dB	1 kHz
Frequency Response	20-8 kHz	±0.5	dB	+4 dBu, Sens@+4
	8k-20 kHz	±1.5	dB	+4 dBu, Sens@+4
THD + Noise	0.1	.05	%	+4 dBu, Sens@+4, 1 kHz, 30k BW
	0.2	.1	%	+4 dBu, Sens@+4, 20-20k, 30k BW
Signal-to-Noise Ratio	92	2	dB	+4 dBu, Sens@+4, CCIR-2k
	82	2	dB	+4 dBu, Sens@+4, 20-20 kHz
Dynamic Range	98	2	dB	Sens@+4, 20 Hz-8 kHz
	90	2	dB	Sens@+4, 8k-20 kHz
	108	2	dB	Sens@+4, 20-20 kHz, CCIR-2k
Crosstalk	>85 @ 1 kHz, >64 @ 20 kHz		dB	+4 dBu, Sens@+4
Power Supply Requirement	18 VAC w/center tap	10%	Vrms	RS 1 (supplied)
Maximum Current Demand	650		mA	RMS current from remote supply
Unit: Agency Listing				
.....120 VAC model	Class 2 Equipment UL & CSA			National Electrical Code Exempt Class 2 equipment
.....230 VAC model	CE-EMC CE-Safety			EMC directive 89/336/EEC Exempt per Art. 1, LVD 73/23/EEC
EMI/RFI Emission Level	Certified FCC Part 15J			Class A Device
Power Supply: Agency Listing				Class 2 Equipment
.....120 VAC model	UL CSA			File no. E88261
.....230 VAC model	CE-EMC CE-Safety			File no. LR58948 EMC directive 89/336/EEC LV directive 73/23/EEC
.....100 VAC model	Built to JIS			Japan only
Unit: Construction	All Steel			
.....Size	1.75"H x 19"W x 8.5"D (1U)			(4.4 cm x 48.3 cm x 21.6 cm)
.....Weight	6 lb (w/o power supply)			(2.7 kg)
Shipping: Size	4.5" x 20.3" x 13.75"			(11.5 cm x 52 cm x 35 cm)
.....Weight	10 lb			(4.5 kg)
<i>Note: 0 dBu = 0.775 Vrms</i>				

Block Diagram

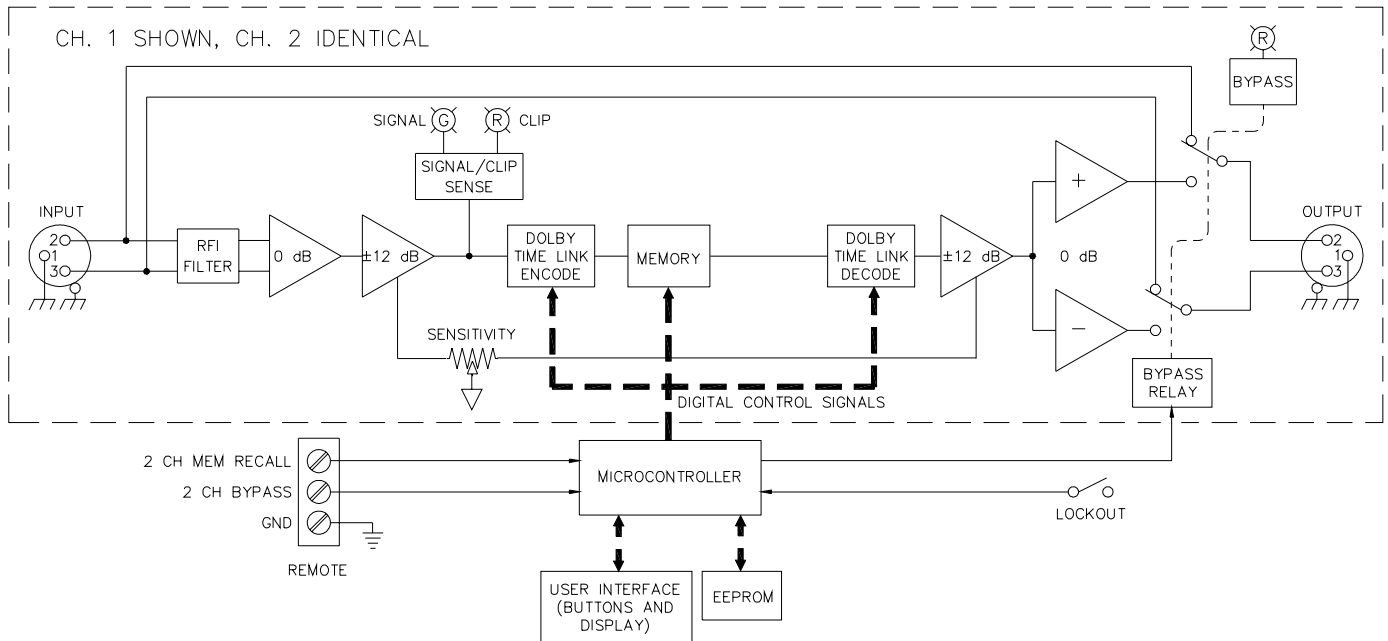

Application Information

The AVA 22 provides a cost-effective solution to the problem of aligning audio to video in broadcast. Modern video processing creates unavoidable time delays between audio and video signals. Accumulated delays can run as high as several frames, creating objectionable synchronization problems. Audio preceding video by even one frame is detectable by some people. The high cost of existing audio/video synchronizers prevents many broadcasters from correcting all synchronization problems adequately. Satellite links also add to the synchronization problem since the audio can be transmitted through a separate medium than the video. The AVA 22's maximum delay of 9.5 NTSC (8.0 PAL/SECAM) frames provides these complex systems with a cost effective delay solution. Rane offers the AVA 22 to answer the need for a low cost, high quality, audio/video alignment delay.

The AVA 22 operates as either a dual mono or stereo device. Link mode provides simple stereo operation, linking both Channels together with easy one-button editing of both Channels' parameters. In dual mono the two Channels are completely independent allowing simultaneous operation in two separate mono production rooms. The Remote Recall terminals can be internally configured allowing the remote room to independently access the two configuration memories.

The AVA 22 supports both NTSC and PAL/SECAM broadcast modes. This broadcast Mode is stored in configuration memory with the delay values allowing recall of NTSC values from one memory and PAL/SECAM values from the other. Video houses providing NTSC to PAL (and vice versa) conversion find this feature particularly useful. (Those working on Godzilla sequels should contact the factory for special synchronization procedures.)

600 ohm user information

The AVA 22's inputs are specified for a nominal +4 dBu input, which is a voltage referenced level of 1.228 Volts RMS. (0 dBu = 0.7746 Volts). At this voltage level, the AVA 22 provides 16 dB of headroom below 8 kHz. Users who wish to operate the AVA 22 in 600 ohm systems must provide their own 600 ohm input resistor across the input terminals. This enables the AVA 22 to accept a +4 dBm input and allows delivery of +4 dBm to a 600 ohm load. Confusion among 600 ohm users of the AVA 22 may occur if one assumes the input and output impedances of the AVA 22 are 600 ohms – they are not. Therefore, when evaluating the AVA 22 do not assume that +4 dBm equals +4 dBu unless you have ensured that all input and output impedances in your test setup are 600 ohms.

Advantages of Hi-Z in/Lo-Z out systems:

(from *Audio System Design and Installation*, by Phillip Giddings, Howard W. Sams, 1990, pp. 129-130.)

1. Less distortion in output due to smaller output current needs.
2. About 14 dB lower noise pickup by interconnecting lines due to lower source impedance.
3. Greater lengths of cable may be driven for a given high frequency roll-off.
4. Many pieces of equipment can be driven from one output without the use of distribution amplifiers and with no concern for matching or level changes.
5. Better reliability resulting from less heat generation due to less power drawn from the output stage.
6. In the event that a 600 ohm load termination is used the delivered voltage will only drop by about 1 dB ($20 \log [R1/(R1+RS)]$).
7. Greater signal voltage swing as 6 dB of signal is not lost in the (600 ohm) source impedance.
8. Smaller currents reduce inductive coupling and crosstalk between cables.

Rear Panel

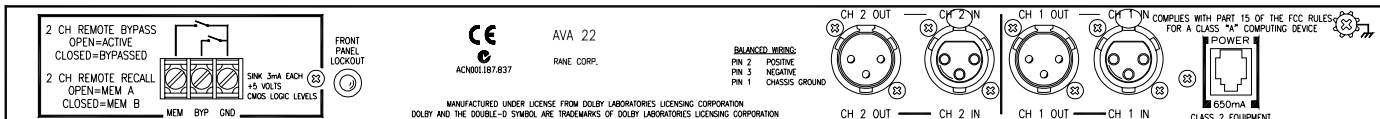

Architectural Specifications

The digital audio delay unit shall be a single rack space, two Input, two Output configuration. The delay adjustment range shall be from 0.0 to 9.5 NTSC frames (8.0 PAL/SECAM frames), adjustable via increment/decrement pushbuttons, in field (half-frame) intervals. The method of delay shall be the Dolby Time Link 1-bit delta-sigma encode/decode circuit. Independent remote recall terminals shall be provided for external stereo bypassing and stereo recall of stored configuration memories, two per channel. A two (2) digit LED display shall indicate delay values in frames as well as software revision level. For each channel, individual LEDs shall indicate Bypass status, current Memory, broadcast Mode (NTSC or PAL/SECAM) and overall Link status.

A recessed rear-panel switch shall disable the front panel, yet still allow viewing of stored delay values.

Independent input-output Sensitivity controls shall be included to allow calibration of the input signal for maximum performance. The inputs and outputs shall be active balanced, terminated with XLR connectors. Each channel shall have LEDs to indicate Signal present and input/output Clip conditions.

The unit shall provide independent, fail-safe Bypass relays requiring no power to engage. RFI filters shall also be provided.

The unit shall have certified compliance with FCC docket 20780 Part 15J for Class A computing devices, and EMC 89/336/EEC. The 120 VAC model shall be powered from a UL listed, CSA certified remote power supply; the 230 VAC model shall be powered from a remote power supply meeting LVD 73/23/EEC & EMC 89/336/EEC standards. The chassis shall be constructed entirely from cold-rolled steel.

The unit shall be a Rane Corporation AVA 22.