



General Description

The Rane AC 23B Active Crossover can be configured as a stereo 2- or 3-way, or a mono 4- or 5-way. It employs 4th-order Linkwitz-Riley filter alignments to minimize phase difficulties in the critical crossover region. The AC 23B uses XLR connectors with active balanced Inputs and Outputs.

Simply put, a Linkwitz-Riley alignment is two cascaded 2nd-order Butterworth filters exhibiting identical phase characteristics on their low-pass and high-pass outputs. This characteristic guarantees in-phase outputs at all frequencies. In-phase outputs are mandatory for proper acoustic summing of common signals from adjacent drivers in the crossover region. An added benefit of this topology is steep 24 dB per octave rolloff slopes. A slope of this magnitude guarantees drivers designed to produce a specific range of frequencies, and no more, will not be driven past their

limits, thereby minimizing distortion and driver fatigue.

To further guarantee the transparent operation of the AC 23B, adjustable Delay circuits appear on the Low & Mid Outputs of each Channel to compensate for any physical misalignment of the drivers. Time correction ensures the mechanical phase alignment of adjacent drivers will be acoustically correct, thus maintaining the integrity of the electrical phase alignment of the crossover's filters.

In 2- or 3-way stereo mode, the low outputs may be mono'ed by moving an internal jumper. Constant directivity (CD) horn equalization is possible with an internal modification. See the manual for details.

See the RaneNote *Linkwitz-Riley Crossovers* for more information, available at www.rane.com.

Features

- Stereo 2- or 3-Way, Mono 4- or 5-Way
- Linkwitz-Riley Alignment with 24 dB per Octave Slopes
- Adjustable Delays
- Infrasonic, Ultrasonic and RFI Filters
- Low & Mid Output Muting (3-Way)
- Input & Output Level Controls
- Fully Active Balanced XLR Inputs & Outputs
- UL/CSA/CE and 100/120/230 VAC Remote Power Supplies



Features and Specifications

Parameter	Specification	Limit	Units	Conditions/Comments
Crossover: Alignment	Linkwitz-Riley			Proprietary 4th-order state-variable
.....Slopes	24 dB per Octave			
.....Range (3-way)	70-1 kHz Low to Mid			41-detent continuously variable pot
.....Range (3-way)	190-7 kHz Mid to High			as above
.....Range (2-way)	190-7 kHz Low to High			as above
Time Delay Adjust Range	Off to +2	5%	ms	Low & Mid Outputs only
Inputs: Impedance	20k	1	Ω	
.....Maximum Level	+21	1	dBu	
.....Gain Range	Off to +6	-0/+4	dB	
Inputs: Type	Active Balanced XLR			Pin 2 hot per AES standards
Outputs: Type	Active Balanced XLR			Pin 2 hot per AES standards
.....Impedance	200	1%	Ω	
.....Maximum Level	+20	1	dBu	600 Ω or greater
.....Gain Range	Off to +12	-0/+4	dB	
Band Muting Switches	Yes			Low & Mid Outputs only
RFI Filters	Yes			
Infrasonic Filter	20 Hz, 18 dB/Oct, Butterworth	3%	Hz	
Ultrasonic Filter	40 kHz, 18 dB/Oct, Bessel	3%	Hz	Linear phase
Frequency Response	20-40 kHz	+0/-3	dB	
THD+Noise	0.02	.01	%	+4 dBu, 20-20 kHz
IM Distortion (SMPTE)	0.02	.01	%	60 Hz / 7 kHz, 4:1, +4 dBu
Signal-to-Noise Ratio	92	2	dB	re +4 dBu, 20 kHz noise bandwidth
Unit: Agency Listing				
.....120 VAC model	Class 2 Equipment UL & CSA			National Electrical Code Class 2
.....230 VAC model	VDE, SELV CE-EMC CE-Safety			Safety Extra Low Voltage EMC directive 89/336/EEC Exempt per Art. 1, LVD 73/23/EEC
Power Supply: Agency Listing				
.....120 VAC model	UL CSA			File no. E88261 File no. LR58948
.....230 VAC model	CE-EMC CE-Safety			EMC directive 89/336/EEC LV directive 73/23/EEC
.....100 VAC model	Built to JIS			Japan only
Power Supply Requirement	18 VAC w/center tap	0.1	Vrms	Model RS 1
Maximum Current	750		mA	RMS Current from Remote Supply
Unit: Construction	All Steel			
.....Size	1.75" H x 19" W x 5.3" D (1U)			(4.4 cm x 48.3 cm x 13.3 cm)
.....Weight	5 lb			(2.3 kg)
Shipping: Size	4.25" x 20.3" x 13.75"			(11.5 cm x 52 cm x 35 cm)
.....Weight	9 lb			(4.1 kg)
<i>Note: 0 dBu=0.775 Vrms</i>				

Block Diagram

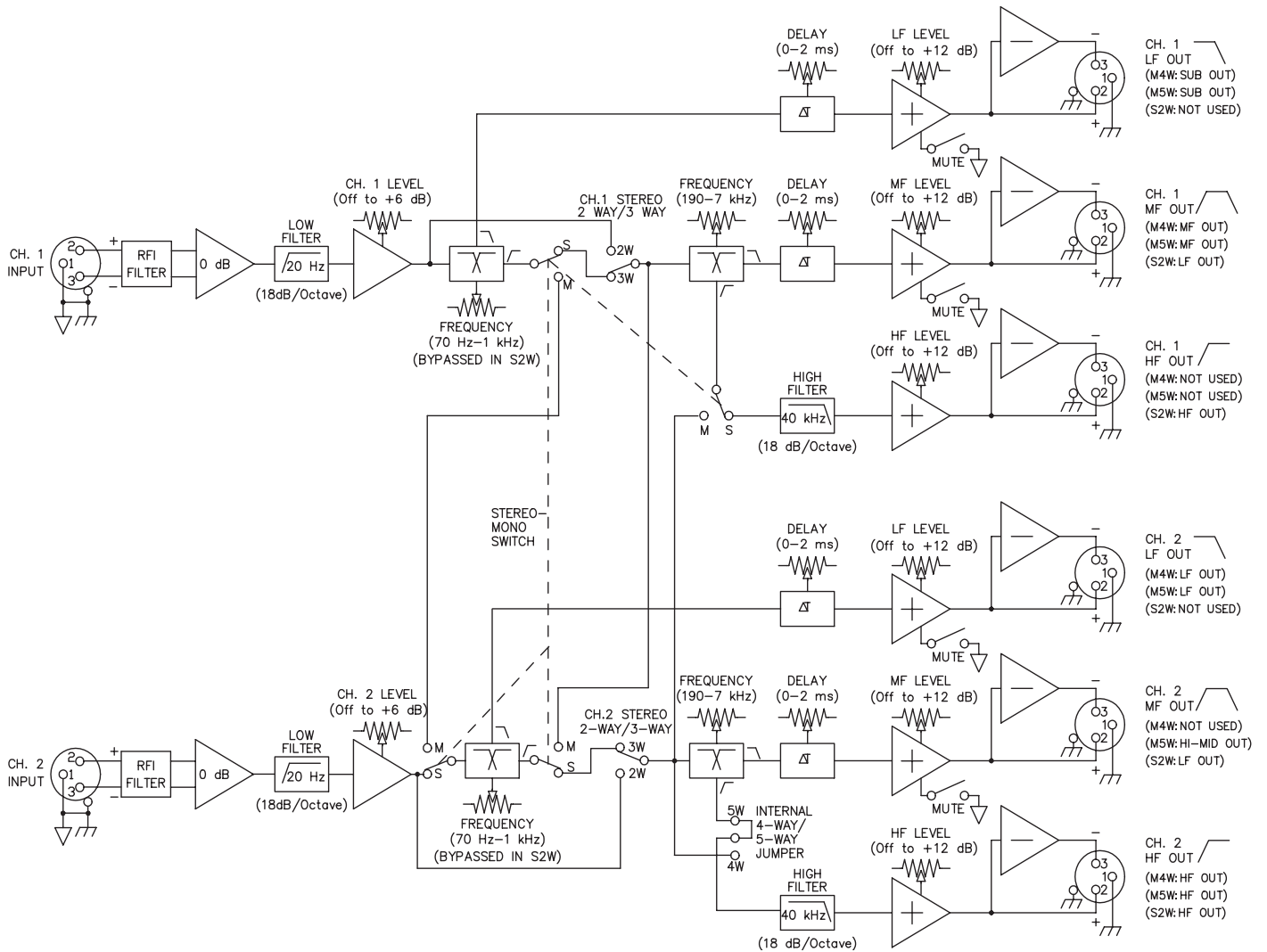

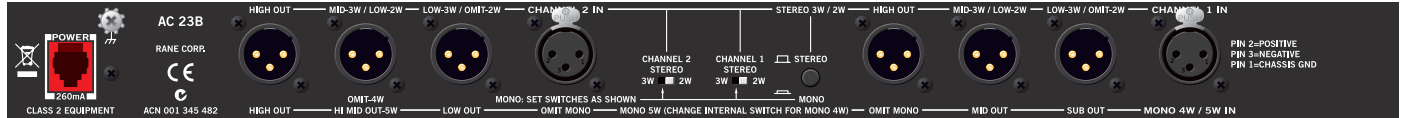
Rear Panel

Choosing the Right Configuration: Mono, Dual Mono, or Stereo? Architectural Specifications

Very few systems indeed will utilize a two channel crossover for the purpose of true stereo imaging. Discrete stereo channels which are run from the mixing board are usually used for panning effects and/or for separate equalization of left and right speaker stacks. Different sides of the room often require significantly different equalization due to varying room acoustics, dimensions, positioning of speaker stacks near walls, curtains and the like.

Even though you may not plan to use stereo equalization or panning effects, it is recommended that your system utilize discrete crossover channels for each stack of speakers to ensure flexibility and control for consistent, optimum sound quality. For example, if you plan to run a multi-stack system mono three-way, use the AC 23B rather than the AC 22B for separate control over each set of speakers—especially since phase alignment may differ with each stack requiring separate time delay adjustments. Even with only a single system equalizer, the AC 23B can deliver the extra independent control which can make a difference in sound throughout the listening area. If all drivers are built into a single cabinet, or you are running bi-amped monitors, then the AC 22B is the one for you.

The active crossover shall contain 4th-order Linkwitz-Riley filters. Provisions shall exist to correct for driver misalignment by adding time delay to the low and mid frequency outputs.

The crossover frequency shall be controlled by a continuously variable control with 41 detents to allow mechanical reference of crossover setting.

Signal inputs and outputs shall be of active balanced design terminated with XLR connectors. RFI, infrasonic, and ultrasonic filters shall be built-in.

The active crossover shall afford an input level range of Off to +6 dB. The output level controls shall afford a level range of from Off to +12 dB with muting capability on the low and mid frequency outputs. The crossover shall supply two independent channels.

The unit shall be exempt from agency safety requirements and powered from a UL listed, CSA certified remote power supply (120 VAC) or CE approved (230 VAC) via a rear panel modular plug input. The unit shall be constructed entirely from cold-rolled steel, and mount into a standard 1U EIA rack.

The unit shall be a Rane Corporation AC 23B Active Crossover.

Available Accessories

- SC 1.7 Security Cover

References

1. S.H. Linkwitz, "Active Crossover Networks for Noncoincident Drivers," *J. Audio Eng. Soc.*, vol. 24, pp. 2-8 (Jan/Feb 1976).
2. D. Bohn, "A Fourth-Order State-Variable Filter for Linkwitz-Riley Active Crossover Designs," presented at the 74th Convention of the Audio Engineering Society, New York, Oct. 9-12, 1983, preprint no. 2011.
3. D. Bohn, "Linkwitz-Riley Crossovers," *RaneNote*, (1983).
4. D. Bohn, "Why Not Wye?" *RaneNote*, (1984).
5. D. Bohn, "Linkwitz-Riley Active Crossovers Up To 8th-Order: An Overview," *RaneNote*, (1989).